

# *Easy Lift Equipment Co., Inc.*

2 Mill Park Court, Newark, Delaware 19713 - Phone: 800-233-1800 / 302-737-7000

## EASYLIFT DC POWERED EMPTY DRUM STACKER OPERATION & MAINTENANCE INSTRUCTIONS



## INTRODUCTION

EasyLift™ Empty Drum Stackers are designed for lifting, moving and triple stacking empty drums in trailers, eliminating the potential for injuries associated with manual handling and stacking. Empty drum stackers are DC powered and limited to a 100 lb./45.4 kg. capacity. The EG1 single clamping mechanism in these models has been modified to have lighter spring tension and provided with several adjustment positions for the clamping mechanism for positioning in the field as trailer heights and drum heights vary.

This manual contains information to acquaint you with the safe proper use and upkeep of the EL10072DC Empty Drum Stacker and should be available to personnel working with the unit. Before operating the unit, please read and understand the entire manual to be familiar with operations this equipment.

## IMPORTANT SAFETY INFORMATION

- 1. Be certain that the drum load weighs no more than the unit's maximum rated capacity of 100 lb./45.4 kg.**
- 2. Do not transport the drum at the maximum lifting height when moving the unit under load. The drum should be lowered when transporting so the drum is elevated only a few inches above floor level during transport.**
- 3. Keep hands and other objects clear of lifting chain, clamping head and mast during operation.**
- 4. Do not use the unit on inclined floors with a slope of more than 5 degrees. Consult your supervisor if you are unsure of this equipment.**
- 5. An inspection of the unit should be performed before using. Be certain that the Battery Compartment Door is locked, that the Clamping Head operational and that both chain anchors are securely in place before lifting.**
- 6. Never lay the unit down horizontally**
- 7. Never leave the machine unattended without applying the foot floor lock first, especially on an inclined floor. Doing so may cause the unit to roll by itself and cause property damage or personal injury.**
- 8. Exercise caution when triple stacking drums in trailers as it may be necessary to make adjustments to the lift height prior to use.**

## EASYLIFT™ EMPTY DRUM STACKER - DC POWERED OPERATING INSTRUCTIONS

This unit incorporates the use of an Eagle-Grip™ positive clamping mechanism. Clamping jaws will grab or release the drum automatically when raising or lowering the clamping head on a drum. The clamping mechanism is designed to handle a wide variety of rimmed drums with different heights. The clamping head is pin-mounted on the mast with several adjustment positions. The height of the clamping head can be adjusted by positioning in different adjustment holes based on the height of drums. Units shipped are shipped set to pick up 35” high standard 55-gallon drums. (See clamping mechanism image below)



1. Remove all packing materials, protective strapping and wood blocks used for shipping. Before using, open the plug on the hydraulic reservoir and install the breather cap. Then connect the negative battery cable to the negative side of the battery. Remove the keys located inside the cabinet and insert the key in the key switch located on the outside of the cabinet. Turn the key to the on position and the machine is ready for operation. Batteries are fully charged and ready for operation prior to shipping.
2. To lift a drum, push the unit toward the drum until the clamping head contacts firmly against the drum sidewall. Raise the clamping head by depressing the load up

portion of the rocker switch. The jaws will automatically grab the top chime when raising the clamping head.

3. To transport a drum, disengage floor locks first, if applicable. Adjust the height of the drum to approximately 2 or 3 inches above the floor. Then push or pull the unit to the desired location. To disengage the drum, depress the load down position of the rocker switch. Press the switch to lower until the drum comes to rest on the trailer floor or on top of another drum when stacking. The clamping jaws will retract automatically when the drum sits on the floor or a pallet. Simply pull the unit away to free it from the drum. **WARNING: Never hold down the rocker switch longer than required. It may cause the fuse to burn out.**
4. When stacking the drums three high in trailers for the first time, it may be necessary to reposition the clamping mechanism up or down to provide the necessary lift. **Extreme caution should be used to insure the clamping mechanism does not contact the roof of the trailer.**
5. To adjust the clamping head to a different adjustment hole, remove the round hang 2 circle cotter pin attached to a lanyard. Use one hand to hold the clamping head and use another hand to pull out the L-shaped adjusting pin. Slide the clamp up or down to the desired height and put pins back securely in place. There are 6 adjustment positions for placement of the clamping mechanism. The degree of forward tilt to the head is also adjustable. The machine is shipped with the clamping mechanism in a forward tilted position. This position is best for clamping drums, however the drum will be tilted slightly forward when lifted. Changing the degree of tilt to the clamping mechanism will keep the drum more vertical when lifted. To change the tilt to the clamp remove the other retaining pin attached to the other side of the lanyard. Remove the pin that travels thru the clamping mechanism. Push the clamping head back and reinsert the pin through the clamping mechanism. This pin will also need to pass through the upper jaw when being inserted. Then reinsert the retaining pin.
6. Additional adjustments for lift height can be made by the chain adjuster. The tighter the chain is adjusted the higher the machine will lift and vice versa. There are two ½"-13 nuts on the chain adjuster. **Warning: Be sure these nuts are tightened together before reusing the equipment.**
7. There are two adjustable flow control valves on this machine to regulate the lift and lower speeds. Both flow control valves are located at the base of the hydraulic cylinder behind the battery box. Turn either valve in a clockwise direction a little at a time until the desired speed is achieved. The upper valve controls the up or lift speed while the lower valve controls the down or decent speed.  
**Please note: If the upper valve is turned in too far, the hydraulic pump will whine due to the restricted oil flow. If the lower valve is turned too far, the mast will lower too slowly.**

## MAINTENANCE INSTRUCTIONS

1. Before every usage, check that all springs, pins, casters, lift chain and its anchors are in good working order and hydraulic cylinder works properly without leakage.  
**WARNING: Do not operate the unit if any part is missing or in poor condition, as this will directly affect the performance of the unit.**
2. On a monthly basis, spray light grade oil on moving parts in the clamping mechanism to ensure smooth operation. It is recommended to keep the clamping mechanism well oiled and free from foreign materials that may impede proper operation of jaws and springs. The DARCOR casters equipped on this unit have precision sealed ball bearing and require no lubrication. **WARNING: Do not leave the unit outside in the rain, snow, etc., for extended periods.**
3. For heavy usage of the unit, it is recommended to replace all springs, hydraulic oil and sealing components of the hydraulic cylinder be replaced once each year to ensure that the unit maintains a longer working life.
4. Check hydraulic fluid every 40 hours or before using the machine after long set-aside periods. Three quarts of fluid is sufficient to operate the system properly. Do not overfill. **Use AWG32 hydraulic fluid only.**
5. The EasyLift drum transporter uses (2) 12-volt deep cycle maintenance free AGM batteries wired in series (24 Volt system) which doesn't require periodic filling of water. **Only replace with 12-volt deep cycle maintenance free AGM batteries.**

## BATTERY CHARGING INSTRUCTIONS

All DC Powered Lift Drum Transporters are equipped with a 10 amp automatic on board battery charger. The charger will supply 5 amps to each battery for a total output of 10 amps. The charger is a "3-stage" electronic battery charger with two independent outputs. The charger is rainproof, lightweight, silent, automatic and will not boil off the electrolytes in acid batteries when left unattended.

1. Plug a grounded extension cord into built-in receptacles located on the side of the control cabinet. Plug the other end of the extension cord into a standard 115 volt/1/60 Hz AC outlet. Export models are equipped with a 220/1/50 outlet.
2. When the red LED is on, the charger is recharging the batteries at a rate of 10amps.
3. When both the red and green LED's are on, the charger is charging at an absorption rate between 3 and 9 amps. This mode of charging gradually "tops off" the batteries reducing harmful sulfating.
4. When the green LED is on, the charger is charging at a "float" or "maintenance" rate of less than 3amps. The batteries are now 90% charged and ready for use. The

“float” charging current will gradually decrease to as low as 0.1 amps as the batteries reach 100% charge. This keeps the batteries at full charge without overcharging. **Never operate the equipment when the battery charger is plugged into an AC outlet. This will burn out the circuit board in the battery charger.**

5. When re-charging is accomplished, unplug extension cord from Control Cabinet. The charger can be plugged in if the drum transport will not be used for long periods of time. The frequency of charging can only be determined by how often the unit is used.

### **CHARGING SAFETY PRECAUTIONS AND GENERAL NOTES:**

1. Generally, batteries will require equal charging to working time (example: one (1) hour of machine use = one (1) hour of re-charging time)
2. 12-Volt Deep Cycle batteries are required. The machine is provided with AGM deep cycle batteries, which do no gas when being recharged. Standard 12 Volt batteries are not designed to be drained and recharged a large number of times and if used will have a very short life.
3. To extend battery life, it is recommended that the batteries occasionally experience a full discharge. Doing this prevents the battery from developing a “memory” for a lesser charge
4. It is not recommended that alternate charger devices be used.
5. Someone should be within voice range or close enough to come to your aid when you work near lead acid batteries.
6. Have plenty of fresh water and soap nearby in case battery acid contacts skin, clothing or eyes. Avoid touching eyes while working near any battery.
7. Wear complete EE protection and clothing protection.
8. If acid contacts skin or clothing, wash immediately with soap and water. If acid enters the eye, flood the eye with cold, running water for at least 10 minutes and get medical attention.
9. Never smoke or allow open flame in the vicinity of the batteries.
10. Do not drop metal tools into the battery(s). It may spark, short circuit the battery, and cause an explosion.
11. Remove all personal metal items such as rings, bracelets, necklaces and watches when working near lead acid batteries. A battery can produce short circuit currents high enough to weld metal, causing severe burn.
12. Do not charge batteries if cables or LED’s are damaged. Always keep battery terminals clean and free of corrosion. Never change a frozen battery.

**CHARGER WARRANTY:** This charger is warranted to be free of defects in materials and workmanship for a period of 2 years from date of purchase.

# EASY LIFT DC POWERED EMPTY DRUM STACKER

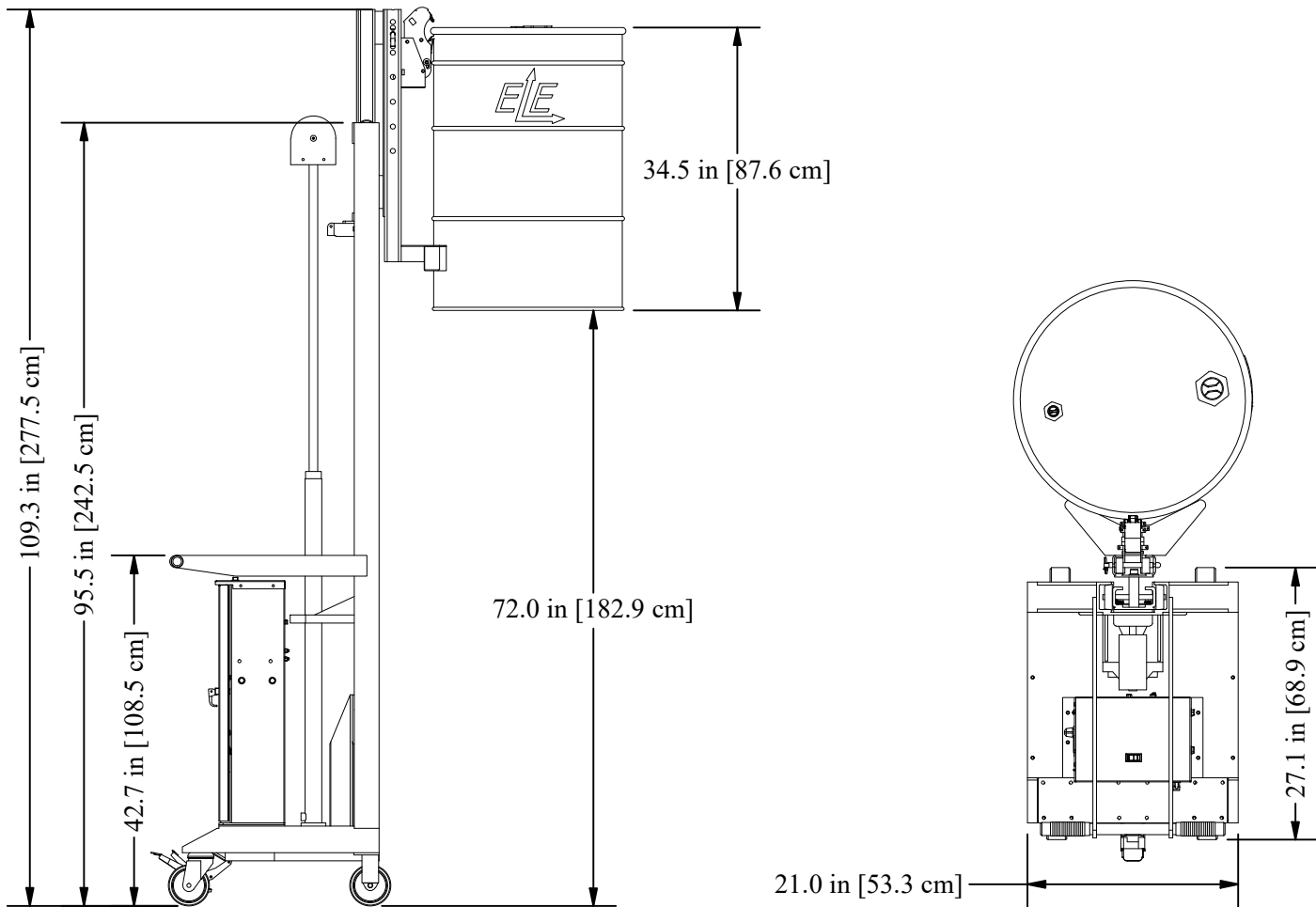
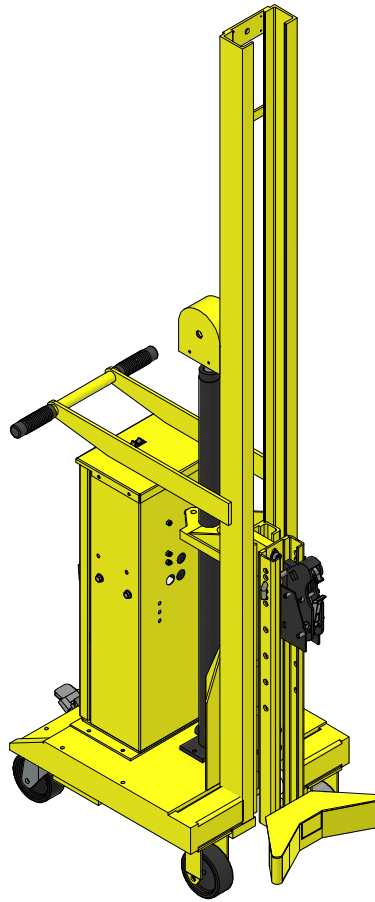

# **Easy Lift Equipment Co., Inc.**

**2 Mill Park Court, Newark, Delaware 19713 - Phone: 800-233-1800 / 302-737-7000**

## **Operator's Daily Checklist**

### **Drum Transporter (DC Powered) with Eagle-Grip® Clamp, V-Pan or Roll Post**

Inspections Performed by: \_\_\_\_\_

Note: This inspection must be made by the equipment operator **daily** at the start of the shift. Check (✓) the appropriate "OK" or "Needs Repair" field.

This Daily Checklist is intended to help verify that the equipment is in proper working order each day.

**More thorough Weekly, Monthly and Yearly Maintenance schedules should still be followed.**

VISUAL CHECK		DATE: _____ / _____ / _____ / _____ / _____ / _____ / _____ / _____ / _____ / _____ / _____ / _____ / _____ / _____ / _____ / _____													
		OK	Needs Repair	OK	Needs Repair	OK	Needs Repair	OK	Needs Repair	OK	Needs Repair	OK	Needs Repair	OK	Needs Repair
<b>VISUAL CHECK: FRAME &amp; MAST</b>	<b>DATA PLATES &amp; WARNING DECALS</b> - Data Plates & Warning Decals are affixed to the unit and in good condition														
	<b>DAMAGE</b> - Look for bent, dented or broken parts. This includes hydraulic lines, electrical wires, frame welds, wheels, & bolted connections														
	<b>LIFT CHAIN</b> - Visually ensure lift chain is connected and not loose														
	<b>LIFT CYLINDER</b> - Ensure that the hydraulic lift cylinder and all lines are in operable condition														
	<b>DC BOX</b> - Ensure that the DC Box, as well as all controls, are in good condition with no visual damage														
	<b>BATTERY &amp; FUSES</b> - Open the DC Box and visually ensure the battery cables & connections are in good condition & secure. Ensure DC cable fuses are intact														
	<b>LEAKS</b> - Check for any leaking oil, hydraulic fluid or battery acid														
	<b>GUARDS</b> - Verify that all chain guards are in place and in proper condition														
<b>VISUAL CHECK: EAGLE CLAMP</b>	<b>CLAMP DAMAGE</b> - Look for bent, dented or broken clamp components. This includes the clamp housing, the upper and lower clamping jaws, retaining pins, cotter pins, and springs														
	<b>CLAMP PINS</b> - Confirm that all retaining pins and cotter pins are accounted for and secure														
<b>VISUAL CHECK: V-PAN OR ROLL POST</b>	<b>V-PAN/ROLL POST DAMAGE</b> - Look for bent, dented or broken components. This includes all welds and bolted connections of both the V-Pan assembly and the Roll Post and mounting receiver, including all applicable safety pins, retaining pins, latching pins and cotter pins														
	<b>V-PAN/ROLL POST PINS</b> - Confirm that all applicable safety pins, retaining pins and cotter pins are accounted for and secure														
<b>VISUAL: SCALE</b>	<b>SCALE SYSTEM &amp; PRINTER</b> - If applicable, confirm that the scale and printer as well as all wires, and cables are in good condition and properly connected														

**Checklist Continued on Next Page**

# Easy Lift Equipment Co., Inc.

2 Mill Park Court, Newark, Delaware 19713 - Phone: 800-233-1800 / 302-737-7000

## Operator's Daily Checklist (cont.)

### Drum Transporter (DC Powered) with Eagle-Grip® Clamp, V-Pan or Roll Post

OPERATIONAL CHECK		DATE: / / / / / / / / / / / / / / / /													
		OK	Needs Repair	OK	Needs Repair	OK	Needs Repair	OK	Needs Repair	OK	Needs Repair	OK	Needs Repair	OK	Needs Repair
OPERATIONAL CHECK: FRAME & MAST	<b>POWER UP</b> - Turn on the Master Disconnect Switch on the DC Box. Ensure Power is supplied to the unit and the Battery Discharge Indicator lights are in proper working order														
	<b>FOOT FLOOR LOCK</b> - Verify that the Foot Floor Lock engages and disengages properly														
	<b>WHEELS AND TRAVEL</b> - Confirm that the unit travels properly. Ensure that the wheels are aligned properly, unobstructed, and not damaged														
	<b>CONTROLS</b> - Verify that both the lift and lower functions on the top of the DC Box are in proper working order														
	<b>MAST</b> - Ensure the clamping head, V-Pan or Roll Post moves smoothly up and down the mast, with no obstruction or unusual noises														
EAGLE-GRIP	<b>EAGLE-GRIP CLAMPING HEAD</b> - Verify that the Eagle-Grip Clamping Head engages and disengages a drum properly. Only lift the "test" drum to the minimum height required while completing this test														
V-PAN OR ROLL POST	<b>V-PAN/ROLL POST FUNCTION</b> - Verify proper function of all V-Pan or Roll Post components, including smooth rotation of the Stainless Steel V-Pan tray (if applicable), as well as proper operation of Roll Post rollers and/or folding capabilities (if applicable)														
SCALE & PRINTER	<b>SCALE SYSTEM &amp; PRINTERS</b> - If applicable, power up the scale and printer. Ensure the scale and printer are in proper working order														

List the details of all required repairs in the comments section below. Then, **tag and decommission the equipment for safety.**

**Comments (items needing repair or adjustment):** \_\_\_\_\_

\_\_\_\_\_

\_\_\_\_\_

\_\_\_\_\_

\_\_\_\_\_

\_\_\_\_\_

**Caution** – If the equipment is found to be in need of repair or in any way unsafe, or contributes to an unsafe condition, the matter shall be reported immediately to the designated supervisor, and the equipment shall not be operated until it has been restored to a safe operating condition. If during operation, the equipment becomes unsafe in any way, the matter shall be reported immediately to the designated supervisor, and the equipment shall not be operated until it has been restored to safe operating condition. Do not make repairs or adjustments unless specifically authorized to do so.

# Easy Lift Equipment Co., Inc.

2 Mill Park Court, Newark, Delaware 19713 - Phone: 800-233-1800 / 302-737-7000

## EASY LIFT EQUIPMENT WARRANTY POLICY FOR MODELS WITH PREFIXES: ED/ER/EL/ELDR/EG & RCR

**Easy Lift Equipment (“ELE”)** warrants each new product to be free from factory material and workmanship defects, under normal use with proper maintenance, for a period of 12 months. Warranty coverage for this warranty period is provided by authorized dealers and includes parts. Labor is covered for the same periods of 12 months as outlined above. Please call ELE for the authorized repair dealer in your area.

ELE shall be the sole judge of the validity of any claim or defect and may elect to make any replacement or repair of any part thereof that it has agreed to be defective. Wearable Items such as: hoses, bearings, belts, brushes, seals, lift motors, clamp motors, relays, fuses, springs and wheels are wear items not covered under the warranty policy. ELE assumes no responsibility whatsoever to work done, parts replaced, or expenses incurred not specifically authorized by ELE. Normal maintenance or replacement of service items is not covered by this warranty. No warranty claims will be considered for customers with any delinquent outstanding balance. When batteries, battery chargers, scale printers or scale indicators are purchased from ELE with the equipment, the original manufacturer’s warranty applies.

### **WARRANTY LIMITATION/DISCLAIMERS:**

Easy Lift Equipment reserves the right to void warranty coverage if the unit has been overloaded beyond rated capacity; damaged due to: abuse, misuse, neglect, accidents, freight damage, improper usage, improper repair, and/or improper storage; or any modification or repair conducted in a manner not approved by Easy Lift Equipment. Equipment used in freezers, abrasive, corrosive, and/or excessively moist conditions must be properly equipped for the environment to ensure the warranty is not voided. Warranty questions and claims should be directed to our customer service department. ELE customer service representatives will help you assess and resolve the claim or assist you in contacting the local authorized dealer or representative. The warranty described here shall constitute the sole remedy of the authorized dealer and/or the initial purchaser. ELE neither assumes nor authorizes any person to assume for it any other obligation or responsibility in connection with this product warranty. In no event shall ELE be responsible for direct, indirect, special or consequential damages or any other delay or any economic or commercial loss resulting from Easy Lift Equipment’s performance or non-performance under this warranty. This warranty is expressly in lieu of all warranties, obligations or responsibilities of ELE dealers or other authorized source, expressed, implied or statutory.

### **SUBMITTING CLAIMS:**

To make a claim under this policy, please contact Easy Lift Equipment for assistance. We can be reached by calling 800-233-1800 ext. 4 for customer service or by writing to [sales@easylifteqpt.com](mailto:sales@easylifteqpt.com). Do not return defective parts unless a return authorization (RA) has been provided requesting the return. If requested, we will provide shipping information on how the part should be returned and bear the expense for the return shipping, if the part is proven to be defective. A copy of the work order made at the time of the repair and parts claimed under warranty may be requested for ELE’s inspection.

### **ORDERING PARTS:**

Easy Lift Equipment’s parts are distributed through our customer service department and ship the same day as ordered whenever possible. You will be well taken care of whenever parts, adjustments or repairs are needed. **When contacting ELE, please be sure to state the model and serial number for the equipment.** There is no cost for electronic copies of replacement manuals, parts lists and other general information containing part numbers and nomenclature. Most manuals contain parts pricing, but it is not guaranteed to be valid as parts pricing can change at any time without notice. Any customer service representative can provide timely parts quotations upon request. Adherence to above procedure will save time and provide prompt assistance when it counts. You are of course always welcome to bring to us any questions, comments or recommendations pertaining to your Easy Lift Equipment products.

### **MANUFACTURER CONTACT INFORMATION:**

Easy Lift Equipment Co., Inc.  
2 Mill Park Ct.  
Newark, DE 19713  
Email: [sales@easylifteqpt.com](mailto:sales@easylifteqpt.com)

Phone: 800-233-1800: 302-737-7000  
Fax: 302-737-7333  
Website: [www.easylifteqpt.com](http://www.easylifteqpt.com)

# OPERATION



## Display

- 1** Only when the battery is properly charged is the right-most LED lit.
- 2** As the battery's state-of-charge decreases, successive LEDs light up, only one on at a time.
- 3** The 2nd-from-left LED flashes, indicating "energy reserve" (70% depth of discharge).
- 4** The 2 left-most LEDs alternately flash, indicating "empty" (80% depth of discharge).

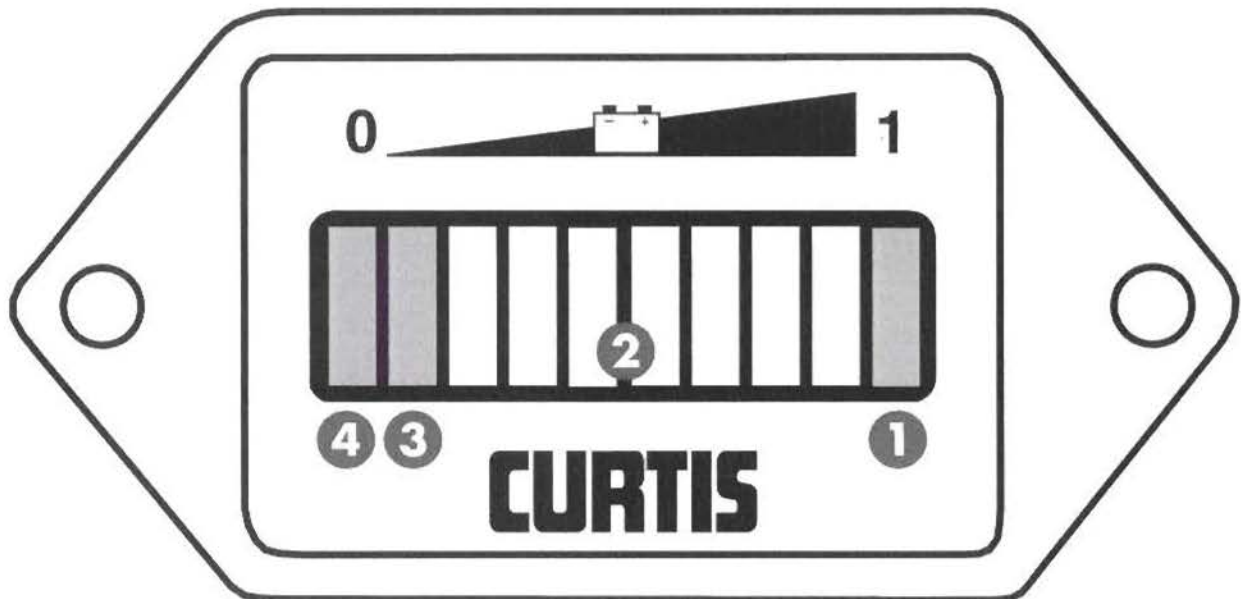

# EMPTY DRUM STACKER FRAME ASSEMBLY

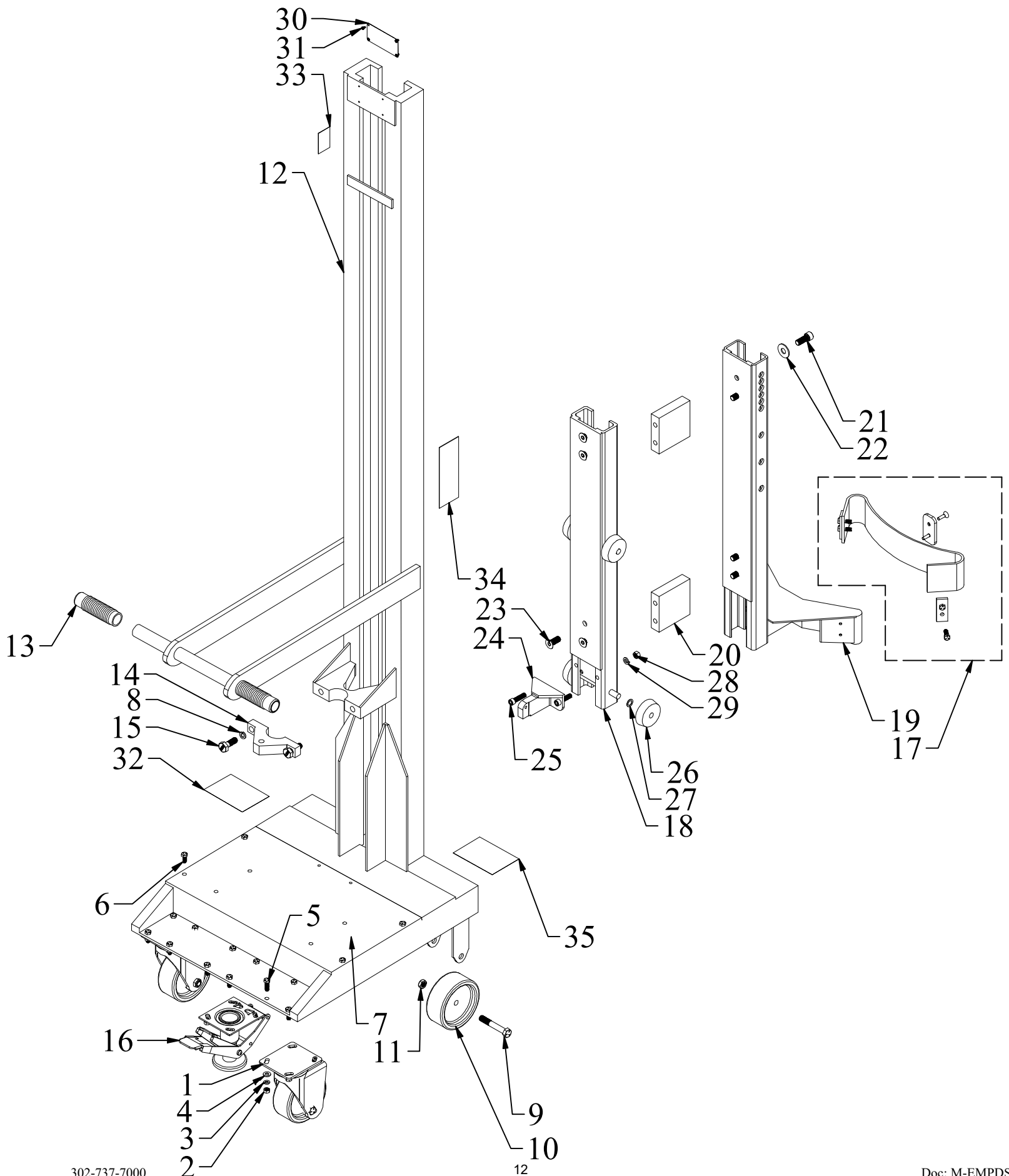

## EMPTY DRUM STACKER FRAME PARTS LIST

<u>ITEM</u>	<u>PART NO.</u>	<u>DESCRIPTION</u>	<u>QTY</u>
1	31-405-PD	5" Swivel Caster with PD Wheel	2
-	W-405-PD	5" PD Wheel Only	-
2	5/16-18 HN	5/16-18 Finished Hex Nut (zinc)	12
2	5/16-18 HN-SS	5/16-18 Finished Hex Nut (stainless steel)	12
3	5/16 LW	5/16 Lock Washer (zinc)	12
3	5/16 LW-SS	5/16 Lock Washer (stainless steel)	12
4	5/16 FW	5/16 Flat Washer (zinc)	12
4	5/16 FW-SS	5/16 Flat Washer (stainless steel)	12
5	5/16-18 x 1 HHCS	5/16-18 x 1 Hex Head Cap Screw Grade 5 (zinc)	12
5	5/16-18 x 1 HHCS-SS	5/16-18 x 1 Hex Head Cap Screw (stainless steel)	12
6	5/16-18 X 3/4 HHCS	5/16-18 x 3/4 Hex Head Cap Screw Grade 5 (zinc)	4
6	5/16-18 X 3/4 HHCS-SS	5/16-18 x 3/4 Hex Head Cap Screw (stainless steel)	4
7	2580305	SL Ergo Top Plate (DC Style)	1
8	1/2 LW	1/2 Lock Washer (zinc)	2
9	1/2-20 x 3 1/4 HHCS	1/2-20 x 3 1/4 Hex Head Cap Screw (zinc)	2
10	31-405R-PD	5" Rigid Caster with PD Wheel	2
-	W-405-PD	5" PD Wheel Only	-
11	1/2-20 THIN NLN	1/2-20 Thin Nylon Locking Nut (Zinc)	2
12	3530128	Empty Drum Stacker Frame	1
13	65657	Handle Grips	2
14	35091	Cylinder Clamp Bracket	1
15	1/2-13 x 1 1/2 HHCS	1/2-13 x 1 1/2 Hex Head Cap Screw Grade 5 (zinc)	2
15	1/2-13 x 1 1/2 HHCS-SS	1/2-13 x 1 1/2 Hex Head Cap Screw (stainless steel)	2
16	16LF0580	Step Down Floor Lock (for 5" wheels)	1
17	5516E	Optional: Belt Cradle Kit (3" wide x 23" long, includes all hardware)	1
18	3534401	Inner Mast - Empty Drum Stacker	1
19	3534453	Outer Mast - Empty Drum Stacker	1
20	LCRB	Load Cell Replacement Block	2
21	1/2-20 x 1 1/4 SHCS	1/2-20 x 1 1/4 Socket Head Cap Screw Alloy Plated	4
22	1/2 FW	1/2 Flat Washer (zinc)	4
22	1/2 FW-SS	1/2 Flat Washer (stainless steel)	4
23	1/2-20 x 1 1/4 FSHCS	1/2-20 x 1 1/4 Flat Socket Head Cap Screw (zinc)	4
24	8912HR-EDS	High Reach Chain to Mast Bracket for Empty Drum Stacker	1
25	3/8-16 x 1 1/2 SHCS	3/8-16 x 1 1/2 Socket Head Cap Screw Alloy Plated	2
25	3/8-16 x 1 1/2 SHCS-SS	3/8-16 x 1 1/2 Socket Head Cap Screw (stainless steel)	2
26	4008	Delrin Roller	4
27	90295A187	1/16" Nylon Flat Washer	-
27	95606A170	1/32" Nylon Flat Washer	-
28	3/8-16 HN	3/8-16 Finished Hex Nut (zinc)	2
28	3/8-16 HN-SS	3/8-16 Finished Hex Nut (stainless steel)	2
29	3/8 LW	3/8 Lock Washer (zinc)	2
29	3/8 LW-SS	3/8 Lock Washer (stainless steel)	2
30	MCL007031	Specification Plate	1
31	6 x 1/4 RUDS-SS	6 x 1/4 Round Head U Drive Screw (stainless steel)	4
32	ADART002	Attention Read Operations Manual Decal	1
33	ADART009	Warning 5 Degree Decal for ELE & EL	1
34	ADART016	ELE Address Decal (Vertical)	2
35	ADART100	100lbs/45kg Capacity Sticker	1

# DRUM TRANSPORTER LIFT CHAIN ASSEMBLY

DOUBLE FLOW CONTROL  
VALVES

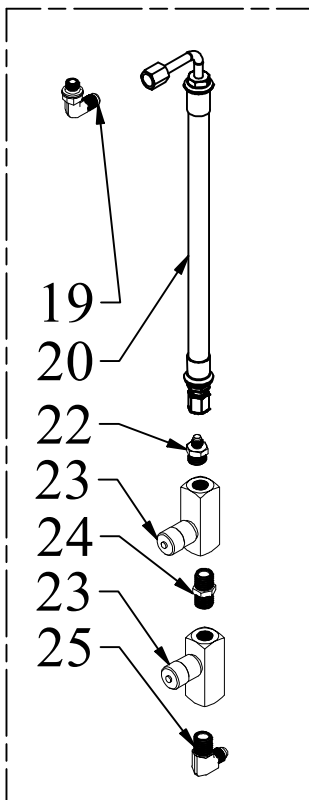

SINGLE FLOW CONTROL  
VALVE

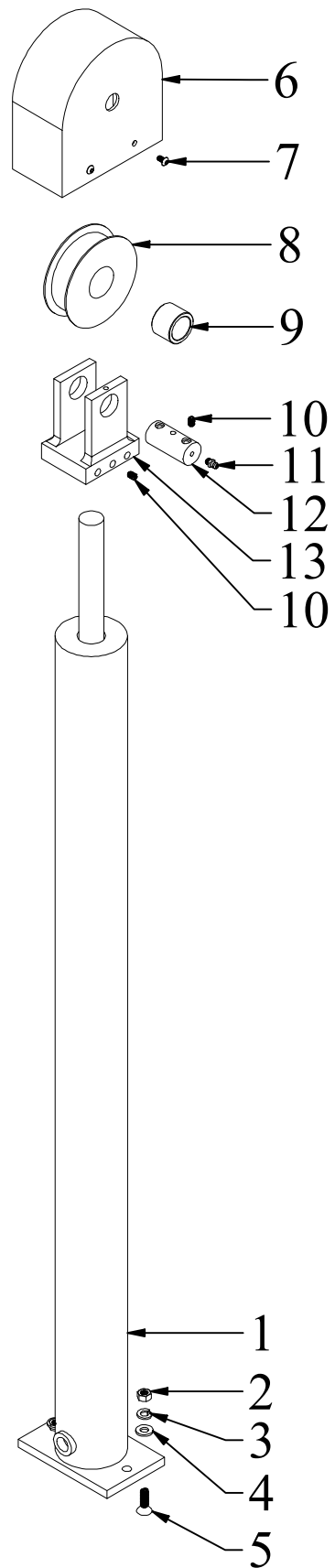
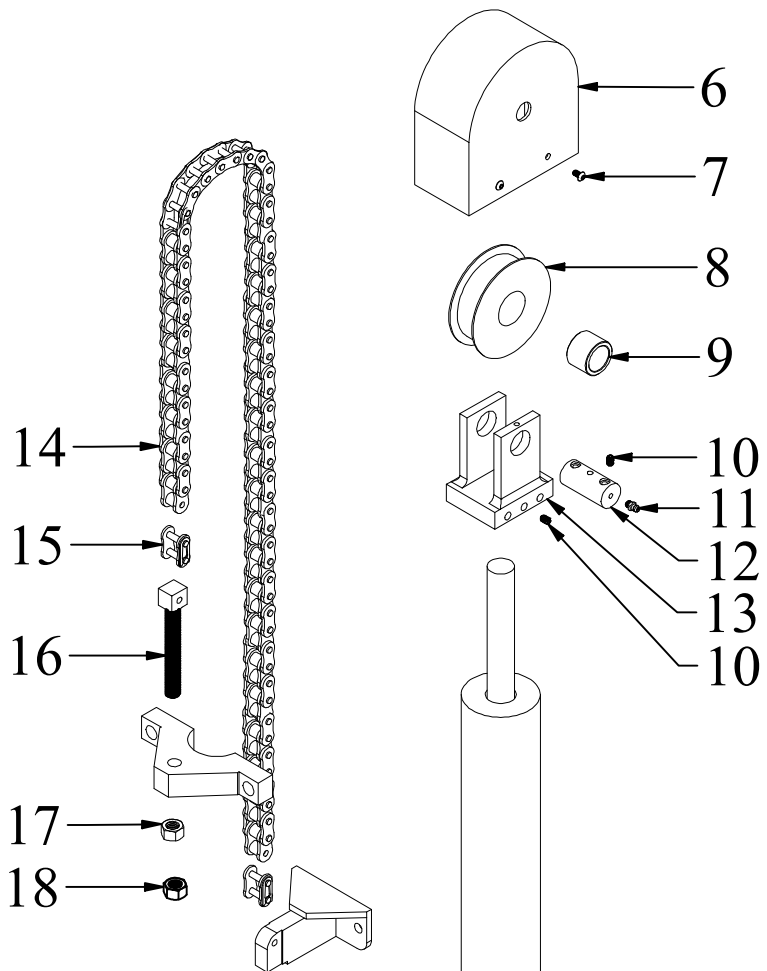
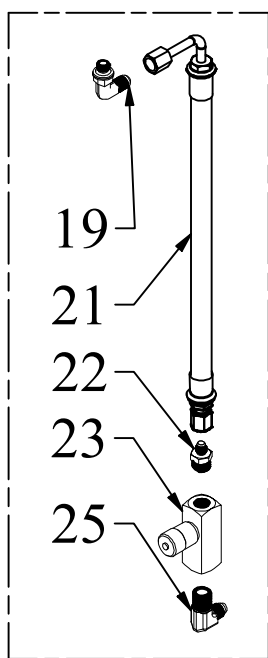

## DRUM TRANSPORTER LIFT CHAIN PARTS LIST

<u>ITEM</u>	<u>PART NO.</u>	<u>DESCRIPTION</u>	<u>QTY</u>
1	EL1.5-1.0-24BZ	Hydraulic Lift Cylinder	1
1	EL1.5-1.0-28BZ	Hydraulic Lift Cylinder	1
1	EL1.5-1.0-32BZ	Hydraulic Lift Cylinder	1
1	EL1.5-1.0-36BZ	Hydraulic Lift Cylinder	1
1	EL1.5-1.0-40BZ	Hydraulic Lift Cylinder	1
-	EL1.5PISTONKIT	Seal Kit (new piston, seals & wire)	-
2	5/16-18 HN	5/16-18 Finished Hex Nut (zinc)	2
2	5/16-18 HN-SS	5/16-18 Finished Hex Nut (stainless steel)	2
3	5/16 LW	5/16 Lock Washer (zinc)	2
3	5/16 LW-SS	5/16 Lock Washer (stainless steel)	2
4	5/16 FW	5/16 Flat Washer (zinc)	2
4	5/16 FW-SS	5/16 Flat Washer (stainless steel)	2
5	5/16-18 x 1 1/4 FSHCS-SS	5/16-18 x 1 1/4 Flat Socket Head Cap Screw (stainless steel)	2
6	3022	4" Sheave Wheel Cover	1
7	10-24 x 3/8 BSC-SS	10-24 x 3/8 Button Socket Cap 18/8 (stainless steel)	4
8	55061	4" Sheave Wheel	1
9	CB-1622-08	Sheave Wheel Bushing	1
10	93445A425	1/4"-20 x 3/8" Stainless Steel Knurl-Grip Set Screw	2
11	1095K41	1/4"-28 Grease Fitting	1
12	45061	Sheave Wheel Axle (1" x 2.125")	1
13	7912-4-1	Sheave Wheel Bracket 4" (1" bore)	1
14	RC060RC1-49	Chain-Ansi 60 (49" Long)	1
14	RC060RC1-49PC	FDA Chain-Ansi 60 (49" Long)	1
14	RC060RC1-65	Chain-Ansi 60 for Ergo (65" Long)	1
14	RC060RC1-65PC	FDA Chain-Ansi 60 for Ergo (65" Long)	1
14	RC060RC1-73	Chain-Ansi 60 for Ergo (73" Long)	1
14	RC060RC1-73PC	FDA Chain-Ansi 60 for Ergo (73" Long)	1
15	60HMCL	ANSI 60 Link	2
15	ARC060SCL1	FDA ANSI 60 Link	2
16	2022	Chain Adjuster for ANSI 60 Chain	1
17	1/2-13 HN	1/2-13 Finished Hex Nut (zinc)	1
17	1/2-13 HN-SS	1/2-13 Finished Hex Nut (stainless steel)	1
18	1/2-13 NLN	1/2-13 Nylon Locking Nut (zinc)	1
18	1/2-13 NLN-SS	1/2-13 Nylon Locking Nut (Stainless Steel)	1
19	6C4OMXS	* HPI 90 Deg Fitting (Post 2013)	1
19	6-6 C4OMXS	** 90 Male Elbow 3/8 BSPP	1
20	487TC-6-F-I-7.5	7.5" long 3/8" Hydraulic Hose w/ (1) Fml Swvl St. & (1) Fml 90° Long Drop Elbow	1
21	487TC-6-F-I-10.5	10.5" long 3/8" Hydraulic Hose w/ (1) Fml Swvl St. & (1) Fml 90° Long Drop Elbow	1
22	6-6 FTX-S	Male Connector	1
23	F600B	Flow Control 3/8" NPT	2 / 1
24	PA80702	Hex Nipple	1
25	PA80806	90 Male Elbow 3/8T 3/8PT	1

\* Fitting for HPI Pump

\*\* Fitting for Rexroth Pump

# LIFT ONLY DC CABINET WITH REXROTH PUMP & MASTER DISCONNECT HARDWARE ASSEMBLY

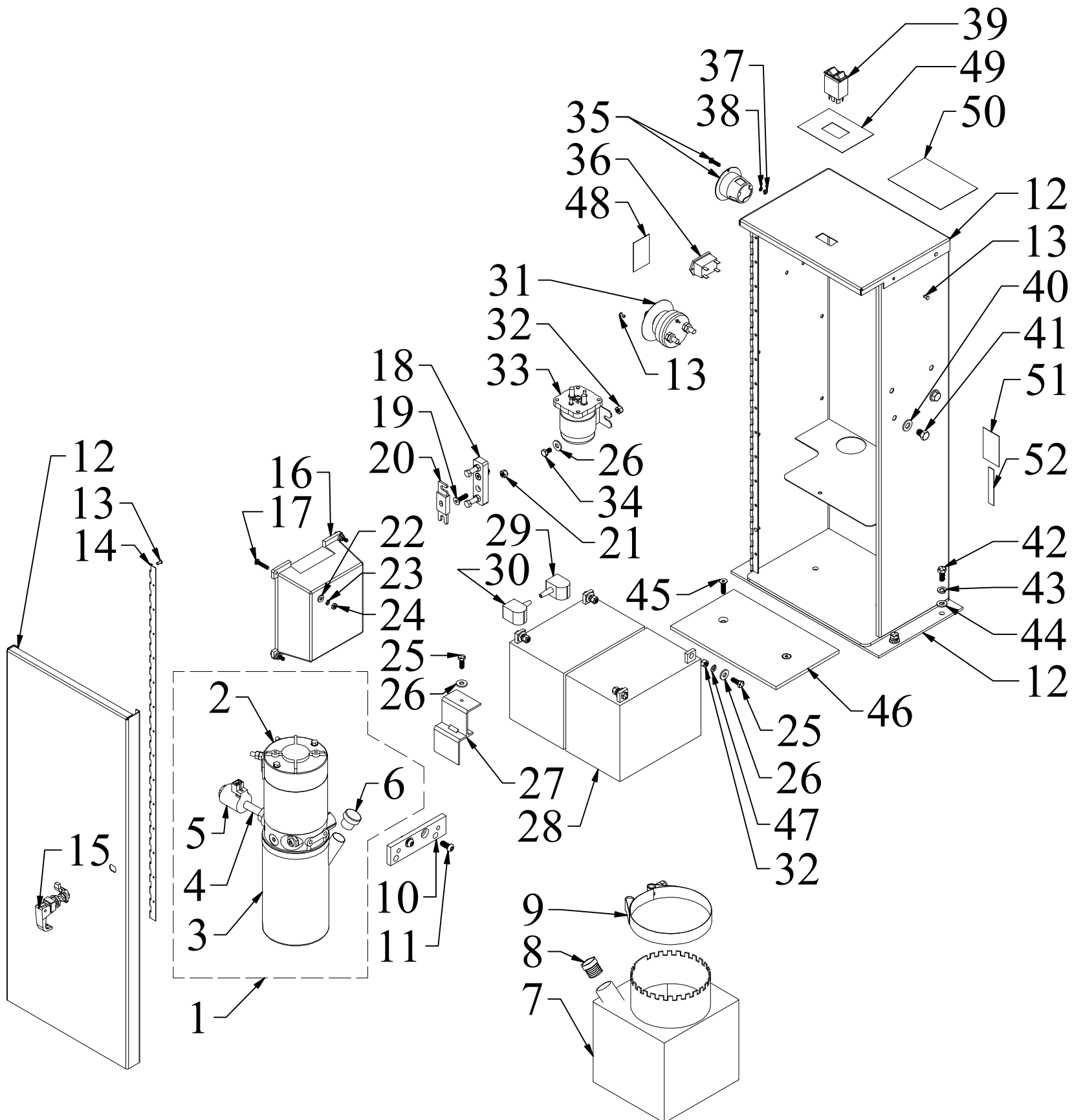

**LIFT ONLY DC CABINET WITH REXROTH PUMP  
& MASTER DISCONNECT HARDWARE  
PARTS LIST**

<u>ITEM</u>	<u>PART NO.</u>	<u>DESCRIPTION</u>	<u>QTY</u>
1	ELE51495653	Rexroth - Hydraulic Assy. with Elbow (Gen 1, DH s/n: C23051 to Present, EL Gen 4)	1
2	51637048	Pump Motor	1
3	51637055	Hydraulic Tank	1
4	51637057	Solenoid Valve	1
5	51599237	Magnetic Coil	1
6	51057393	Breather & Dip Stick	1
7	# DM106	Rexroth XL Hydraulic Tank	1
8	# 9833K11	1/2" Breather Vent	1
9	# 5204K16	Rexroth pump metal bolt clamp (4-9/32" to 4-19/32")	1
10	MM10001	2022 DC Box Pump Mounting bracket	1
11	M8-1.25 X 20MM BSHCS-A	M8-1.25 x 20mm Button Socket Head Cap Screw Alloy	2
12	3530233	EL or SL DC Cabinet w/ Welded Plate & 1 Hole Lid and Door	1
12	* DM021-2025	DC Cabinet 29 5/8" Tall w/o Welded Plate with 1 Hole Lid and Door	1
-	DM099	DC Cabinet Door	1
-	DM091	DC Cabinet One Hole Lid	1
13	97447A025	Aluminum Blind Rivet 1/8" for material .188-.25"	19
14	CS24010628H	Cabinet Hinge	1
15	S 62-10-23	Lift & Turn Latch	1
16	IS2	12 amp 2 bank 110/220/50-60/1ph CE Charger	1
-	7821055	AGC 30A Fuse (5 pack)	1
17	10-24 x 1 PMS-SS	10-24 x 1 Phillips Machine Screw (stainless steel)	4
18	4164	Limiter Fuse Block	1
19	1/4-20 x 1 FSHCS-SS	1/4-20 x 1 Flat Socket Head Cap Screw (stainless steel)	2
20	ANL-250	Fuse, 250A, Series ANL, 32VAC/80VDC	1
21	102672611	1/4-20 SS Acorn Nut	2
22	10 FW-SS	#10 Flat Washer 18/8 (stainless steel)	4
23	10 LW-SS	#10 Lock Washer 18/8 (stainless steel)	4
24	10-24 HN-SS	10-24 Finished Hex Nut 18/8 (stainless steel)	4
25	1/4-20 x 3/4 HHCS	1/4-20 x 3/4 Hex Head Cap Screw Grade 5 (zinc)	5
25	1/4-20 x 3/4 HHCS-SS	1/4-20 x 3/4 Hex Head Cap Screw (stainless steel)	5
26	1/4 FW SAE	1/4 Flat Washer SAE (zinc)	7
26	1/4 FW-SS	1/4 Flat Washer (stainless steel)	7
27	2580045	Battery Bracket	1
28	DCM0035L	12v DC 35Ah Deep Cycle Battery (List Price \$ 140.00, Limited time promo price)	2
29	DEK06119	Right Elbow Boot 4-8 GA Red	2
30	DEK06120	Left Elbow Boot 4-8 GA Black	2
31	PA16529	Master Disconnect Switch	1
32	1/4-20 NLN	1/4-20 Nylon Locking Nut (zinc)	6
32	1/4-20 NLN-SS	1/4-20 Nylon Locking Nut (stainless steel)	6
33	% 586-114111	Motor Solenoid 24 volt/200 amp Continuous Duty	1
34	1/4-20 x 1/2 HHCS-SS	1/4-20 x 1/2 Hex Head Cap Screw (stainless steel)	2
35	HBL5278C	120 volt A/C Receptacle (Male)	1
35	HBL5678C	220 volt A/C Receptacle (Male)	1
36	T101772	24 Volt Battery Discharge Indicator (906T24JWDGN)	1
37	9079	18-8 SST Hex Mach Screw Nuts 6-32	2
38	9098	18-8 SST Lock Washers Size #6	2
39	8555K32X32M	White Rocker Switch	1
40	3/8 LW-SS	3/8 Lock Washer (stainless steel)	2
41	3/8-16 x 1 HHCS-SS	3/8-16 x 1 Hex Head Cap Screw (stainless steel)	2
42	5/16-18 X 3/4 HHCS	5/16-18 x 3/4 Hex Head Cap Screw Grade 5 (zinc)	4
42	5/16-18 X 3/4 HHCS-SS	5/16-18 x 3/4 Hex Head Cap Screw (stainless steel)	4
43	5/16 LW	5/16 Lock Washer (zinc)	4
43	5/16 LW-SS	5/16 Lock Washer (stainless steel)	4
44	5/16 FW SAE	5/16 Flat Washer SAE (zinc)	4
44	5/16 FW SAE-SS	5/16 Flat Washer SAE (stainless steel)	4
45	* 1/4-20 x 1 FSHCS-SS	1/4-20 x 1 Flat Socket Head Cap Screw (stainless steel)	2
46	* 3530234	DC Cabinet Inner Mounting Plate (CB, ELDR, ED, ER)	1
47	1/4 LW	1/4 Lock Washer (zinc)	4
	<u>DECAL</u>	<u>DESCRIPTION</u>	
48	ADART025	120 Volts AC Warning Decal	1
48	ADART043	220 Volts AC Warning Decal	1
49	ADART007	Decal "Lift"	1
50	ADART028	Attention Operating Equipment While Charging Will Damage Decal	1
51	ADART042	"Attention Read Operations Manual Before Adjusting" Decal	1
52	ADART021	Flow Control Decal "UP/DOWN"	1
	<u>HYDRAULIC FLUID</u>	<u>DESCRIPTION</u>	
	AWG32	Hydraulic Oil AWG32	1
	FG32/46	Food Grade 32/46 Hydraulic Synthetic Lubricant	1

# First used on A25032

\* For Counterbalance Models Only

% New style Solenoid first used on E25015 (if sold as replacement for old style Solenoid, kit 3530550 or 3530552 will be required).

# LIFT ONLY DC CABINET WITH REXROTH PUMP & MASTER DISCONNECT WIRING ASSEMBLY

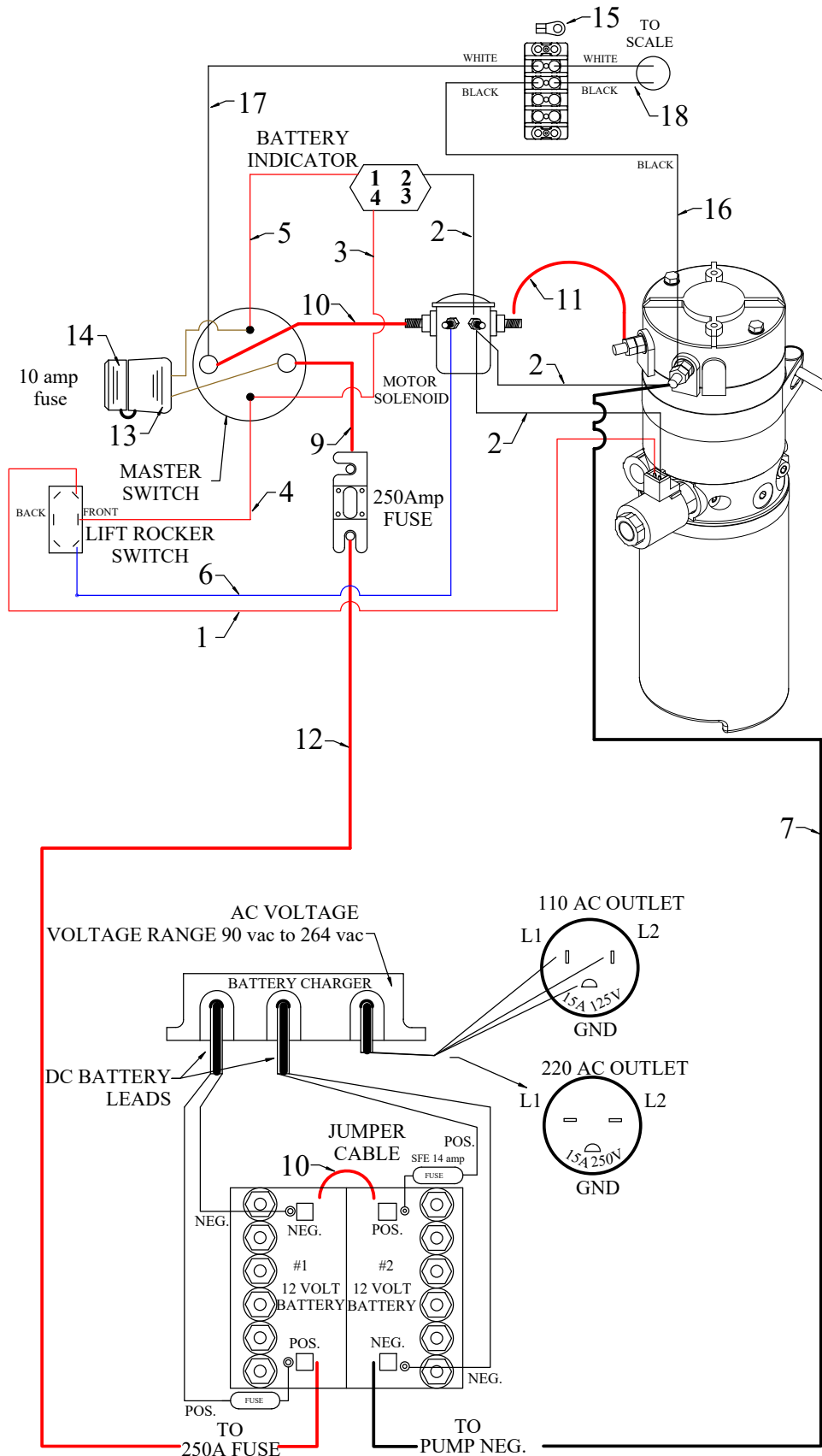

**LIFT ONLY DC CABINET WITH REXROTH PUMP  
& MASTER DISCONNECT WIRING  
PARTS LIST**

<u>ITEM</u>	<u>PART NO.</u>	<u>DESCRIPTION</u>	<u>QTY</u>
1	80094UZ-29-9	9" Signal Wire with (1) 16-14 .250 end	1
2	80097UZx3-29-84-80-06	(3) Lengths of Black Wire w/ PA80029, PA85884, PA85880 & PA80206 ends	1
3	80094UZ-06-29-6	6" Signal Wire with (1) .250 & (1) #10 end	1
4	80094UZ-06-29-8	8" Signal Wire with (1) .250 & (1) #10 end	1
5	80094UZ-06-29-5	5" Signal Wire with (1) .250 & (1) #10 end	1
6	80098UZ-06-29-6	6" Blue Signal Wire with (1) .250 & (1) #10 end	1
7	113765-67-67-22.5	BLACK Battery Cable 22.5" - 4ga with (2) 5/16" Ring Terminal Ends	1
8	113766-67-67-12	RED Battery Cable 12" - 4ga with (2) 5/16" Ring Terminal Ends	1
9	113766-67-68-9	RED Battery Cable 9" - 4ga (1) 5/16" and (1) 3/8" Ring Terminal Ends	1
10	113766-67-68-6.5	RED Battery Cable 6.5" - 4ga with (1) 5/16" and (1) 3/8" Ring Terminal Ends	1
11	113766-67-67-9	RED Battery Cable 9" - 4ga with (2) 5/16" Ring Terminal Ends	1
12	113766-67-67-24	RED Battery Cable 24" - 4ga with (2) 5/16" Ring Terminal Ends	1
13	210954-94-06	In Line Fuse Holder with (1) #3/8 and (1) #10 ends	1
14	PA82693	Auto Fuse, ATC Type, Red, 10A	1
	<b><u>SCALE WIRING OPTION</u></b>	<b><u>DESCRIPTION</u></b>	
15	PA80206	NYLON RING TERM 16-14 GA #10, BLU	4
16	80097UZ-84-06-15	15" Black wire with (1) PA85884 & (1) PA80206 ends	1
17	80095-94-06-20	20" White wire with (1) PA80194 & (1) PA80206 ends	1
18	PA12686-36	36" Length of 14 GA 2 Conductor Auto Duplex Wire	1

# REXROTH HYDRAULIC PUMP 51495653 (GEN. 1 / ELE GEN. 4) JULY 2019 TO PRESENT ASSEMBLY

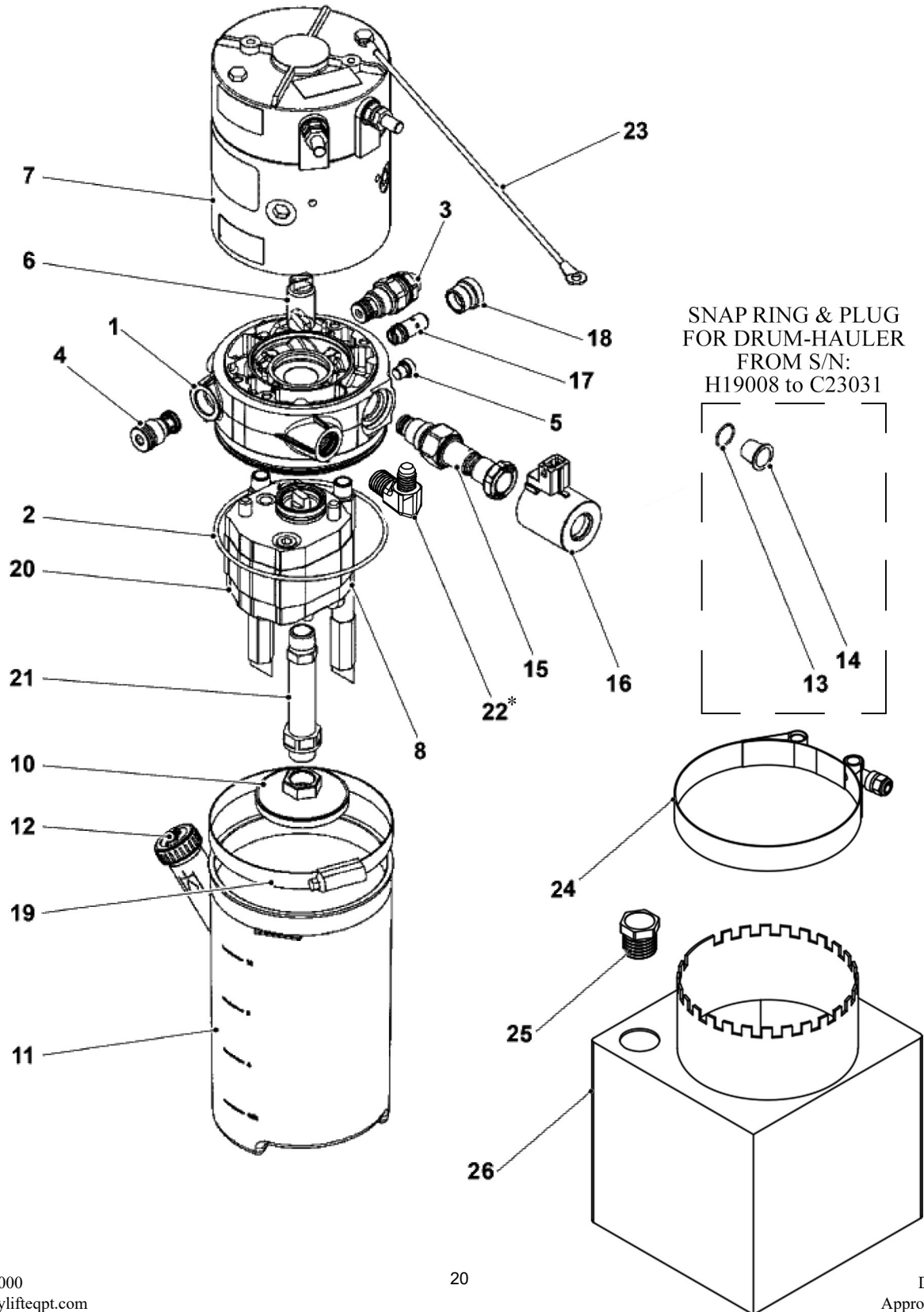

**REXROTH HYDRAULIC PUMP  
51495653 (GEN. 1 / ELE GEN. 4) JULY 2019 TO PRESENT  
PARTS LIST**

<u>ITEM</u>	<u>PART NO.</u>	<u>DESCRIPTION</u>	<u>QTY</u>
	51495653	Rexroth - Hydraulic Assy. (Gen 1, DH s/n: H19008 to C23031)	
	ELE51495653	Rexroth - Hydraulic Assy. with Elbow (Gen 1, DH s/n: C23051 to Present, EL Gen 4)	
1	51637044	Valve Block	1
2	51048524	Seal Ring	1
3	51347445	Pressure Limiting Valve	1
4	50453256	Check Valve	1
5	51637045	Plug	1
6	51248335	Coupling	1
7	51637048	Pump Motor	1
8	51482662	Piping	2
10	51379966	Oil Filter	1
11	51637055	Hydraulic Tank	1
12	51057393	Breather & Dip Stick	1
13	50426545	Snap Ring	1
14	51637056	Plug	1
15	51637057	Solenoid Valve	1
16	51599237	Magnetic Coil	1
17	51637062	Throttle Valve	1
18	51588730	Plug	1
19	51637064	Clamp	1
20	51637066	Hydraulic Pump	1
21	51637067	Pipe	1
22	* 6-6 C40MXS	90 Male Elbow 3/8 BSPP (for Rexroth Pump)	1
23	** 51637068	Grounding	1
24	5204K16	Rexroth pump metal bolt clamp (4-9/32" to 4-19/32")	1
25	9833K11	1/2" Breather Vent	1
26	# DM106	Rexroth XL Hydraulic Tank	1

\* For Drum-Hauler serial # C23051 to present (using ELE51495653)

\* For ELDR serial # I23013 to present (using ELE51495653)

\* For EL serial # A24024 to present (using ELE51495653, verify on QC)

\*\* Used only on DH800-style Drum-Haulers

# First used on A25032

# EMPTY DRUM STACKER SINGLE CLAMPING MECHANISM ASSEMBLY

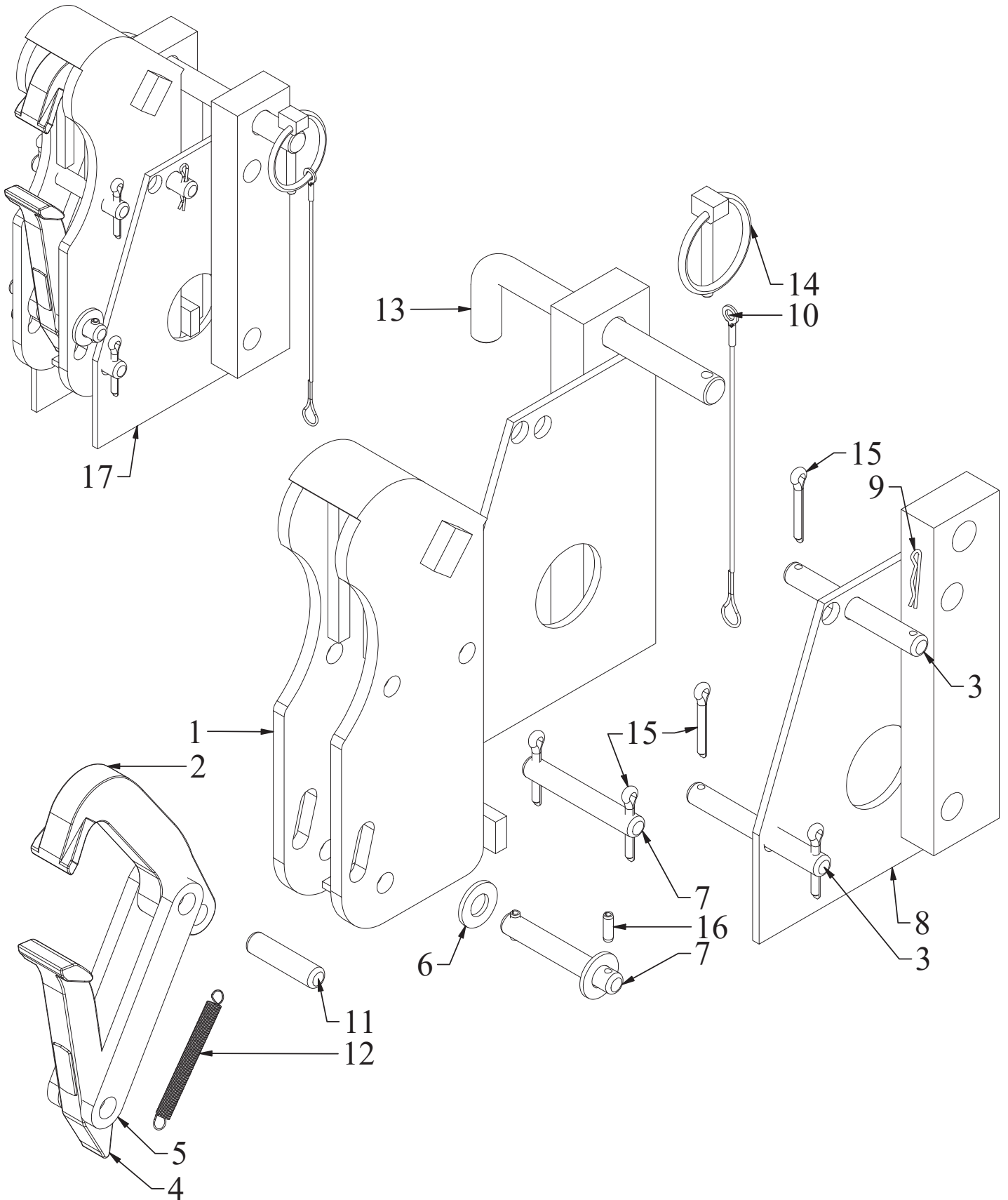

## EMPTY DRUM STACKER SINGLE CLAMPING MECHANISM PARTS LIST

<u>ITEM</u>	<u>PART NO.</u>	<u>DESCRIPTION</u>	<u>QTY</u>
1	6302	Housing (Black Powder Coating)	1
1	6302SS	Housing (Stainless Steel)	1
2	9107SS	Stainless Steel Upper Jaw (Spark Resistant)	1
3	15104-1SS	3/8" x 2.242" Pin, Fibre Guard, Housing to Clevis (stainless steel)	2
4	7107SS	Stainless Steel Lower Jaw (Spark Resistant)	1
5	13009-1	Link, Jaw to Jaw (zinc)	2
6	1470-6	Custom Washer EG (Stainless Steel)	2
7	16104-1SS	3/8" x 1.770" Pin, Upper Jaw Link (stainless steel)	2
8	8002EDM	Adjustment Slide & Plate (Black Powder Coating)	2
9	213	Hitch Pin Clip (zinc)	1
10	30345T527	6" 18-8 SS 3/64" Wire Rope Lanyard, Straight, Loop/Eye	1
11	41041SS	3/8" x 1" Pin, Upper Jaw to Link, short (stainless steel)	1
12	1206S	Empty Drum Stacker Spring, Jaw to Housing (zinc)	1
13	10204-1SS	1/2" x 4-1/2" Adjusting Pin (stainless steel)	1
14	HANG-1	3/16 x 1-1/4 Shank Lynch Pin "Hang 1" (9016)	1
15	3006-CP	Cotter Pin, 1/8" x 3/4" (zinc)	5
16	5/32 x 1/2 Roll Pin	Stainless Steel 5/32 x 1/2 Roll Pin	2
 <b><u>FULL ASSEMBLY</u></b>			
17	9004EDS	EG1 Empty Drum Stacker Clamping Mechanism (Black Powder Coating)	
17	9004EDS-SS	EG1 Empty Drum Stacker Clamping Mechanism (Stainless Steel - Non-Sparking)	

## EMPTY DRUM STACKER PREVENTATIVE MAINTENANCE KIT PARTS LIST

<u>ITEM</u>	<u>PART NO.</u>	<u>DESCRIPTION</u>	<u>QTY</u>
12	1206S	Empty Drum Stacker Spring, Jaw to Housing (zinc)	1
14	HANG-1	3/16 x 1-1/4 Shank Lynch Pin "Hang 1" (9016)	1
15	3006-CP	Cotter Pin, 1/8" x 3/4" (zinc)	5
16	5/32 x 1/2 Roll Pin	Stainless Steel 5/32 x 1/2 Roll Pin	2
	B-800	12oz White Lithium Grease Can	1

## DCM0035L

### Technical Specifications

Nominal Voltage	12V	
Nominal Capacity	35Ah (20 Hr Rate to 1.75V/cell)	
Chemistry	Lead Acid -AGM	

### Physical Specifications

Length	195mm	7.68in
Width	130mm	5.12in
Height	164mm	6.46in
Height w/Terminal	180mm	7.09in
Weight (+/- 5%)	10.4Kg	22.9lbs
Terminal Type	INSERT TERMINALS	
Case Material	ABS	

### Charging Specifications

Charge Voltage	Battery	Per Cell
Float	13.5V~13.8V	2.25V~2.30V
Cycle	14.4V~15.0V	2.40V~2.50V
Max. Charge Current	9.9A	

### Capacity Specifications

5 Second Discharge Current	495A	
Self Discharge (to 80% capacity)	3 Months	91%
	6 Months	82%
	12 Months	64%
Internal Resistance	11mΩ(25°C)	

### Temperature Specifications

Operating Temperature Capability **-40° F (-40° C) to 140° F (60° C)**

Recommended parameters for optimal battery life and performance:

Charging: 32° F to 104° F (0° C to 50° C), Discharging: 5° F to 122° F (-15° to 50° C),

Storage: 50° to 77° F (10° C to 25° C)



### FEATURES:

- Long life for deep discharge uses
- Ideal for applications using major capacity prior to recharging
- Depth of discharge should be between 50% & 80% and recharged as soon as possible
- Flexibility of mounting orientation
- VRLA technology to eliminate spills and over-pressurization
- Maintenance-free

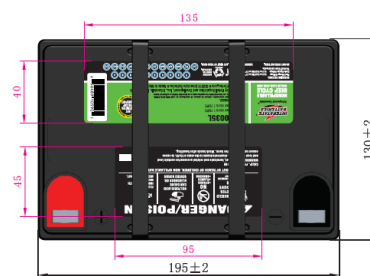

FOR REFERENCE ONLY  
HANDLE TRUE TO PHOTO ABOVE

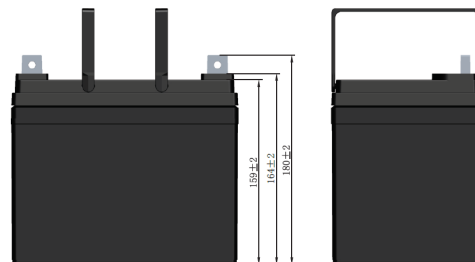

Storage Characteristics

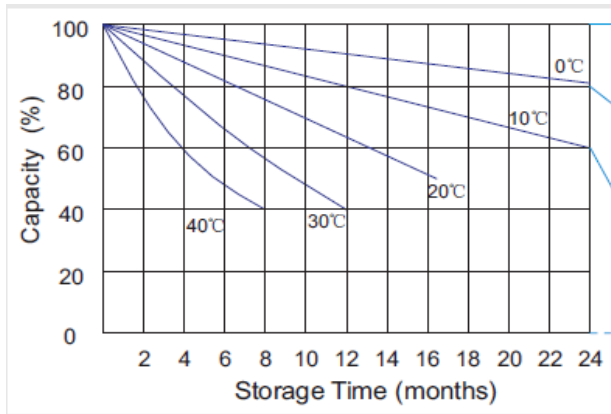

Cycle Life of Deep Cycle

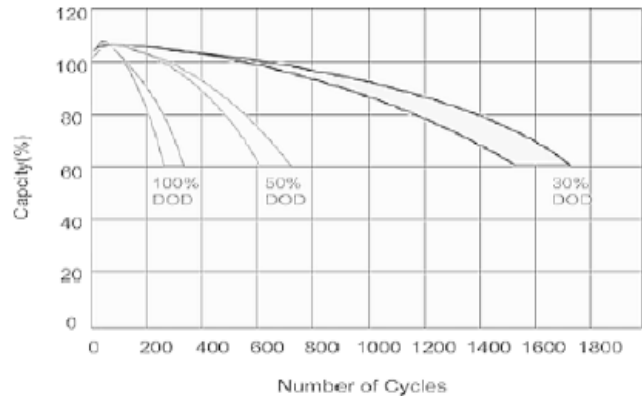

Constant Current Discharge Characteristics: A (25°C)

F.V/Time	5 min	30 min	1 hr	3 hr	5 hr	10 hr	20 hr
1.85V/cell	42.00	26.00	16.50	7.63	5.26	3.12	1.75
1.80V/cell	51.70	28.90	18.50	8.28	5.64	3.30	1.77
1.75V/cell	60.00	31.20	19.30	8.60	5.83	3.33	1.79
1.70V/cell	64.70	32.70	19.09.00	8.83	5.93	3.37	1.82
1.67V/cell	69.90	34.00	20.60	9.08	6.10	3.44	1.84
1.60V/cell	75.60	35.60	21.30	9.27	6.24	3.47	1.85

Constant Power Discharge Characteristics: W (25°C)

F.V/Time	5 min	30 min	1 hr	3 hr	5 hr	10 hr	20 hr
1.85V/cell	78.30	50.00	32.00	14.90	10.30	6.17	3.51
1.80V/cell	95.10	54.90	35.60	16.10	11.00	6.53	3.53
1.75V/cell	109.10	59.00	37.10	16.70	11.40	6.59	3.56
1.70V/cell	116.10	61.60	38.20	17.10	11.60	6.65	3.63
1.67V/cell	124.40	63.70	39.30	17.50	11.90	6.78	3.67
1.60V/cell	132.40	66.10	40.40	17.80	12.10	6.85	3.68



# PRO Charging Systems

## Installation and Operating Instructions (for chargers shown below)

### Industrial SERIES



**IS1- One 6 amp output**



**IS2- Two 6 amp outputs**



**IS3- Three 6 amp outputs**

*For additional information please call our  
Technical Support Group 800.742.2740*



081512

PRO CHARGING SYSTEMS, LLC  
1551 Heil Quaker Boulevard, LaVergne, TN 37086-3539

**INSTALLATION AND OPERATING INSTRUCTIONS  
FOR THE FOLLOWING BATTERY CHARGING SYSTEMS:**

Model #	Description	Total Output	Independently charge 12V batteries in the following systems:
Recreation Series			
IS1	One 6 Amp Bank	6 Amps	12V
IS2	Two 6 Amp Banks	12 Amps	12V, 24V
IS3	Three 6 Amp Banks	18 Amps	12V, 24V or 36V

**IMPORTANT NOTICE**

*Please save and read all safety, operating and installation instructions before installing or applying AC power to your PCS on-board battery charging system. Please contact PCS with any product, installation, or service questions at technical support (800.742.2740).*

**INTRODUCTION**

Pro Charging Systems (PCS) has been manufacturing waterproof, on-board battery charging systems since 1989. Our charging systems are designed and built tough to withstand intense vibration, extreme temperature variations and submersion without damaging the unit. Our systems use temperature compensation in order to fully charge a battery in hot or cold environments and are controlled by microprocessors in order to assure precise control over each totally independent charging bank. All of our chargers have true reverse polarity protection and incorporated a float maintenance mode upon completion of each charge cycle.

<b>TABLE OF CONTENTS</b>	
Important Safety Instructions.....	Pages 2-3
Product Summary.....	Pages 4-5
Installation Instructions.....	Pages 5-6
Trouble Shooting.....	Page 7
Warranty Information.....	Page 8

**IMPORTANT SAFETY INSTRUCTIONS**

Use of attachments not recommended or sold by PCS may result in a risk of fire, electrical shock, or injury to persons.

To reduce risk of damage to the electrical plug and power cord, always pull by the plug rather than by the power cord when disconnecting charger.

When using an extension cord, make sure:

1. That pins on the extension cord plug are the same number, size and shape as those of the charger's plug;
2. That extension cord meets UL (Underwriters Laboratories, Inc.) acceptance and is in proper operating condition;
3. That wire size is large enough for the ac ampere rating of charger.

Do not operate charger with a damaged cord or plug—replace the cord or plug immediately.

Do not operate charger if it has received a sharp blow, been dropped or otherwise damaged in any way; contact our technical support group for assistance (800.742.2740).

Do not disassemble charger; contact technical support when service or repair is required. Incorrect reassembly may result in risk of electrical shock or fire.

To reduce risk of electrical shock, unplug charger from outlet before attempting any maintenance or cleaning.

### **WARNING: RISK OF EXPLOSIVE GASES**

1. **WORKING IN THE VICINITY OF A LEAD-ACID BATTERY IS DANGEROUS.** Batteries generate explosive gases during normal battery operation. For this reason, it is of utmost importance that each time before using your charger, you read this manual and follow the instructions exactly.
2. To reduce risk of battery explosion, follow these instructions and those published by the battery manufacturer and by the manufacturer of any equipment you intend to use in the vicinity of battery. Review all cautionary markings on any product being utilized in or around the charging device.

### **PERSONAL PRECAUTIONS**

Someone should be within range of your voice or close enough to come to your aid when you work near a lead-acid battery.

Have plenty of fresh water and soap nearby in case battery acid contacts skin, clothing, eyes, or other surfaces.

Wear complete eye protection and clothing protection. Avoid touching eyes while working near battery.

If battery acid contacts skin or clothing, wash immediately with soap and water. If acid enters eye, immediately flood eye with running cold water for at least 10 minutes and seek medical attention.

NEVER smoke or allow a spark or flame in the vicinity of a battery or engine.

Be extra cautious to reduce risk of dropping a metal tool onto battery. This might cause a spark or short-circuit a battery, possibly resulting in an explosion.

Remove personal metal items such as rings, bracelets, necklaces, and watches when working with a lead-acid battery. A lead-acid battery can produce a short-circuit current high enough to weld a ring, or the like, to metal, causing a severe burn.

Use charger for charging a LEAD-ACID (lead acid, sealed lead acid, gel cell, and AGM) battery only. It is not intended to supply power to a low voltage electrical system other than in a starter-motor application. Do not use battery charger for charging dry-cell batteries that are commonly used with home appliances. These dry cell batteries may explode, causing personal injury and damage to property.

NEVER charge a frozen battery.

## **PREPARING TO CHARGE**

If it is necessary to remove the battery or batteries to charge, always remove grounded terminal from battery first. Make sure all accessories are off, so as not to cause battery arcing.

Be sure the area around any battery is well ventilated while batteries are being charged. On occasion, “gas fumes” may be present during charging and can be forcefully blown away by using a piece of cardboard or other nonmetallic material as a fan. Proper ventilation is always recommended in the charging area.

Clean all of the battery terminals. Be careful to keep corrosion from coming into contact with eyes.

Add distilled water in each cell (wet cell batteries) until battery acid reaches level specified by battery manufacturer. This helps purge excessive gas from cells. Do not overfill. For a battery without cell caps, carefully follow manufacturer’s recharging instructions.

Study all battery manufacturers’ specific precautions such as removing or not removing cell caps while charging and recommended rates of charge.

Extension cords should be industrial grade/heavy duty UL approved and grounded. Check extension cord before use for damage, bent prongs and cuts. Replace if damaged.

Always make your extension cord connection on the charger side first. After connecting the extension cord to the charger, proceed to plug the extension cord into a 120VAC GFCI protected (Ground Fault Circuit Interrupt) A/C outlet. The unit will operate with a VAC input range of 90VAC-264VAC.

Always remove the extension cord from the A/C outlet first when charging is completed followed by unplugging the charger.

## **PRODUCT SUMMARY**

### **General Operation:**

Use the following guidelines in this manual to install your fully automatic PCS battery charging system.

Assure that the area around your charger and batteries is properly ventilated. Connect your extension cord with no A/C power present to the battery charger and proceed to plug your extension cord in at a nearby A/C outlet.

Once you plug in your PCS battery charging system, your batteries will be simultaneously and independently charged to 100%. Unlike systems that utilize one large charger to attempt to charge multiple batteries, your system utilizes a totally independent battery charger for each battery. Each charging bank will remain in a “float” stage once the battery is charged and then monitor and/or maintain the battery indefinitely.

We recommend that you leave your system plugged in. This will reduce sulfation on the lead plates of the batteries and allow your PCS charging system to keep your batteries fully maintained and ready to perform at their best.

### **Independent Charging Bank Indications**

When your battery charging system is activated, each bank provides charging information utilizing 1 red Light Emitting Diode (LED) indicator and one green Light Emitting Diode (LED) indicator. The Red (CHARGING) LED indicates d/c current is flowing to the battery and the Green (READY) LED indicates that the charger has finished it’s bulk and absorption stage and has entered the float maintenance mode. There is also a Green (POWER) LED that illuminates to indicate that power is supplied to the charger when it is plugged in properly to a functioning A/C outlet.

Below is an example of the display on a Three output Industrial Series Charger (IS3):

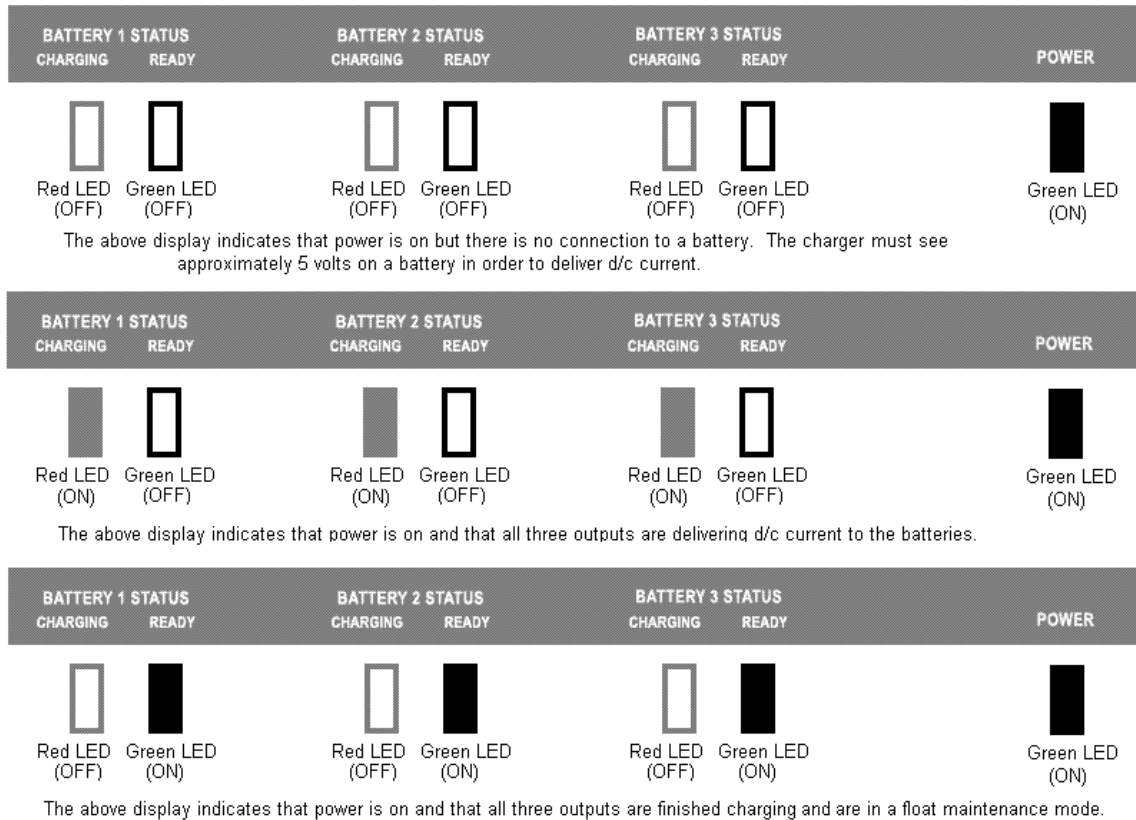

## **INSTALLATION INSTRUCTIONS**

All PCS battery charging systems are designed to be permanently installed in a well-ventilated area and have no mounting restrictions.

Do not make any electrical connections to the power supply (AC) or to a battery (DC) until the installation process has been completed.

If mounting the charger in a boat, please choose a flat surface as high above the water level as possible. If a compartment wall is chosen, make certain its strength is adequate to support the weight of the charger.

Use the mounting flanges of the charger to mark locations for starter holes. Drill a 1/16 inch hole at each marked location. Then, utilize all stainless steel screws that have been provided and install the charger securely, being cautious not to over tighten the screws. Silicon sealer should be used to secure and waterproof the screw holes.

### **IMPORTANT NOTICE**

The mounting brackets of the system may contain keyholes that are designed so that screws can be started before putting the charger into place. If applicable, the keyhole locations vary depending on which model you own.

Before making any connections, prepare batteries as follows:

- (a) With caps securely in place, thoroughly clean the case and posts with a solution of baking soda and water. Be careful not to allow any baking soda to get inside the case.

- (b) All posts, terminals, and connectors should be cleaned to a shiny bright finish, using a wire brush or sand paper. This should be done periodically to assure maximum conductivity between the battery and the charger.

Each charge cable assembly is equipped with a temperature sensor located at the junction of each set of ring terminals. Attempts to shorten the cables could partially disable the charger. Therefore, we recommend that you do not make any adjustments without first consulting our technical support group (800.742.2740). Proper cable extensions may be purchased in 5', 10', and 15' lengths. See picture below.

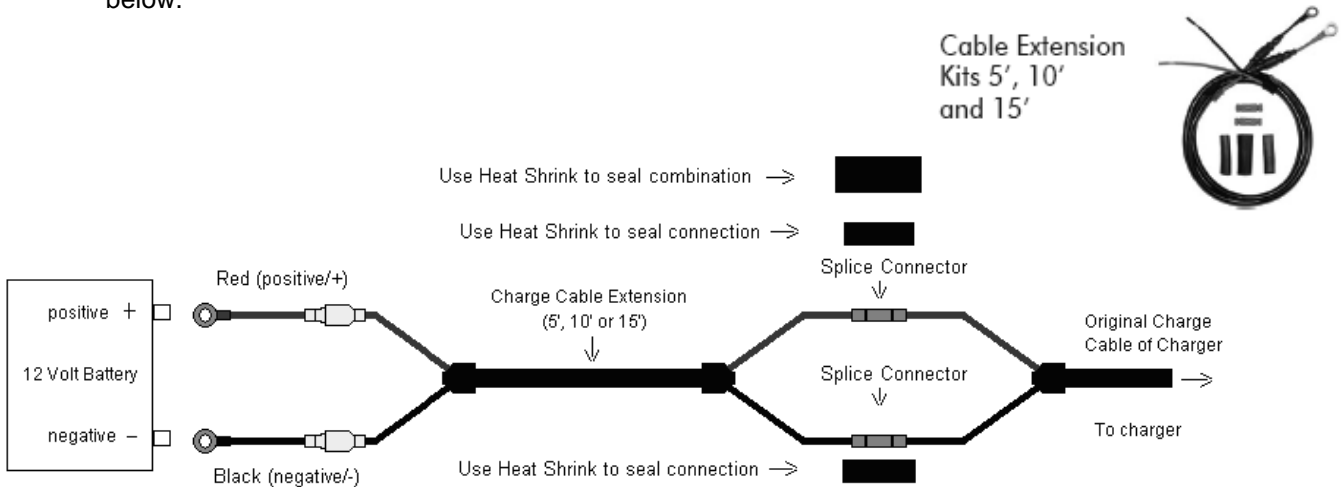

To connect the charger to the battery (batteries), route your charge cables from the charger to the batteries, being cautious to avoid sharp objects, and use the supplied wire ties to hold them securely and neatly in place.

Securely attach each charge cable independently to one 12V battery by connecting the red (positive/+) lead ring terminal to the positive (+) battery post and the black (negative/-) lead ring terminal to the negative (-) battery post. See picture below:

*The charger pictured is a **Professional Series Dual Pro**, which has two independent 15 amp outputs.*

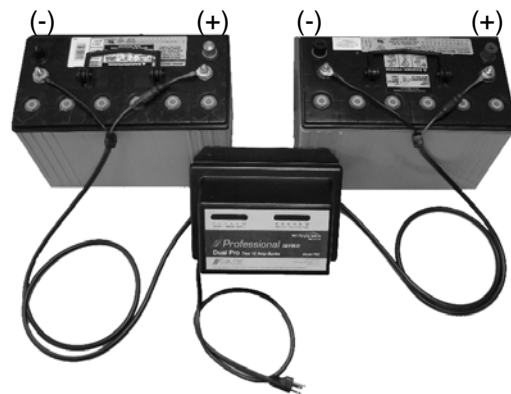

Connect a heavy duty UL approved extension cord to the power cord of your charger and then plug the extension cord into a nearby 120VAC GFI protected (Ground Fault Circuit Interrupt) outlet. You should now observe a red LED indication on each bank of the charger representing each individual battery being charged. The voltage of each battery will reflect the number of LED indicators illuminated.

When charging is complete, remove the extension cord from the 120VAC outlet first and then unplug the charger.

## **TROUBLE SHOOTING**

**PROBLEM: No LED indicators illuminate on the charger.**

Solution Sequence: Check the AC power supply from its source through all connecting points up to the charger by using a meter or test light to confirm that current is being delivered to the charger.

**PROBLEM: The Green (POWER) LED is illuminated, but the Red (CHARGING) LED and the Green (READY) LED are off.**

Solution Sequence: This indicates that the charger does not recognize that it is connected properly to a battery that has at least 2Volts. With the AC power supply cord unplugged, check the ring terminals for correct polarity (Red to positive or +) and (Black to negative or - ). Also check for corrosion free secure connections to the batteries. Check in-line fuses in charge cable for any signs of opening or corroded connections. Call the technical support group for further assistance (800.742.2420).

**PROBLEM: The RED (CHARGING) LED remains illuminated for more than 16 hours and the Green (READY) LED does not come on.**

Solution Sequence: This indicates that the battery is not reaching a sufficient voltage to indicate that the battery is fully charged. Disconnect AC power to the charging system. On multi bank chargers, remove the charge cable assembly of the affected bank from the battery and attach it to another battery in the boat. Take the original charge cable assembly from this battery and attach it to the battery from which you removed the first cable. Plug the charger in and observe the LED indications. If the rapid LED sequence (red to green repeatedly) occurs on a different bank of the charger, this confirms the existence of a battery problem.

On single bank systems, simply try the charger on another battery. If the charger now operates normally (steady red LEDs or changes to green and holds), this indicates a possible problem with the original battery.

If the same bank continues to malfunction, please call our technical support group (800.742.2740).

**PROBLEM: The green (READY) LED was illuminated before disconnecting the power from the charger, but upon reconnection, the red (CHARGING) LED appears and remains on.**

Solution Sequence: This is normal operating procedure for the system and simply indicates that a re-analysis of the battery status has been initiated and after a series of steps, the green LED will illuminate.

## LIMITED WARRANTY

Pro Charging Systems, LLC (PCS) makes this Limited Warranty only to the original retail purchaser.

PCS warrants this battery charger for 18 months from the date of retail purchase against defective materials and/or workmanship. If such defects should occur, this unit will either be repaired or replaced at the discretion of the manufacturer. It is the responsibility of the original purchaser to return the charger along with proof of purchase, transportation, and/or any mailing or handling charges prepaid to the manufacturer or its authorized representative.

This limited warranty is void if the product is misused, improperly maintained, handled carelessly or incorrectly operated. Additionally, this warranty is void if the charger is disassembled, the charger's charge cables are cut, the power cord is cut off, the charger is altered without authorization from PCS, the serial number is removed, or repair is attempted by anyone other than an authorized representative.

PCS makes no other warranty other than this limited warranty and expressly excludes any implied warranty, including warranty for any incidental or consequential damages.

This is the only expressed limited 18 month warranty authorized by PCS and does not authorize anyone to assume or make any other obligation towards the product other than this three year Limited Warranty. Some states do not allow limitation of incidental or consequential damages.

This warranty gives you specific legal rights and you may also have other rights which vary from state to state.

Please call Pro Charging Systems, LLC (800.742.2740) for full warranty information and/or service.

Below are some of our other options in chargers and battery accessories. Call our technical support group for more detailed information or visit our web site [www.dualpro.com](http://www.dualpro.com).

### Professional SERIES

Uni Pro  
One 15 Amp  
Bank



Dual Pro  
Two 15 Amp  
Banks



Tri Pro  
Three 15 Amp  
Banks



Quad Pro  
Four 15 Amp  
Banks



### Sportsman SERIES

Uni Pro  
One 10 Amp  
Bank



Dual Pro  
Two 10 Amp  
Banks



Tri Pro  
Three 10 Amp  
Banks



Quad Pro  
Four 10 Amp  
Banks



### Eagle Performance SERIES

Available in 12 to 48 Volts  
and 9 to 25 Amps



### Charge On The Run SERIES

12 Volt, Available in 1, 2 or 3  
Banks



### Go Charge

Maintainer/Charger  
Available in 1.25 Amp and  
2 Amp Units



For more information and products:

[www.dualpro.com](http://www.dualpro.com)

Technical Support: 800.742.2740

### Accessories

Cable Extension  
Kits 5', 10'  
and 15'



Remote Battery Status  
Indicators 2 and 3 Banks

