

# Easy Lift Equipment Co., Inc.

2 Mill Park Court, Newark, Delaware 19713 - Phone: 800-233-1800 / 302-737-7000

## EASYLIFT PNEUMATIC DRUM TRANSPORTER WITH EG1 OR EG2L OPERATION & MAINTENANCE INSTRUCTIONS



# **EASY LIFT EQUIPMENT EASYLIFT PNEUMATIC AIR POWERED ERGONOMIC DRUM TRANSPORTER WITH EG1 OR EG2L OPERATIONS & MAINTENANCE INSTRUCTIONS**

## **INTRODUCTION**

EasyLift Pneumatic Air powered ergonomic drum transporters utilize an automatic clamping mechanism for handling a steel, plastic, or fiber chimed drum. These models are available in capacities of up to 600 lbs. (270 kg). The specification plate affixed to each unit provides the following information: model number, serial number, unit weight, and lifting capacity.

This manual contains information to help instruct operators on the proper use and maintenance of your EasyLift Pneumatic Air powered ergonomic drum transporter. This manual should be made available to all operators who will use this equipment. Properly following the maintenance procedures will help ensure a safe and reliable service life. Do not operate this equipment until you have read and understand these instructions.

## **COMMISSIONING YOUR ERGONOMIC DRUM TRANSPORTER**

1. Perform a visual inspection for potential damage, including checking for hydraulic oil leaks or visual damage to the air tank, lines and components.
2. Remove all packing materials, protective strapping, and wood shipping blocks. It is recommended to use protective eye gear when cutting any metal strapping. Then, using a company forklift, carefully lift and remove the drum transporter from the shipping pallet or crate.
3. Perform a visual inspection for component damage. Checking for hydraulic oil leaks.
4. Check that the ergonomic step-down floor lock is functioning properly by depressing the small portion of the step-down pedal to release the floor lock. To engage the floor lock, depress the large portion of the step-down pedal, which will engage contact with the floor and secure the equipment in place. With the floor lock disengaged, check that the caster wheels are free of obstruction and functioning properly.
5. Pneumatic drum transporters utilize a 3-position directional valve to control the lift and lower function of the drum transporter. To help prevent shipping damage the valve has been packaged safely in a box and needs to be installed and connected before usage. To install the valve and prepare the unit for operation, please follow the instructions below:

(Seen on next page)

- I. Place the 3-position directional valve on the mounting plate and secure using the (3) 8-32 x 1 1/4 Phillips truss head screws (circled in red).
- II. Connect the 1/4" air line from the air tank to the right of the regulator with gauge (circled in blue).
- III. Connect the 1/4" air line from the lift cylinder to the left of the valve (circled in green).
- IV. Your pneumatic drum transporter is now available for use.

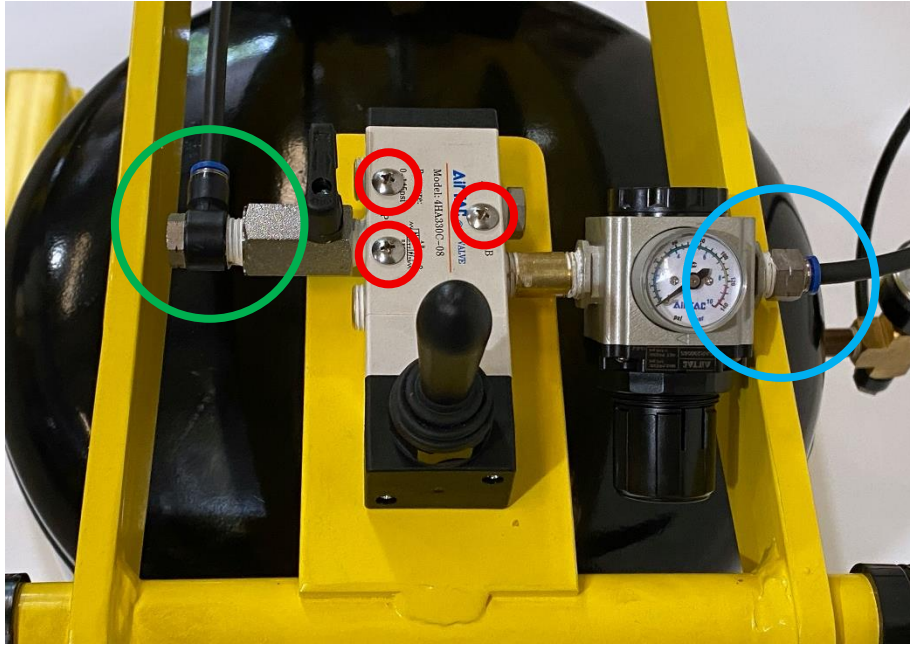

6. For safety reasons, all pneumatic drum transporters are shipped with empty air tanks. Filling the tank is required before the Drum Transporter can be operated. Air tanks feature an industrial shape male 1/4" hose coupling to accept an end user supplied female 1/4" sleeve-lock socket (coupling).
7. To fill the air tank, insert a female 1/4" sleeve-lock socket (coupling). The drum transporter air tank is rated for 200 psi, but a factory installed safety valve limits the air pressure to a maximum of 150 psi. A pressure gauge displays the active air pressure in the tank at any given time. Once the air tank has reached the end user air system supplied psi, you can disconnect the air hose for portable use. (Note: The airline can remain connected for consistent use).
8. Next open the airline to the cylinder.

CLOSED

OPEN



9. Check that the lift and lower functions are working properly by pressing the joystick both forward and backwards, to ensure proper operation of each function.

### DAILY SAFETY INSPECTION

1. Perform a visual inspection, checking for any evident damage to the machine or any hydraulic oil leakage from previous use. Check all hydraulic fittings, air lines, air tank, other components and connections, and look under the machine itself for leaks.
2. Ensure that the step-down floor lock is functioning properly and that the wheels are free of obstructions.
3. Perform a visual inspection, checking for loose or damaged springs and jaws in the clamping mechanism.
4. Verify that lift and lower functions are in proper working order by pushing the joystick in both the “UP” and “DOWN” positions. Observe the condition of the equipment for any other malfunction or defect.

**Do not operate your EasyLift Drum Transporter if you notice any unsafe conditions that may have been caused by an accident or malfunction from previous use. Immediately report any unsafe conditions or issues with the equipment to your supervisor. Tag the drum transporter properly to keep others from using it until the issue has been corrected.**

### SAFETY PRACTICES

1. Do not lift loads that exceed the drum transporter’s rated capacity.
2. Only lift the drum to the minimum height needed for proper floor clearance while transporting the drum to its destination. Do not transport or move a drum at heights greater than 6” (15cm) above floor level.
3. **Always** keep hands, feet and other objects clear of any pinch points, including mast channel(s), lifting and rotation chains (where applicable), the clamping mechanism(s), lift cylinder and *any* other moving parts. Also keep your hands and feet clear of the lifting area at the front of the unit.
4. Do not use the drum transporter on inclined floors having a slope of more than 5°.
5. Never lay the drum transporter down horizontally.

## WARNINGS

- WARNING:** NEVER lift or suspend loads over people. Stay clear of suspended loads.
- WARNING:** Do not attempt to operate the equipment beyond its rated capacity and do not attempt to lift the drum beyond its maximum lifting height.
- WARNING:** Never move the drum transporter when the load is at its maximum lifting height. Lower the mast so the drum has only the necessary floor clearance for transport.
- WARNING:** Keep hands and feet away from pinch points, such as mast channel, lifting & rotation chains (if applicable), clamping mechanism, lift cylinder and any other moving parts.
- WARNING:** Do not make alterations or modifications to the drum transporter without authorization from Easy Lift Equipment.
- WARNING:** Do not leave the drum transporter outside in inclement weather for extended periods.
- WARNING:** Never leave the drum transporter unattended without first applying the step down foot floor lock. Leaving the drum transporter unsecured may allow it to move inadvertently and cause property damage or personal injury.
- WARNING:** Never operate the drum transporter on an inclined floor with a slope of more than 5°.
- WARNING:** Easy Lift Equipment's pneumatic and air-powered models are built with anti-static and non-sparking components. These units have not been submitted for third-party certification and contain no electrical components, except for the optional scale system, which carries its own independent approval.

## **EASYLIFT PNEUMATIC ERGONOMIC DRUM TRANSPORTER OPERATING INSTRUCTIONS**

### **TO ENGAGE, PICK AND TRANSPORT A DRUM:**

1. To begin, press forward on the air valve joystick to ensure that the lower clamping jaw rests below the chime of the drum that you want to pick up. If the lower clamping jaw does not lower below the drum's chime, refer to the instructions below for adjusting the height of the clamping mechanism on the mast. Once the clamping mechanism is appropriately set and lowered, approach the drum head-on and push the equipment forward until the clamping mechanism makes full, solid contact against the drum (which will cause the clamping mechanism to collapse downward). Keep the clamping mechanism pressed tightly against the drum and pull back on the air valve joystick until the lower clamping jaw engages with the chime of the drum. It is recommended to apply slight forward pressure while raising the clamp to help ensure a secure grip.
2. The weight of the drum on the lower clamping jaw will activate the mechanism causing the upper jaw to clamp down on the chime, securing the drum. After the clamp is securely engaged continue to pull back on the joystick until the drum is elevated slightly above the pallet or floor level for safe travel.
3. Only lift the drum to the minimum height needed for proper floor clearance while transporting the drum to its destination. Do not transport or move a drum at heights greater than 6" (15cm) above floor level.

### **TO RELEASE A DRUM:**

1. Once you have arrived at the required destination, press forward on the air valve joystick until the drum contacts the floor (or pallet) causing the upper clamping jaw to retract completely and allowing the drum to disengage from the clamp.

### **ADJUSTING THE CLAMPING MECHANISM FOR VARIOUS HEIGHT DRUMS:**

1. Remove the circle cotter pin & stainless-steel adjusting pin **while holding the clamping mechanism with your other hand (failure to hold the clamping mechanism while removing the adjustment pin could cause the clamping head to fall and cause injury)**. Raise or lower the clamping mechanism to the desired available position so that the lower clamping jaw rests slightly below the chime of the drum, with the drum at floor level. Re-insert the adjustment pin & circle cotter pin to secure the clamping mechanism into place. The lowest position available with the standard outer mast design will enable the lower clamping jaw of the clamping mechanism to rest at 17" (43.1cm) in overall height. This will allow you to pick drums where the bottom of the chime rests above 17" (43.1cm).

## **MODELS EQUIPPED WITH SCALE SYSTEMS**

If your equipment has a scale system, the indicator has already been factory calibrated and tested. The indicator has been disconnected and packaged separately for safe travel. However, due to the nature of LTL freight we recommend verifying calibration upon receipt. In some cases, re-calibration may be required and is not covered by Easy Lift Equipment. Unpack the indicator from the box and attach it to the mounting bracket. Once securely mounted, connect the corresponding male and female indicator cables. Non-Intrinsically safe scale indicators have internal batteries. Intrinsically safe indicators have external batteries which need to be mounted and have a separate battery cable that needs to be securely connected to the back of the indicator. All scale indicators are provided with a separate set of instructions that are packaged along with the indicator. Please read the scale indicator operations manual for more specific instructions of use.

Turn the indicator “ON” and ensure it reads zero before engaging a drum. Follow the instructions listed above for engaging a drum. If handling drums containing liquids operators should allow the contents of the drum to settle prior to documenting drum weights. This will help ensure the most accurate possible measurements. Most scale indicators are set to display the weight in increments of 0.1 lb. (0.05 kg). To speed up the process it is recommended to set the indicator to a lower sensitivity. This can be achieved by programming the indicator to read in 0.5 lb. (0.25 kg) or 1.0 lb. (0.5 kg) increments. Doing so will require less time for the indicator to settle on a specific weight.

## **MAINTENANCE INSTRUCTIONS**

1. Before every usage, check that all springs, pins, and casters are in good working order and that the hydraulic cylinder works properly and isn't leaking.
2. On a monthly basis, spray light grade oil on moving parts in the clamping mechanism to ensure smooth operation. It is recommended to keep the clamping mechanism lubricated and free from foreign materials which may impede proper operation of jaws and springs.
3. For heavy usage, it is recommended to replace all springs, hydraulic oil and sealing components of the hydraulic cylinder once each year.

# EASY LIFT AIR POWERED ERGONOMIC DRUM TRANSPORTER

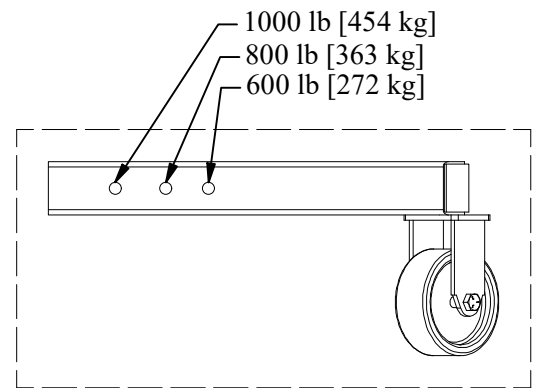
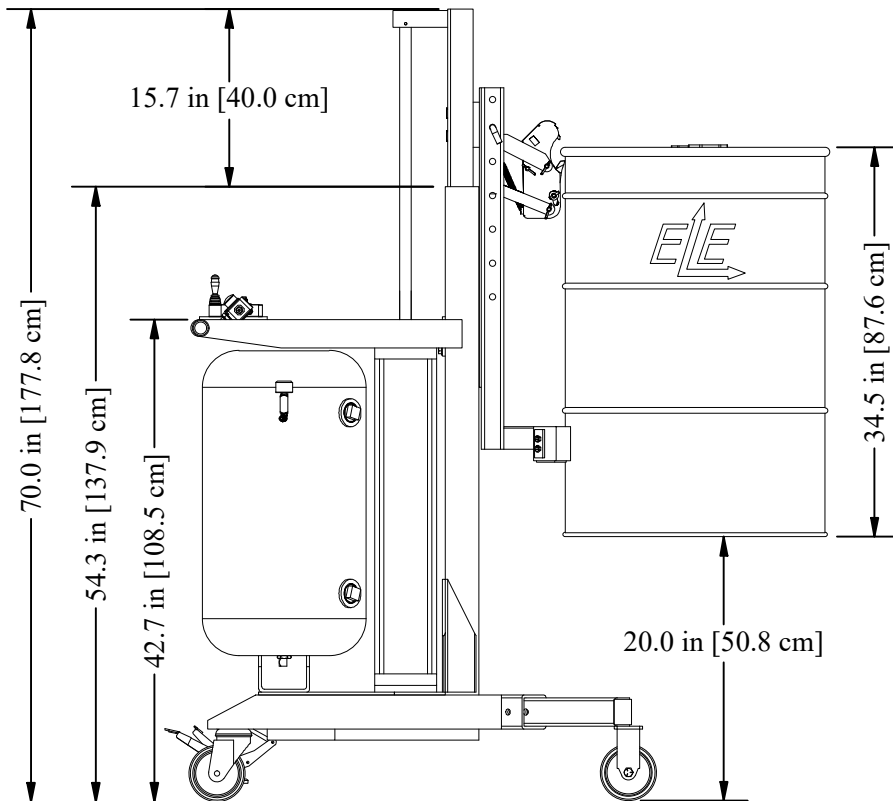
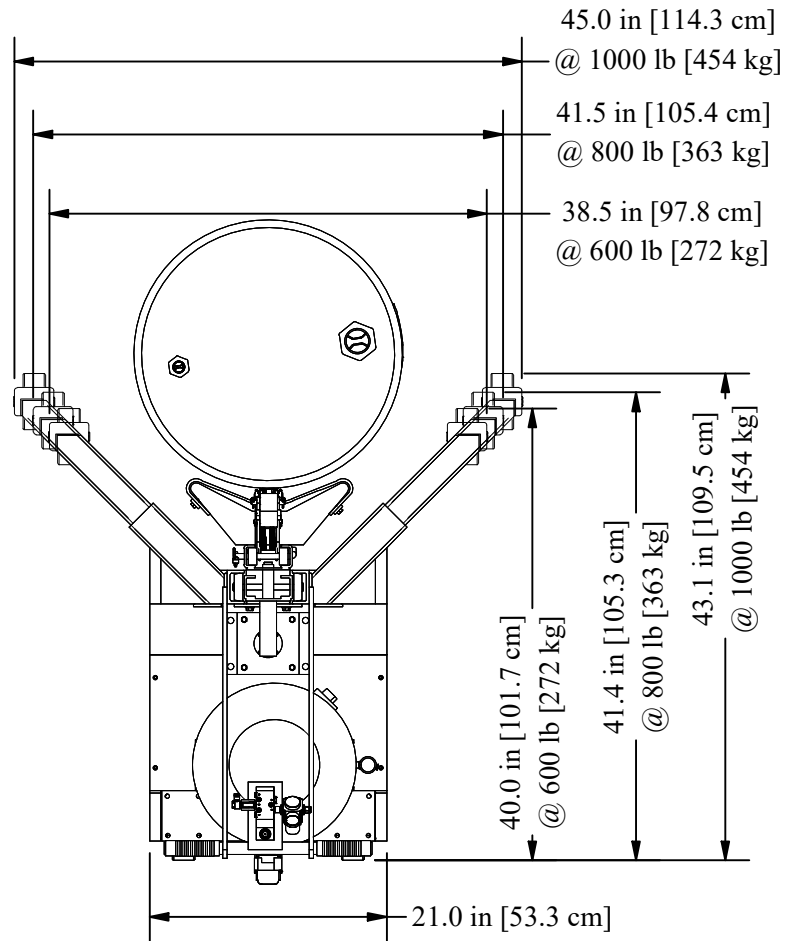
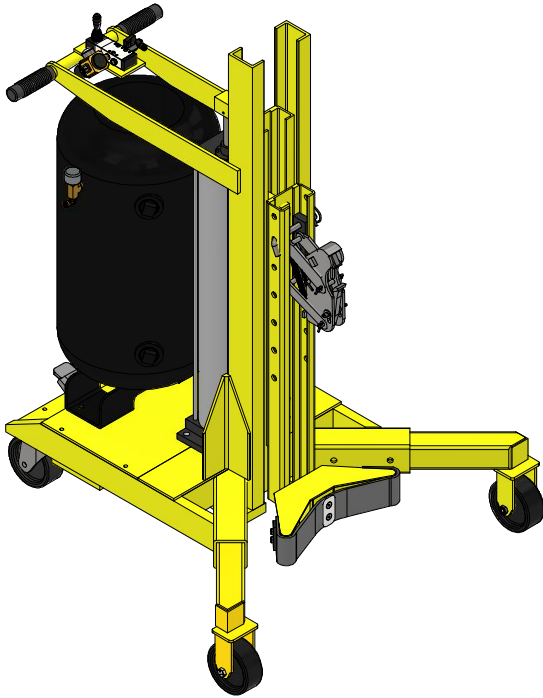

EL Leg Detail



EASY LIFT EQUIPMENT CO., INC.  
2 MILL PARK CT.  
NEWARK, DE 19713

MODEL: EL600A / EL800A / EL1000A  
MACHINED WEIGHT: 440 lb [200 kg]  
CAPACITY: 600 lb. [272 kg.] to 1000 lb. [454 kg.]  
VERTICAL LIFT: 20 in. [50.8 cm]

# **Easy Lift Equipment Co., Inc.**

**2 Mill Park Court, Newark, Delaware 19713 - Phone: 800-233-1800 / 302-737-7000**

## **Operator's Daily Checklist**

### **Drum Transporter (Air Powered) with Eagle-Grip® Clamp, V-Pan or Roll Post**

Inspections Performed by: \_\_\_\_\_

Note: This inspection must be made by the equipment operator **daily** at the start of the shift. Check (✓) the appropriate "OK" or "Needs Repair" field.

This Daily Checklist is intended to help verify that the equipment is in proper working order each day.

**More thorough Weekly, Monthly and Yearly Maintenance schedules should still be followed.**

		DATE:		/		/		/		/		/		/		
		OK	Needs Repair	OK	Needs Repair	OK	Needs Repair	OK	Needs Repair	OK	Needs Repair	OK	Needs Repair	OK	Needs Repair	
VISUAL CHECK																
<b>VISUAL CHECK: FRAME &amp; MAST</b>	<b>DATA PLATES &amp; WARNING DECALS</b> - Data Plates & Warning Decals are affixed to the unit and in good condition															
	<b>DAMAGE</b> - Look for bent, dented or broken parts. This includes hydraulic lines, electrical wires, frame welds, wheels, & bolted connections															
	<b>LIFT CHAIN (if applicable)</b> - Visually ensure lift chain is connected and not loose															
	<b>LIFT CYLINDER (if applicable)</b> - Ensure that the hydraulic lift cylinder appears in operable condition															
	<b>LEAKS</b> - Check for any leaking oil or hydraulic fluid															
	<b>GUARDS</b> - Verify that all chain guards are in place and in proper condition															
	<b>AIR TANK</b> - Verify that the Air Tank and all fittings and lines are in good condition and show no signs of damage or leaks															
<b>VISUAL CHECK: EAGLE-GRIP CLAMP</b>	<b>CLAMP DAMAGE</b> - Look for bent, dented or broken clamp components. This includes the clamp housing, the upper and lower clamping jaws, retaining pins, cotter pins, and springs															
	<b>CLAMP PINS</b> - Confirm that all retaining pins and cotter pins are accounted for and secure															
<b>VISUAL CHECK: V-PAN OR ROLL POST</b>	<b>V-PAN/ROLL POST DAMAGE</b> - Look for bent, dented or broken components. This includes all welds and bolted connections of both the V-Pan assembly and the Roll Post and mounting receiver, including all applicable safety pins, retaining pins, latching pins and cotter pins															
	<b>V-PAN/ROLL POST PINS</b> - Confirm that all applicable safety pins, retaining pins and cotter pins are accounted for and secure															
<b>VISUAL: SCALE</b>	<b>SCALE SYSTEM &amp; PRINTER</b> - If applicable, confirm that the scale and printer as well as all wires, lines and cables are in good condition and properly connected															

**Checklist Continued on Next Page**

# Easy Lift Equipment Co., Inc.

2 Mill Park Court, Newark, Delaware 19713 - Phone: 800-233-1800 / 302-737-7000

## Operator's Daily Checklist (cont.)

### Drum Transporter (Air Powered) with Eagle-Grip® Clamp, V-Pan or Roll Post

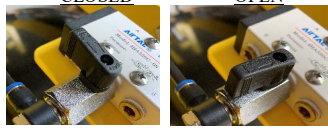
DATE:		/		/		/		/		/		/		/	
OPERATIONAL CHECK		OK	Needs Repair	OK	Needs Repair	OK	Needs Repair	OK	Needs Repair	OK	Needs Repair	OK	Needs Repair	OK	Needs Repair
OPERATIONAL CHECK: FRAME & MAST	<b>BRASS BALL VALVES</b> - Ensure that <b>both</b> the upper & lower brass ball valves on the unit are in proper working order <div style="display: flex; justify-content: space-around; font-size: small;"> <span>CLOSED</span> <span>OPEN</span> </div> 														
	<b>CHARGING THE AIR TANK</b> - With both Brass Ball Valves in the CLOSED position, charge the Air Tank, ensuring that the air tank holds a charge and shows no signs of leakage														
	<b>FOOT FLOOR LOCK</b> - Verify that the Foot Floor Lock engages and disengages properly														
	<b>WHEELS AND TRAVEL</b> - Confirm that the unit travels properly. Ensure that the wheels are aligned properly, unobstructed, and not damaged														
	<b>CONTROLS</b> - Verify that the lift and lower functions of the air valve toggle control is in proper working order by pulling (to raise) and pushing (to lower) the toggle control														
	<b>MAST</b> - Ensure the clamping head, V-Pan or Roll Post moves smoothly up and down the mast, with no obstruction or unusual noises														
EAGLE-GRIP	<b>EAGLE-GRIP CLAMPING HEAD</b> - Verify that the Eagle-Grip Clamping Head engages and disengages a drum properly. Only lift the "test" drum to the minimum height required while completing this test														
V-PAN OR ROLL POST	<b>V-PAN/ROLL POST FUNCTION</b> - Verify proper function of all V-Pan or Roll Post components, including smooth rotation of the Stainless Steel V-Pan tray (if applicable), as well as proper operation of Roll Post rollers and/or folding capabilities (if applicable)														
SCALE & PRINTER	<b>SCALE SYSTEM &amp; PRINTERS</b> - If applicable, power up the scale and printer. Ensure the scale and printer are in proper working order														

List the details of all required repairs in the comments section below. Then, **tag and decommission the equipment for safety.**

**Comments (items needing repair or adjustment):** \_\_\_\_\_

\_\_\_\_\_

\_\_\_\_\_

**Caution** – If the equipment is found to be in need of repair or in any way unsafe, or contributes to an unsafe condition, the matter shall be reported immediately to the designated supervisor, and the equipment shall not be operated until it has been restored to a safe operating condition. If during operation, the equipment becomes unsafe in any way, the matter shall be reported immediately to the designated supervisor, and the equipment shall not be operated until it has been restored to safe operating condition. Do not make repairs or adjustments unless specifically authorized to do so.

# Easy Lift Equipment Co., Inc.

2 Mill Park Court, Newark, Delaware 19713 - Phone: 800-233-1800 / 302-737-7000

## EASY LIFT EQUIPMENT WARRANTY POLICY FOR MODELS WITH PREFIXES: ED/ER/EL/ELDR/EG & RCR

**Easy Lift Equipment (“ELE”)** warrants each new product to be free from factory material and workmanship defects, under normal use with proper maintenance, for a period of 12 months. Warranty coverage for this warranty period is provided by authorized dealers and includes parts. Labor is covered for the same periods of 12 months as outlined above. Please call ELE for the authorized repair dealer in your area.

ELE shall be the sole judge of the validity of any claim or defect and may elect to make any replacement or repair of any part thereof that it has agreed to be defective. Wearable Items such as: hoses, bearings, belts, brushes, seals, lift motors, clamp motors, relays, fuses, springs and wheels are wear items not covered under the warranty policy. ELE assumes no responsibility whatsoever to work done, parts replaced, or expenses incurred not specifically authorized by ELE. Normal maintenance or replacement of service items is not covered by this warranty. No warranty claims will be considered for customers with any delinquent outstanding balance. When batteries, battery chargers, scale printers or scale indicators are purchased from ELE with the equipment, the original manufacturer’s warranty applies.

### **WARRANTY LIMITATION/DISCLAIMERS:**

Easy Lift Equipment reserves the right to void warranty coverage if the unit has been overloaded beyond rated capacity; damaged due to: abuse, misuse, neglect, accidents, freight damage, improper usage, improper repair, and/or improper storage; or any modification or repair conducted in a manner not approved by Easy Lift Equipment. Equipment used in freezers, abrasive, corrosive, and/or excessively moist conditions must be properly equipped for the environment to ensure the warranty is not voided. Warranty questions and claims should be directed to our customer service department. ELE customer service representatives will help you assess and resolve the claim or assist you in contacting the local authorized dealer or representative. The warranty described here shall constitute the sole remedy of the authorized dealer and/or the initial purchaser. ELE neither assumes nor authorizes any person to assume for it any other obligation or responsibility in connection with this product warranty. In no event shall ELE be responsible for direct, indirect, special or consequential damages or any other delay or any economic or commercial loss resulting from Easy Lift Equipment’s performance or non-performance under this warranty. This warranty is expressly in lieu of all warranties, obligations or responsibilities of ELE dealers or other authorized source, expressed, implied or statutory.

### **SUBMITTING CLAIMS:**

To make a claim under this policy, please contact Easy Lift Equipment for assistance. We can be reached by calling 800-233-1800 ext. 4 for customer service or by writing to [sales@easylifteqpt.com](mailto:sales@easylifteqpt.com). Do not return defective parts unless a return authorization (RA) has been provided requesting the return. If requested, we will provide shipping information on how the part should be returned and bear the expense for the return shipping, if the part is proven to be defective. A copy of the work order made at the time of the repair and parts claimed under warranty may be requested for ELE’s inspection.

### **ORDERING PARTS:**

Easy Lift Equipment’s parts are distributed through our customer service department and ship the same day as ordered whenever possible. You will be well taken care of whenever parts, adjustments or repairs are needed. **When contacting ELE, please be sure to state the model and serial number for the equipment.** There is no cost for electronic copies of replacement manuals, parts lists and other general information containing part numbers and nomenclature. Most manuals contain parts pricing, but it is not guaranteed to be valid as parts pricing can change at any time without notice. Any customer service representative can provide timely parts quotations upon request. Adherence to above procedure will save time and provide prompt assistance when it counts. You are of course always welcome to bring to us any questions, comments or recommendations pertaining to your Easy Lift Equipment products.

### **MANUFACTURER CONTACT INFORMATION:**

Easy Lift Equipment Co., Inc.  
2 Mill Park Ct.  
Newark, DE 19713  
Email: [sales@easylifteqpt.com](mailto:sales@easylifteqpt.com)

Phone: 800-233-1800: 302-737-7000  
Fax: 302-737-7333  
Website: [www.easylifteqpt.com](http://www.easylifteqpt.com)

# EASY LIFT EQUIPMENT FIBER DRUM EG1 CLAMPING PROCEDURE

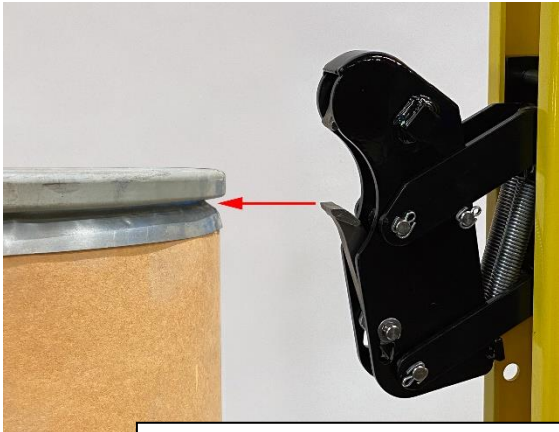

1. Raise the clamping mechanism until the lower jaw is just high enough to contact the metal skirt just below the locking band.

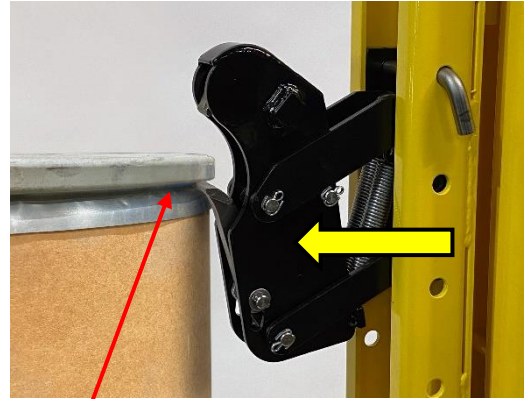

2. Then move the clamping mechanism forward so the lower jaw contacts the metal skirt under the drum's locking band and proceed to elevate the drum upward.



3. Maintain slight forward momentum while raising the drum so the lower clamping jaw maintains contact with the metal skirt. Do not allow the lower jaw to contact the paper portion of the fiber drum when elevating the drum.

## IMPORTANT:

It is important that the lower jaw does not contact the paper portion of the drum when raising the clamping mechanism. Keep the lower jaw away from the paper portion of the drum until the lower jaw of the clamping mechanism is high enough to contact the metal skirt below the locking band.

Then push the clamping mechanism forward to contact the skirt. Once contact has been made, proceed to elevate the clamping mechanism. If the lower jaw contacts the paper portion of the drum when elevating the drum, the clamping mechanism will attempt to clamp the drum in this position and miss or tear the skirt. If this is done incorrectly, lower the clamp and try again. The clamping mechanism can also grip the drum without the lid and locking band.

# EASY LIFT EQUIPMENT FIBER DRUM EG2L CLAMPING PROCEDURE

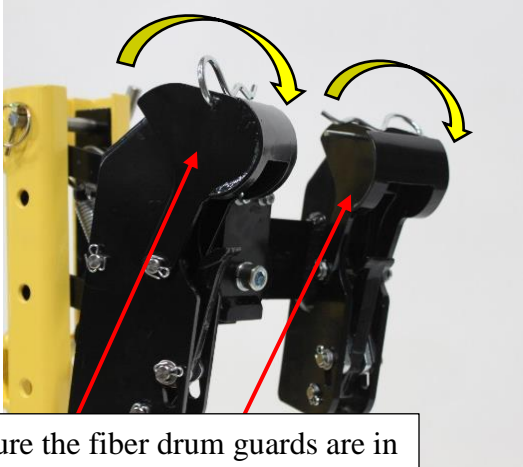

1. Ensure the fiber drum guards are in the forward position (closer to the clamp) and the cotter pins are locking the guards in place. The guards should always be in this position when handling fiber drums. The guards can be in the rearward position (closer to the mast) when handling steel or plastic drums.

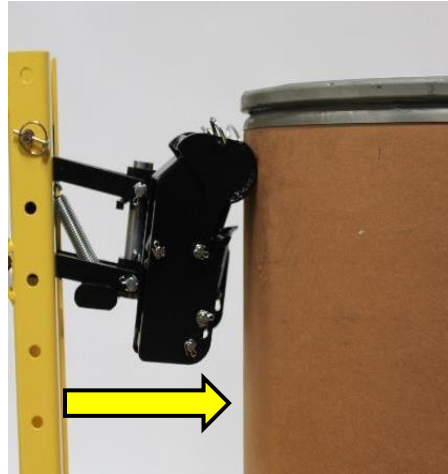

2. Push the unit forward so the fiber drum guards are contacting the paper portion of the drum.

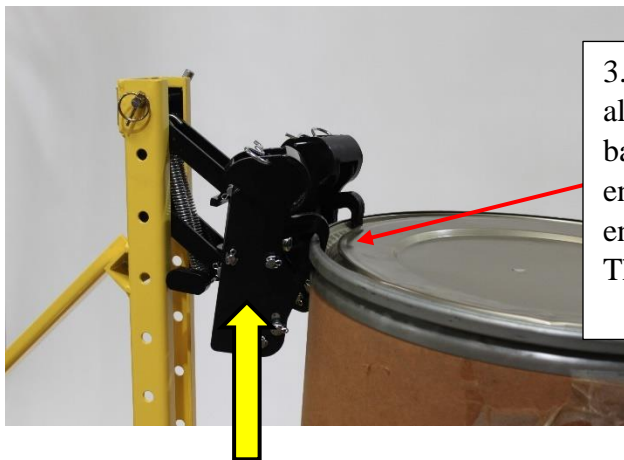

3. Elevate the clamping mechanism(s), allowing them to engage the locking band. After the clamp has fully engaged continue elevating the drum enough to ensure safe floor clearance. The drum can now be transported.

## IMPORTANT:

The fiber drum guards, when in the forward position, are designed to prevent the clamp from damaging the fragile paper portion of fiber drums. Great care should still be taken to ensure the clamping mechanism only contacts the metal skirt and locking band.

# EASYLIFT ERGONOMIC PNEUMATIC DRUM TRANSPORTER FRAME ASSEMBLY

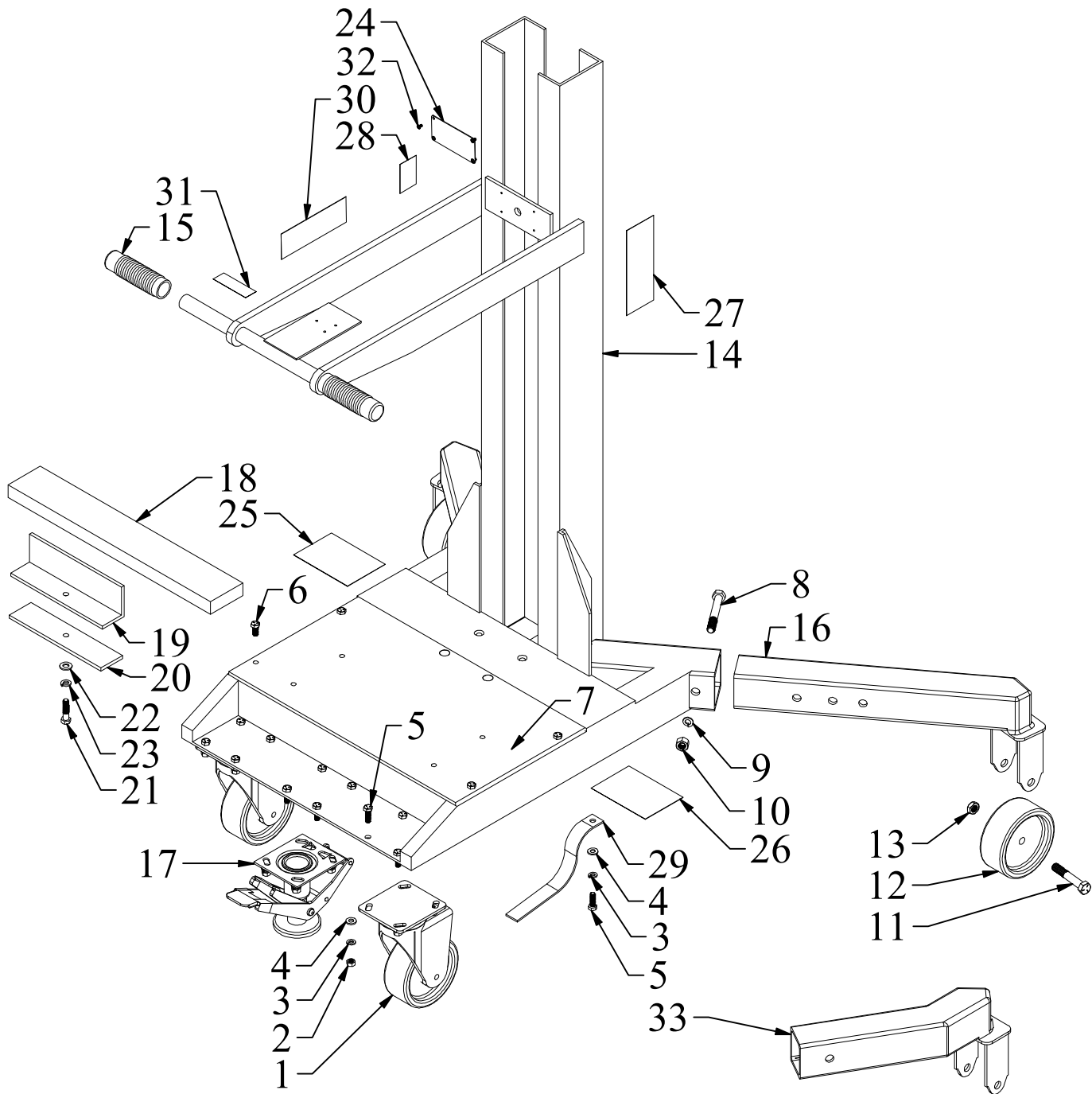

**EASYLIFT EROGNOMIC PNEUMATIC DRUM TRANSPORTER FRAME  
PARTS LIST**

<u>ITEM</u>	<u>PART NO.</u>	<u>DESCRIPTION</u>	<u>QTY</u>
1	31-405-PSE	5" Swivel Caster with PSE Wheel	2
-	W-405-PSE	5" PSE Wheel Only	-
1	31-408B-PSE	8" Swivel Caster with PSE Wheel & Brake	2
-	W-408-PSE	8" PSE Wheel Only	-
2	5/16-18 HN	5/16-18 Finished Hex Nut (zinc)	12
2	5/16-18 HN-SS	5/16-18 Finished Hex Nut (stainless steel)	12
3	5/16 LW	5/16 Lock Washer (zinc)	13
3	5/16 LW-SS	5/16 Lock Washer (stainless steel)	13
4	5/16 FW	5/16 Flat Washer (zinc)	13
4	5/16 FW-SS	5/16 Flat Washer (stainless steel)	13
5	5/16-18 X 1 HHCS	5/16-18 x 1 Hex Head Cap Screw Grade 5 (zinc)	13
5	5/16-18 X 1 HHCS-SS	5/16-18 x 1 Hex Head Cap Screw (stainless steel)	13
6	5/16-18 X 3/4 HHCS	5/16-18 x 3/4 Hex Head Cap Screw Grade 5 (zinc)	4
6	5/16-18 X 3/4 HHCS-SS	5/16-18 x 3/4 Hex Head Cap Screw (stainless steel)	4
7	2580304	SL Ergo Top Plate (Foot Pump Style)	1
8	1/2-13 x 3 3/4 HHCS	1/2-13 x 3 3/4 Hex Head Cap Screw Grade 5 (zinc)	2
8	1/2-13 x 3 3/4 HHCS-SS	1/2-13 x 3 3/4 Hex Head Cap Screw (stainless steel)	2
9	1/2 LW	1/2 Lock Washer (zinc)	2
9	1/2 LW-SS	1/2 Lock Washer (stainless steel)	2
10	1/2-13 HN	1/2-13 Finished Hex Nut (zinc)	2
10	1/2-13 HN-SS	1/2-13 Finished Hex Nut (stainless steel)	2
11	1/2-20 x 3 1/4 HHCS	1/2-20 x 3 1/4 Hex Head Cap Screw (zinc)	2
12	W-405-PSE	5" PSE Wheel Only	2
12	W-408-PSE	8" PSE Wheel Only	2
13	1/2-20 THIN NLN	1/2-20 Thin Nylon Locking Nut (Zinc)	2
14	3530145	Frame - Contact Easy Lift Equipment for Specifications	1
15	65657	Handle Grips	2
16	3530210	EL Leg Set for 5" Casters at 400lb, 600lb or 800lb capacity (Without Wheels)	1
16	3530211	EL Leg Set for 5" Casters at 600lb, 800lb or 1,000lb capacity (Without Wheels)	1
16	3530212	EL Leg Set for 8" Casters at 400lb, 600lb or 800lb capacity (Without Wheels)	1
16	3530213	EL Leg Set for 8" Casters at 600lb, 800lb or 1,000lb capacity (Without Wheels)	1
17	16LF0580	Step Down Floor Lock (for 5" wheels)	1
17	16LF0880	Step Down Floor Lock (for 8" wheels)	1
18	1" x 3" x 18-3/4" HRFB CW	1" x 3" x 18-3/4" HRFB SL Counter Weight	-
19	3530515	Counter Weight Hold-Down Flat Bar	1
20	3530516	Counter Weight Hold-Down Angle	1
21	3/8-16 x 2 HHCS	3/8-16 x 2 Hex Head Cap Screw (zinc)	1
21	3/8-16 x 2 HHCS-SS	3/8-16 x 2 Hex Head Cap Screw (stainless steel)	1
22	3/8 FW	3/8 Flat Washer (zinc)	1
22	3/8 FW-SS	3/8 Flat Washer (stainless steel)	1
23	3/8 LW	3/8 Lock Washer (zinc)	1
23	3/8 LW-SS	3/8 Lock Washer (stainless steel)	1
24	MCL007031	Specification Plate	1
25	ADART002	Attention Read Operations Manual Decal	1
26	ADART600	600lbs/272kg Capacity Sticker	1
27	ADART016	ELE Address Decal (Vertical)	2
28	ADART009	Warning 5 Degree Decal for ELE & EL	1
29	S-207	Grounding Strap	1
30	ADART055	Turn Valve Off When Not In Use To Prevent Mast From Elevating	1
31	ADART026	Air Control Up & Down Decal	1
32	6 x 1/4 RUDS-SS	6 x 1/4 Round Head U Drive Screw (stainless steel)	4
33	3530217	SL 4" Leg Set for 5" Casters up to 600lb capacity (Without Wheels)	1
33	3530218	SL 4" Leg Set for 8" Casters up to 600lb capacity (Without Wheels)	1

# PNEUMATIC MAST ASSEMBLY

## DIRECT LIFT INNER MAST

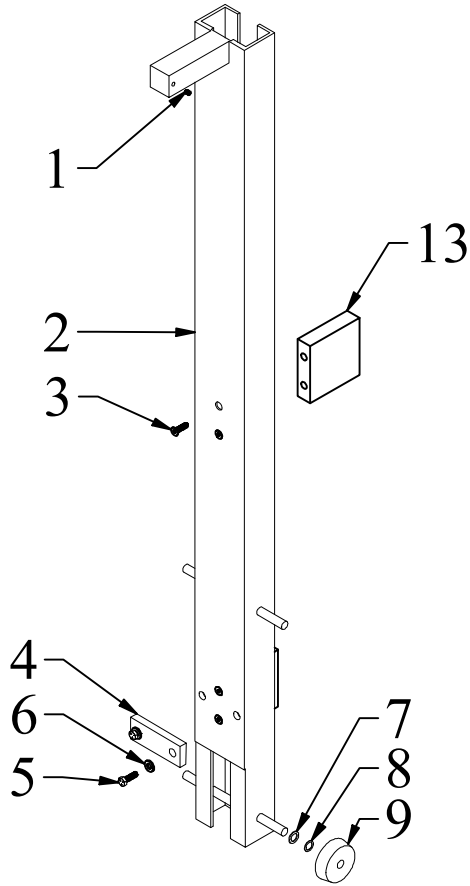

## CHAIN OVER INNER MAST

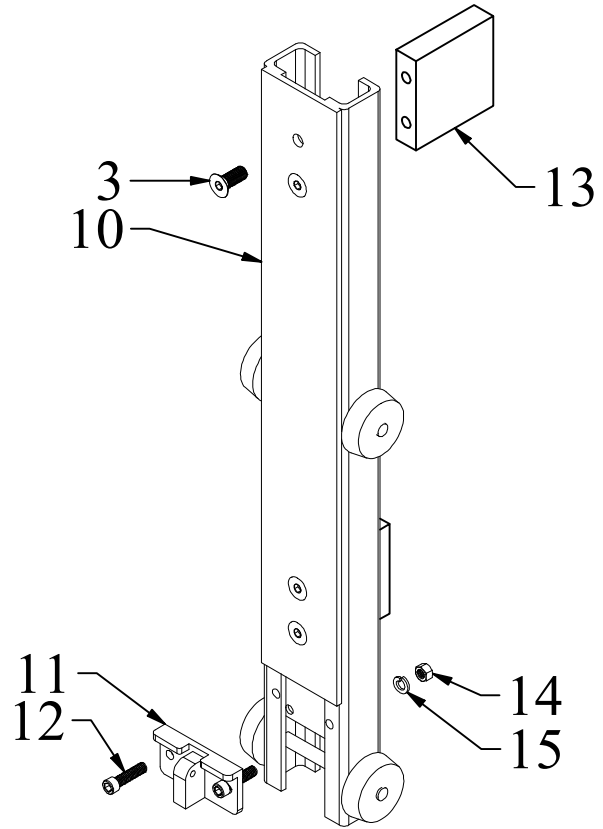

## OUTER MAST ASSEMBLY

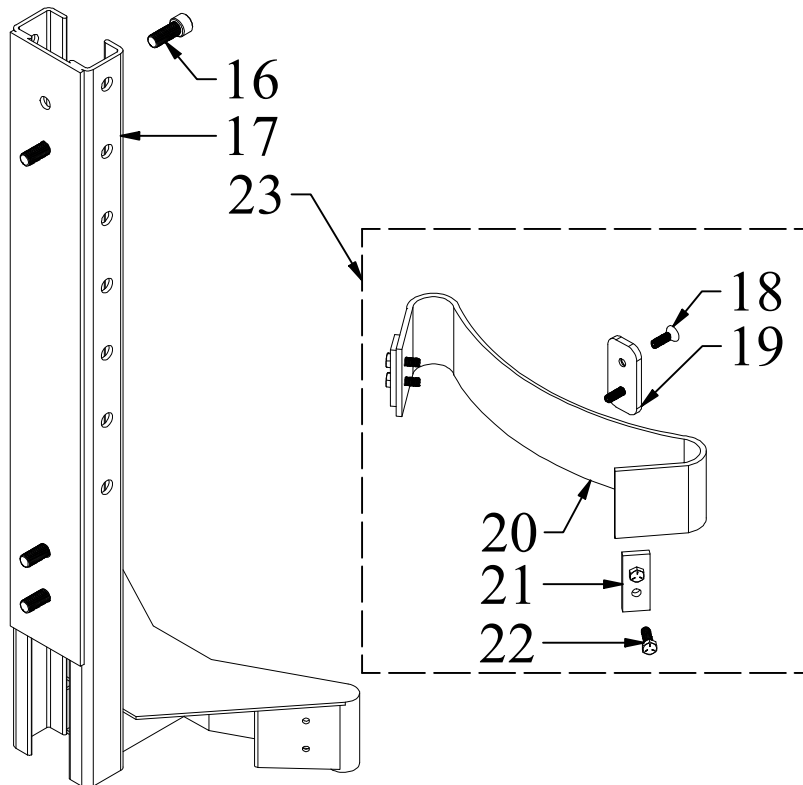

**PNEUMATIC MAST  
PARTS LIST**

**DIRECT LIFT & CHAIN OVER INNER MASTS**

<u>ITEM</u>	<u>PART NO.</u>	<u>DESCRIPTION</u>	<u>QTY</u>
1	93445A425	1/4"-20 x 3/8" Stainless Steel Knurl-Grip Set Screw	1
2	3912-A	Pneumatic Ergo Inner Mast	1
3	1/2-20 x 1 1/4 FSHCS	1/2-20 x 1 1/4 Flat Socket Head Cap Screw (zinc)	4
4	3530012	Ergo-Air Mast Stop Block	1
5	3/8-16 x 1 HHCS-8	3/8-16 x 1 Hex Head Cap Screw Grade 8 (yellow zinc)	2
6	3/8 LW	3/8 Lock Washer (zinc)	2
6	3/8 LW-SS	3/8 Lock Washer (stainless steel)	2
7	90295A187	1/16" Nylon Flat Washer	4
8	95606A170	1/32" Nylon Flat Washer	4
9	4008	Delrin Roller	4
10	2580401	32" High Inner Mast (Scale)	1
11	8912A	Pneumatic Ergo Chain-to-Mast Bracket	1
12	3/8-16 x 1 1/2 SHCS	3/8-16 x 1 1/2 Socket Head Cap Screw Alloy Plated	2
12	3/8-16 x 1 1/2 SHCS-SS	3/8-16 x 1 1/2 Socket Head Cap Screw (stainless steel)	2
13	LCRB	Load Cell Replacement Block	2
13	HM1000	Load Cell with 4' cable	2
14	3/8-16 HN	3/8-16 Finished Hex Nut (zinc)	2
14	3/8-16 HN-SS	3/8-16 Finished Hex Nut (stainless steel)	2
15	3/8 LW	3/8 Lock Washer (zinc)	2
15	3/8 LW-SS	3/8 Lock Washer (stainless steel)	2

**OUTER MAST**

<u>ITEM</u>	<u>PART NO.</u>	<u>DESCRIPTION</u>	<u>QTY</u>
16	1/2-20 x 1 1/4 SHCS	1/2-20 x 1 1/4 Socket Head Cap Screw Alloy Plated	4
17	2580453	32" High Outer Mast with 3" Belt Cradle	1
18	5/16-18 x 1 FSHCS-SS	5/16-18 x 1 Flat Socket Head Cap Screw (stainless steel)	2
19	2580051	EG1/Ergo UHMW Belt Support	1
20	5516	Rubber Belt Only (3" wide x 23" long, no hardware)	1
21	2580050	EG1/Ergo Belts Clamp Straps	2
22	5/16-18 X 1 HHCS	5/16-18 x 1 Hex Head Cap Screw Grade 5 (zinc)	4
22	5/16-18 X 1 HHCS-SS	5/16-18 x 1 Hex Head Cap Screw (stainless steel)	4
23	5516E	Optional: Belt Cradle Kit (3" wide x 23" long, includes all hardware)	1



## PNEUMATIC DIRECT LIFT 4" & 5" CYLINDER PARTS LIST

<u>ITEM</u>	<u>PART NO.</u>	<u>DESCRIPTION</u>	<u>QTY</u>
1	A14723	Air Tank	1
1	1429-4535	Air Tank (with Newfoundland & Ontario CRN Approval Use Only)	1
2	33SP1014C	1-1/2" Square Plug Black	2
3	5/16-18 x 1 HHCS-SS	5/16-18 x 1 Hex Head Cap Screw (stainless steel)	4
4	5/16 LW-SS	5/16 Lock Washer (stainless steel)	8
5	5/16 FW-SS	5/16 Flat Washer (stainless steel)	8
6	50785K68	3/4" x 1/4" Hex Reducing Bushing	2
7	50785K43	1/4" Brass 90° Elbow	1
8	4568K372	1/4" x 7" brass pipe nipple, double threaded	1
9	4912K2	Brass Ball Valve Chrome-Plated, Wedge Handle, 1/4" NPT F x M Connection	2
10	CMMQ20B	1/4" Check Valve	1
11	6534K56	1/4" Female Hex Coupler	1
12	99015K45	ASME Pop-safety valve w/test ring, brass 1/4 NPT Male 150PSI	1
13	50785K12	1/4" x 1-1/2" Brass Nipple	2
14	50785K72	1/4" Brass Tee	1
15	50785K61	1/4" x 1/8" Reducing Bushing	1
16	GRP-95-227	0-160 psi Gauge, 1/8" Center Back	1
17	NPH1/4-1/4	1/4" Tube x 1/4" NPT Elbow Fitting	3
18	1J-048-01-3	Air Line 1/4" Polyeth Black - 3' Length	1
19	NPC1/4-1/4	1/4" Tube x 1/4" NPT Straight Fitting	1
20	GAR20008SJT	Regulator with Gauge	1
21	50785K113	1/4" Brass Plug	# 2 / 1
22	9833K22	1/4" Breather Vent	# 1 / 2
23	* 4HA330C08T	3-Position Directional Valve	1
24	8-32 x 1 1/4 PTHS-SS	8-32 x 1 1/4 Phillips Truss Head Screw (stainless steel)	3
25	C40E25.005F2CCD1ERRX3.75STNS	Air Cylinder (4" Bore x 25" Stroke)	1
25	C50E25.005F2CCD1RX3.75STNS	Air Cylinder (5" Bore x 25" Stroke)	1
25	C50E25.005F2CCD1ERRX3.5SBSRSTNS	Stainless Steel Air Cylinder (5" Bore x 25" Stroke)	1
25	C50E36.005F2CCD1RX3.75	Air Cylinder (5" Bore x 36" Stroke)	1
26	5/16-18 X 1 1/4 HHCS	5/16-18 x 1 1/4 Hex Head Cap Screw Grade 5 (zinc)	4
27	1J-048-01-5	Air Line 1/4" Polyeth Black - 5' Length	1
28	813-1245-6	3/8 Steel Hydraulic Line 6"	1
29	PA80755	Steel SAE 37 (JIC) 3 pc Nut 3/8T	1
30	PA80761	Steel SAE 37 (JIC) Sleeve 3/8	1
31	9833K11	1/2" Breather Vent	1

\* Equipment with a S/N prior to G25043 will require an Air Valve Retrofit Field Install Kit (Part #: 3530555)

# First quantity is for New Style Air Valve (4HA330C08T), second quantity is for Old Style Air Valve (L22LA6520)

# PNEUMATIC AIR VALVE NEW STYLE (2025) RETROFIT FIELD INSTALL KIT PARTS LIST

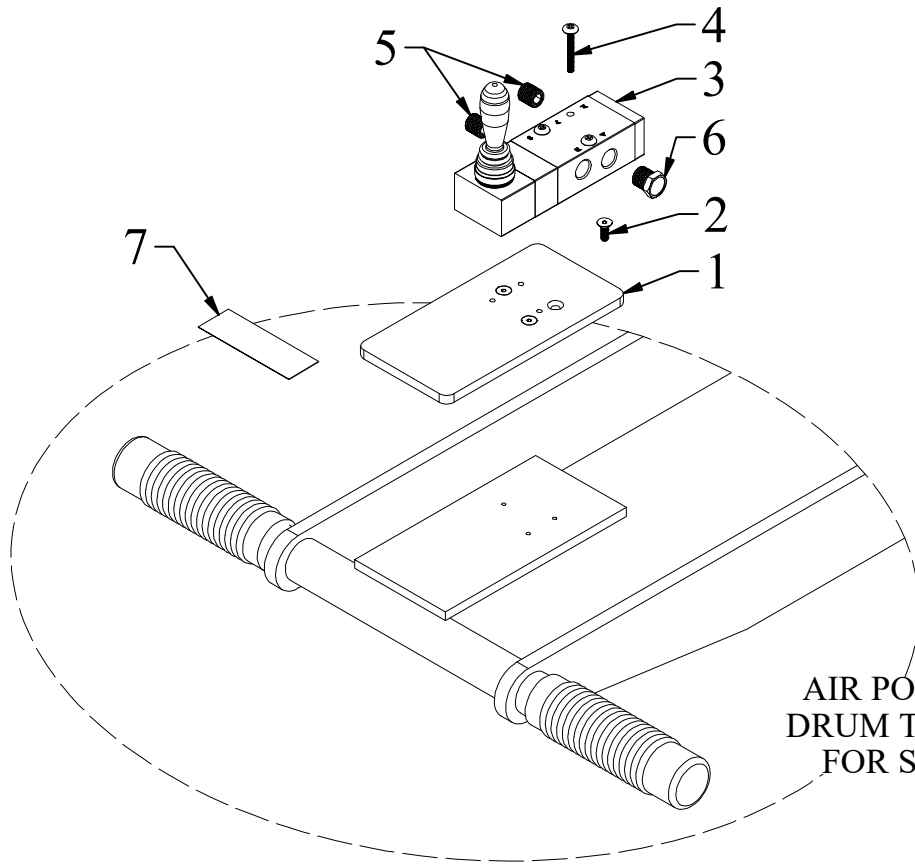

AIR POWERED ERGONOMIC  
DRUM TRANSPORTER FRAME  
FOR S/N PRIOR TO G25043

## VALVE DETAIL VIEW

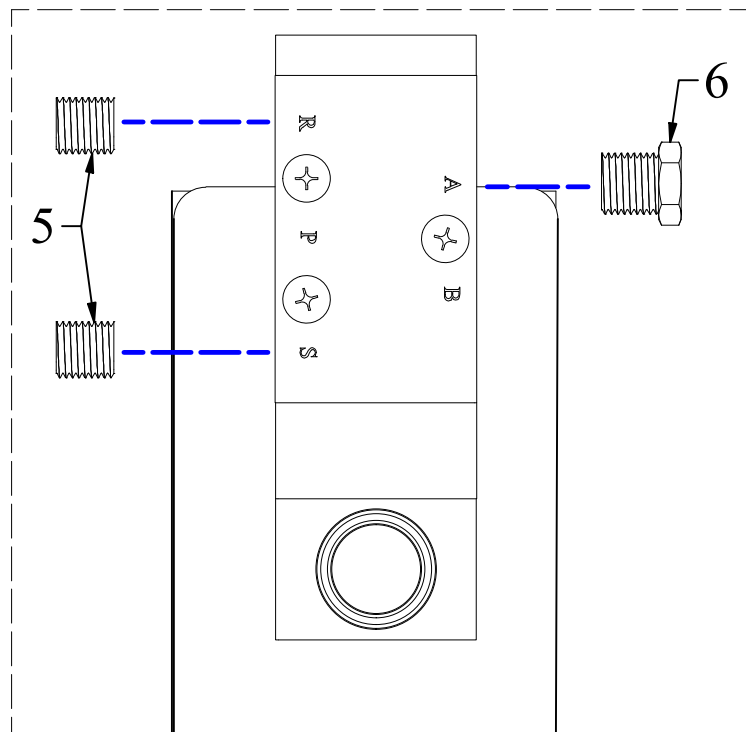

**PNEUMATIC AIR VALVE NEW STYLE (2025)  
RETROFIT FIELD INSTALL KIT  
PARTS LIST**

<u>ITEM</u>	<u>PART NO.</u>	<u>DESCRIPTION</u>	<u>QTY</u>
1	3530554	Pneumatic Air Valve New Style (2025) Retrofit Plate	1
2	8-32 x 1/2 PFHS-SS	8-32 x 1/2 Phillips Flat Head Screw (stainless steel)	3
3	4HA330C08T	3-Position Directional Valve	1
4	8-32 x 1 1/4 PTHS-SS	8-32 x 1 1/4 Phillips Truss Head Screw (stainless steel)	3
5	50785K113	1/4" Brass Plug	2
6	9833K22	1/4" Breather Vent	1
7	ADART026	Air Control Up & Down Decal	1
 <b><u>FULL KIT ASSEMBLY (Includes all the components listed above)</u></b>			
	3530555	Pneumatic Air Valve New Style (2025) Full Retrofit Field Install Kit	

# PNEUMATIC CHAIN OVER ASSEMBLY

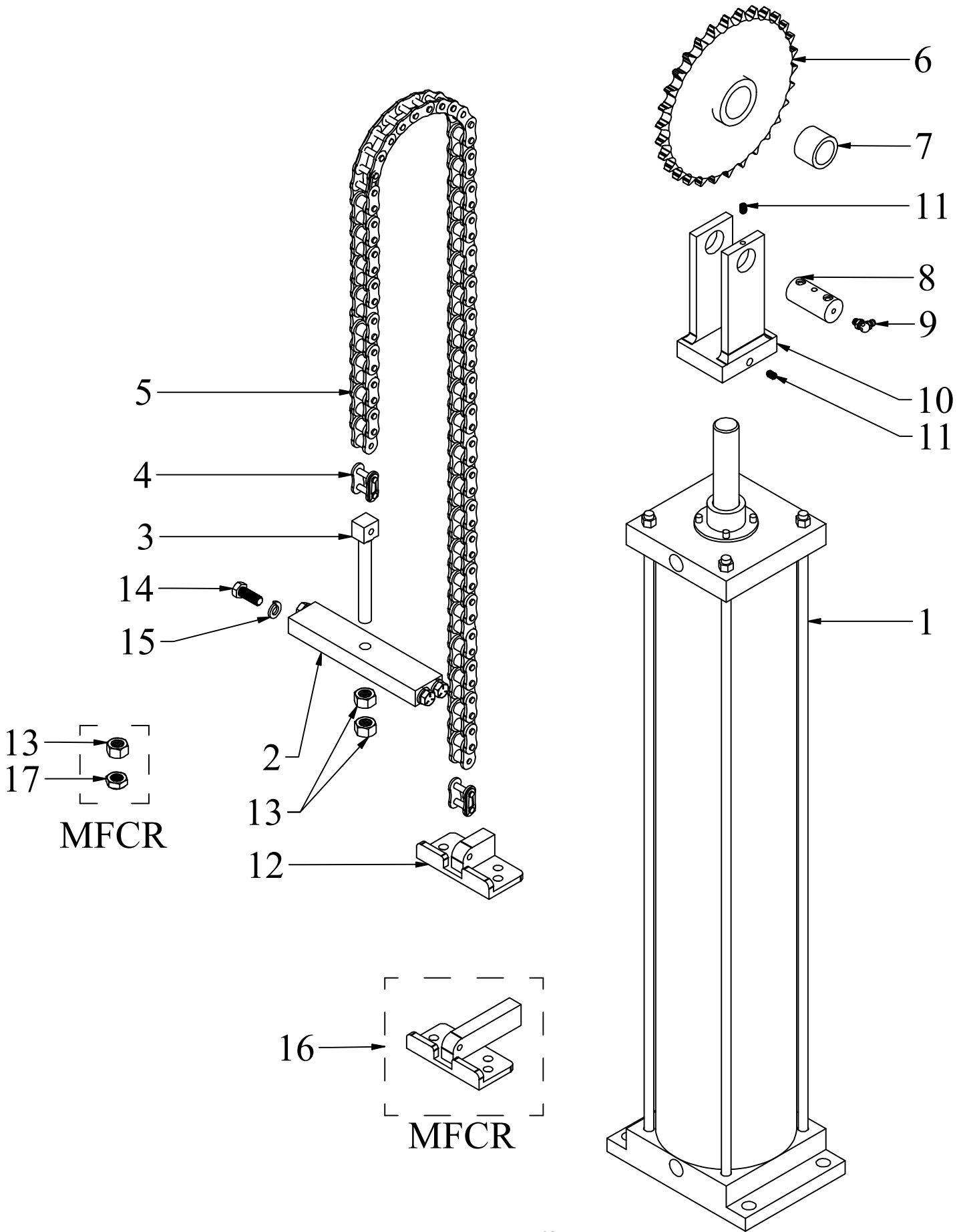

## PNEUMATIC CHAIN OVER PARTS LIST

<u>ITEM</u>	<u>PART NO.</u>	<u>DESCRIPTION</u>	<u>QTY</u>
1	C50E25.005F2CCD1RX3.75STNS	Air Cylinder (5" Bore x 25" Stroke)	1
1	C50E25.005F2CCD1ERRX3.5SBSRSTNS	Stainless Steel Air Cylinder (5" Bore x 25" Stroke)	1
1	TAC-B5454A	Air Cylinder (5" Bore x 34" Stroke) SPECIAL ORDER	1
1	C50E36.005F2CCD1RX3.75	Air Cylinder (5" Bore x 36" Stroke)	1
1	F2AT-42A4E-C7Z0	Air Cylinder (5" Bore x 42" Stroke)	1
1	C50E40.005F2CCD1RX3.75	Air Cylinder (5" Bore x 40" Stroke)	1
1	C50E45.005F2CCD1ERRX3.75STWBNS	Air Cylinder (5" Bore x 45" Stroke)	1
2	3530013	Chain Mount Ergo-A	1
3	2022	Chain Adjuster for ANSI 60 Chain	1
4	60HMCL	ANSI 60 Link	1
4	60PCP2CL	FDA ANSI 60 Link	1
5	RC060RC1-90	Chain-Ansi 60 for Ergo Air (90" Long)	1
5	RC060RC1-90PC	FDA Chain-Ansi 60 for Ergo Air (90" Long)	1
6	7912-A	Lift Sprocket Bracket Air Cylinder Ergo	1
7	CB-1622-08	Sheave Wheel Bushing	1
8	45061	Sheave Wheel Axle (1" x 2.125")	1
9	1095K93	Zinc Plated Steel Grease Fitting, 90° Elbow, 1/4"-28 SAE-LT Male 51/64" L	1
10	3530014	Sheave Sprocket Bracket Ergo-A	1
11	93445A425	1/4"-20 x 3/8" Stainless Steel Knurl-Grip Set Screw	2
12	8912A	Pneumatic Ergo Chain-to-Mast Bracket	1
13	1/2-13 HN	1/2-13 Finished Hex Nut (zinc)	3
14	3/8-16 x 1 1/4 HHCS-8	3/8-16 x 1 1/4 Hex Head Cap Screw Grade 8 (yellow zinc)	4
14	3/8-16 x 1 1/4 HHCS-SS	3/8-16 x 1 1/4 Hex Head Cap Screw (stainless steel)	4
15	3/8 LW	3/8 Lock Washer (zinc)	4
15	3/8 LW-SS	3/8 Lock Washer (stainless steel)	4
16	8912AMFCR	Pneumatic MFCR Chain-to-Mast Bracket (Delrin Rollers)	1
17	1/2-13 NLN	1/2-13 Nylon Locking Nut (zinc)	1

# EG1 LIGHT DUTY SINGLE CLAMPING MECHANISM ASSEMBLY

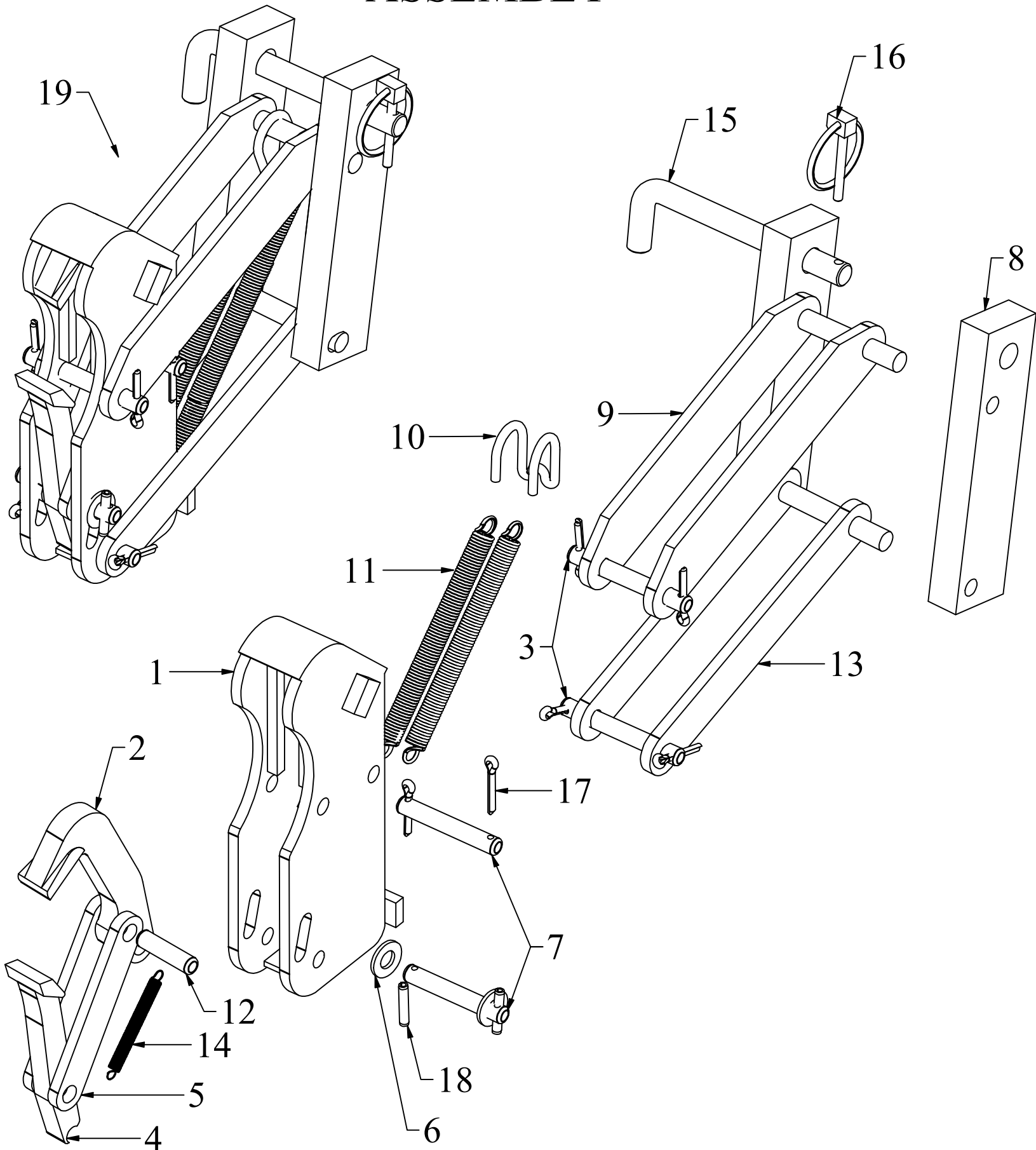

## EG1 LIGHT DUTY SINGLE CLAMPING MECHANISM PARTS LIST

<u>ITEM</u>	<u>PART NO.</u>	<u>DESCRIPTION</u>	<u>QTY</u>
1	6302	Housing (Black Powder Coating)	1
1	6302SS	Housing (Stainless Steel)	1
2	9107SS	Stainless Steel Upper Jaw (Spark Resistant)	1
3	15104-1SS	3/8" x 2.242" Pin, Fibre Guard, Housing to Clevis (stainless steel)	2
4	7107SS	Stainless Steel Lower Jaw (Spark Resistant)	1
5	13009-1	Link, Jaw to Jaw (zinc)	2
5	13009-1SS	Link, Jaw to Jaw (stainless steel)	2
6	C616 FW-SS	C616 Flat Washer (stainless steel)	2
7	16104-1SS	3/8" x 1.770" Pin, Upper Jaw Link (stainless steel)	2
8	8002	Adjustment Slide (FDA Black Powder Coating)	2
8	8002SS	Adjustment Slide (Stainless Steel)	2
9	5912	Upper Clevis 8" (FDA Black Powder Coating - 5" Belt Cradle)	1
9	5912SS	Upper Clevis 8" (Stainless Steel - 5" Belt Cradle)	1
9	5912S	Upper Clevis 6" (FDA Black Powder Coating - 3" Belt Cradle)	1
9	5912SS-S	Upper Clevis 6" (Stainless Steel - 3" Belt Cradle)	1
10	8996-2	Clevis Spring Hook (Stainless Steel)	1
11	8206	Clevis Spring (zinc)	2
12	41041SS	3/8" x 1" Pin, Upper Jaw to Link, short (stainless steel)	1
13	6912	Lower Clevis 7 1/2" (FDA Black Powder Coating - 5" Belt Cradle)	1
13	6912SS	Lower Clevis 7 1/2" (Stainless Steel - 5" Belt Cradle)	1
13	6912S	Lower Clevis 5 1/2" (FDA Black Powder Coating - 3" Belt Cradle)	1
13	6912SS-S	Lower Clevis 5 1/2" (Stainless Steel - 3" Belt Cradle)	1
14	1206	Spring, Jaw to Housing (stainless steel)	1
15	10204-1SS	1/2" x 4-1/2" Adjusting Pin (stainless steel)	1
16	HANG-1	3/16 x 1-1/4 Shank Lynch Pin "Hang 1" (9016)	1
16	HANG-1SS	3/16 x 1-1/4 Shank Lynch Pin "Hang 1" Stainless Steel	1
17	3006-CP	Cotter Pin, 1/8" x 3/4" (zinc)	6
17	1/8 x 3/4 CP-SS	1/8 x 3/4 Cotter Pins (stainless steel)	6
18	5/32 x 1/2 Roll Pin	Stainless Steel 5/32 x 1/2 Roll Pin	2
	B-800	White Lithium Grease Can	1
<b><u>FULL ASSEMBLIES</u></b>			
19	9004	EG1 Single Clamping Mechanism (FDA Black Powder Coating - 5" Belt Cradle)	
19	9004S	EG1 Single Clamping Mechanism (FDA Black Powder Coating - 3" Belt Cradle)	
19	9004SRC	EG1 Single Clamping Mechanism (Stainless Steel Housing - Spark Resistant - 5" Belt Cradle)	
19	9004SRC-S	EG1 Single Clamping Mechanism (Stainless Steel Housing - Spark Resistant - 3" Belt Cradle)	
19	9004SS	EG1 Single Clamping Mechanism (FULL Stainless Steel - Spark Resistant - 5" Belt Cradle)	
19	9004SS-S	EG1 Single Clamping Mechanism (FULL Stainless Steel - Spark Resistant - 3" Belt Cradle)	
<b><u>PREVENTATIVE MAINTENANCE KITS</u></b>			
	EG1PMKIT	EG1 Preventative Maintenance Kit	
	EG1BCPMKIT	EG1 Preventative Maintenance Kit w/ Belt Cradle	

**EG1 SINGLE CLAMPING MECHANISM  
PREVENTATIVE MAINTENANCE KIT BREAKDOWN**

**EG1PMKIT - EG1 PREVENTATIVE MAINTENANCE KIT**

<u>ITEM</u>	<u>PART NO.</u>	<u>DESCRIPTION</u>	<u>QTY</u>
11	8206	Clevis Spring (zinc)	2
14	1206	Spring, Jaw to Housing (stainless steel)	1
16	HANG-1	3/16 x 1-1/4 Shank Lynch Pin "Hang 1" (9016)	1
17	3006-CP	Cotter Pin, 1/8" x 3/4" (zinc)	6
18	5/32 x 1/2 Roll Pin	Stainless Steel 5/32 x 1/2 Roll Pin	2
	B-800	White Lithium Grease Can	1

**EG1BCPMKIT - EG1 PREVENTATIVE MAINTENANCE WITH BELT CRADLE KIT**

<u>PART NO.</u>	<u>DESCRIPTION</u>	<u>QTY</u>
11	8206	Clevis Spring (zinc)
13	5516E	Optional: Belt Cradle Kit (3" wide x 23" long, includes all hardware)
14	1206	Spring, Jaw to Housing (stainless steel)
16	HANG-1	3/16 x 1-1/4 Shank Lynch Pin "Hang 1" (9016)
17	3006-CP	Cotter Pin, 1/8" x 3/4" (zinc)
18	5/32 x 1/2 Roll Pin	Stainless Steel 5/32 x 1/2 Roll Pin
	B-800	White Lithium Grease Can

**EG1SRCPMKIT - EG1 PREVENTATIVE MAINTENANCE KIT**

<u>ITEM</u>	<u>PART NO.</u>	<u>DESCRIPTION</u>	<u>QTY</u>
11	8206	Clevis Spring (zinc)	2
13	5516E	Optional: Belt Cradle Kit (3" wide x 23" long, includes all hardware)	1
14	1206	Spring, Jaw to Housing (stainless steel)	1
16	HANG-1SS	3/16 x 1-1/4 Shank Lynch Pin "Hang 1" Stainless Steel	1
17	1/8 x 3/4 CP-SS	1/8 x 3/4 Cotter Pins (stainless steel)	6
18	5/32 x 1/2 Roll Pin	Stainless Steel 5/32 x 1/2 Roll Pin	2
	B-800	White Lithium Grease Can	1

**THIS PAGE INTENTIONALLY LEFT BLANK**

# EAGLE-GRIP 1 MAUSER CLAMPING MECHANISM ASSEMBLY

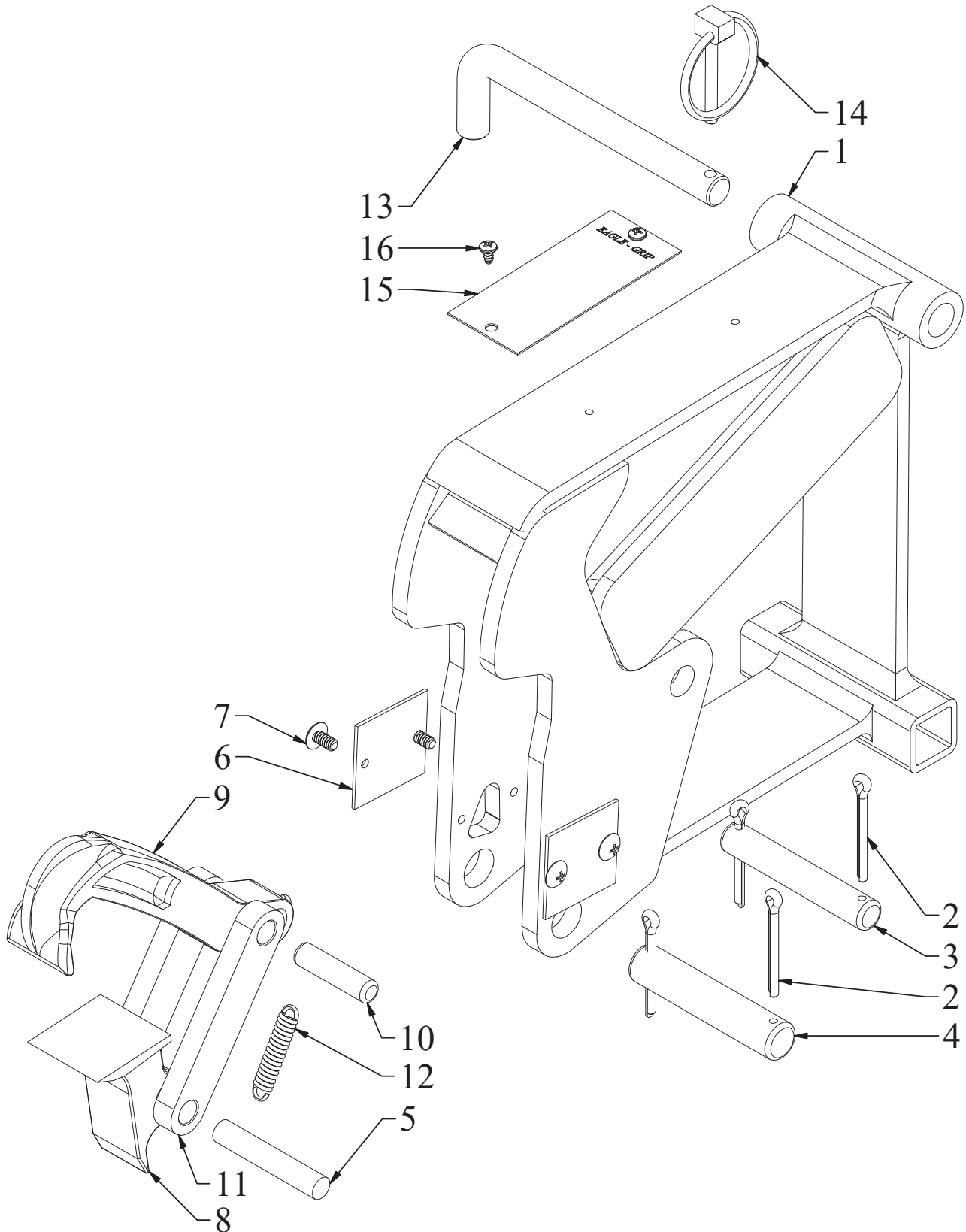

## EAGLE-GRIP 1 MAUSER CLAMPING MECHANISM PARTS LIST

<u>ITEM</u>	<u>PART NO.</u>	<u>DESCRIPTION</u>	<u>QTY</u>
1	7902M3	Mauser Housing for 3" Cradle (Black Powder Coating)	1
1	7902M5	Mauser Housing for 5" Cradle (Black Powder Coating)	1
2	6006-CP	Cotter Pin, 5/32" x 1" (zinc)	4
3	16033-1	1/2" x 2.625" Pin, Clevis (zinc)	1
4	3530067	5/8" x 2-7/8" 316 Stainless Steel Pin	1
5	62041	3/8" x 2.13" Pin, Link to Lower Jaw (zinc)	1
6	TSRBS .0625	1 1/2 x 1 1/2 Shim .0625 (1/16")	2
7	10-24 X 3/8 BSC-SS	10-24 x 3/8 Button Socket Cap 18/8 (stainless steel)	4
8	5107M	Mauser Lower Clamp Jaw (Black Powder Coating)	1
9	1007M	Mauser Upper Clamp Jaw (Black Powder Coating)	1
10	72041	3/8" x 1-1/2" Pin, Link to Upper Jaw (zinc)	1
11	70091	Link, Jaw to Jaw	2
12	4306	Jaw Spring (zinc)	1
13	10204-1SS	1/2" x 4-1/2" Adjusting Pin (stainless steel)	1
14	HANG-1	3/16 x 1-1/4 Shank Lynch Pin "Hang 1" (9016)	1
15	MCL044991	PM Tag	1
16	6 x 1/4 RUDS-SS	6 x 1/4 Round Head U Drive Screw (stainless steel)	2
 <b><u>FULL ASSEMBLIES</u></b>			
17	9004M3	EG1 Mauser Clamping Mechanism for 3" Cradle (Black Powder Coating)	
17	9004M5	EG1 Mauser Clamping Mechanism for 5" Cradle (Black Powder Coating)	

# EG2 LIGHT DUTY DOUBLE CLAMPING MECHANISM ASSEMBLY

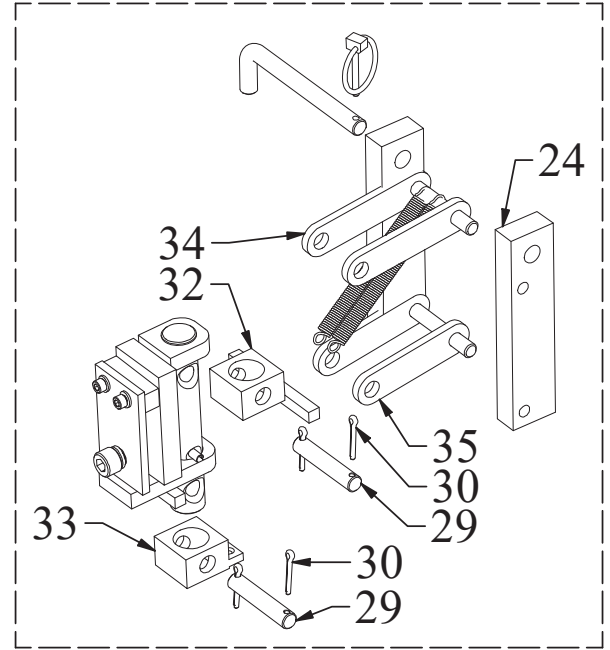
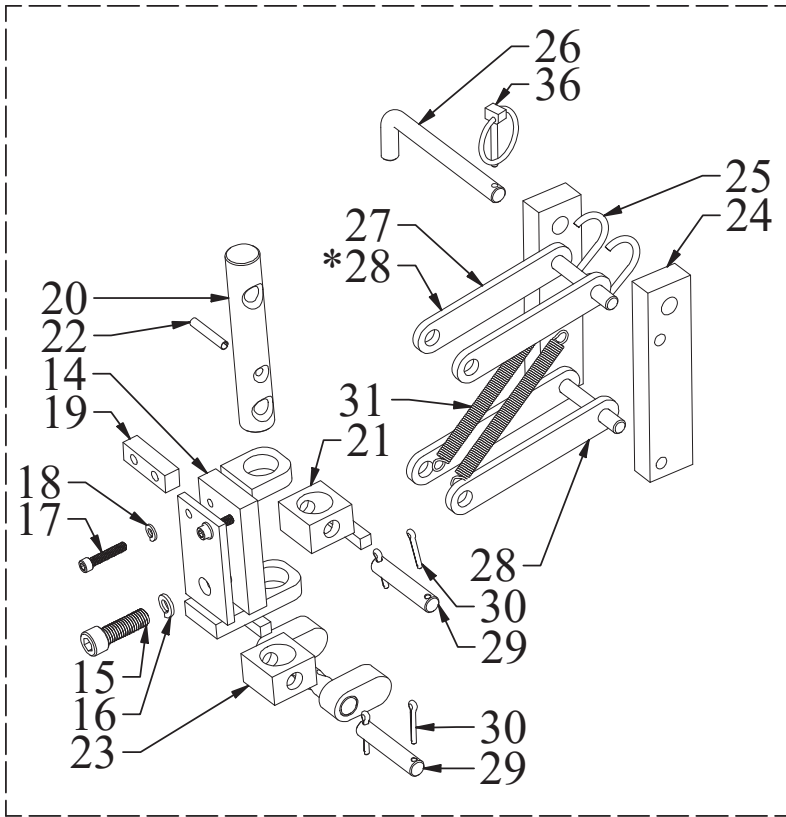

SEEN ON LEFT: **ERGO UNITS WITH A 5" BELT CRADLE** WILL PRIMARILY USE A 6" UPPER CLEVIS (#27) AND A 5-1/2" LOWER CLEVIS (#28). ALONG WITH A LOWER PIVOT BLOCK WITH OVAL STOP BARS (#23) AND AN UPPER PIVOT BLOCK WITH A 2-1/4" STOP BAR (#21).

**\*EAGLE-GRIP ATTACHMENTS** WILL PRIMARILY USE 5-1/2" LOWER CLEVISES (#28) FOR BOTH THE TOP AND BOTTOM CLEVISES.

SEEN ON THE RIGHT: **ERGO UNITS WITH A 3" BELT CRADLE** WILL PRIMARILY USE A 4-1/2" UPPER CLEVIS (#34) AND A 4" LOWER CLEVIS (#35). ALONG WITH A LOWER PIVOT BLOCK (#33) AND AN UPPER PIVOT BLOCK WITH A 3-3/4" STOP BAR (#32).

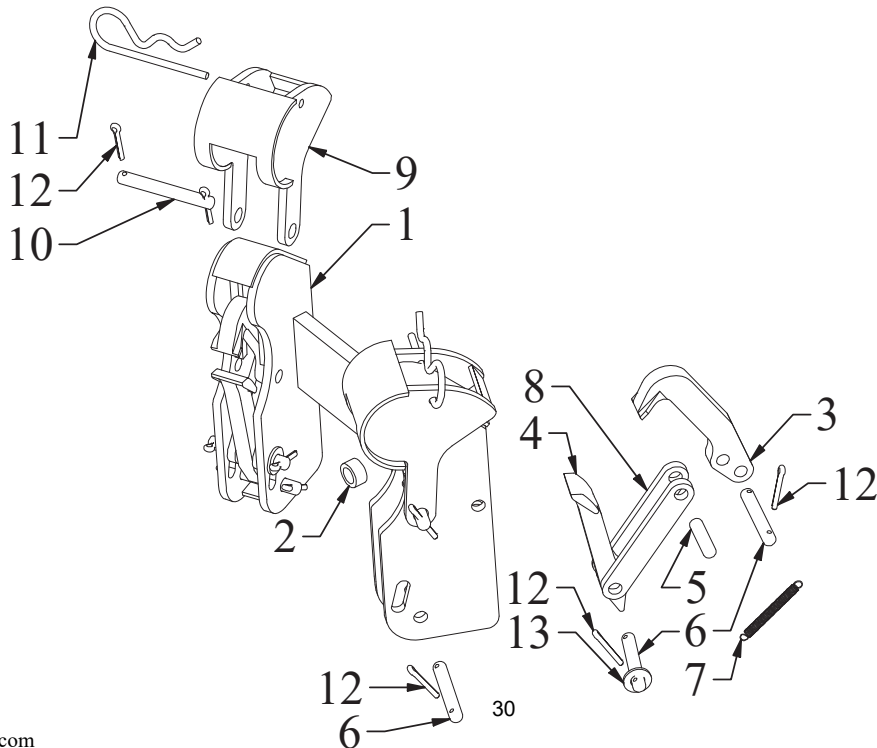

**EG2 LIGHT DUTY DOUBLE CLAMPING MECHANISM  
PARTS LIST**

<u>ITEM</u>	<u>PART NO.</u>	<u>DESCRIPTION</u>	<u>QTY</u>
1	7302R	Housing, Double Clamping Mechanism (Black Powder Coating)	1
1	7302RSS	Housing, Double Clamping Mechanism (Stainless Steel)	1
2	10001	Bushing, Housing Yolk Trunion (zinc)	1
3	9107SS	Stainless Steel Upper Jaw (Spark Resistant)	2
4	7107SS	Stainless Steel Lower Jaw (Spark Resistant)	2
5	41041SS	3/8" x 1" Pin, Upper Jaw to Link, short (stainless steel)	2
6	16104-1SS	3/8" x 1.770" Pin, Upper Jaw Link (stainless steel)	6
7	1206	Spring, Jaw to Housing (stainless steel)	2
8	13009-1	Link, Jaw to Jaw (zinc)	4
8	13009-1SS	Link, Jaw to Jaw (stainless steel)	4
9	621	Fiber Drum Guard (Black Powder Coating)	2
9	621SS	Fiber Drum Guard (Stainless Steel)	2
10	15104-1SS	3/8" x 2.242" Pin, Fibre Guard, Housing to Clevis (stainless steel)	2
11	7019	3-7/8" Hair Pin Clip (zinc)	2
11	92391A210	18-8 Stainless Steel Cotter Pin, 18-8, Fits 7/8"-1", 3-3/4"	2
12	3006-CP	Cotter Pin, 1/8" x 3/4" (zinc)	16
12	1/8 x 3/4 CP-SS	1/8 x 3/4 Cotter Pins (stainless steel)	16
13	C616 FW-SS	C616 Flat Washer (stainless steel)	4
14	6012R	Universal Body (Black Powder Coating)	1
15	1/2-13 x 1 1/2 SHCS	1/2-13 x 1 1/2 Socket Head Cap Screw (zinc)	1
15	1/2-13 x 1 1/2 SHCS-SS	1/2-13 x 1 1/2 Socket Head Cap Screw (Stainless Steel)	1
16	1/2 LW	1/2 Lock Washer (zinc)	1
16	1/2 LW-SS	1/2 Lock Washer (stainless steel)	1
17	1/4-20 x 1 1/4 SHCS	1/4-20 x 1 1/4 Socket Head Cap Screw Alloy Plated	2
17	1/4-20 x 1 1/4 SHCS-SS	1/4-20 x 1 1/4 Socket Head Cap Screw (stainless steel)	2
18	1/4 LW	1/4 Lock Washer (zinc)	2
18	1/4 LW-SS	1/4 Lock Washer (stainless steel)	2
19	50064	Spacer (Black Powder Coating)	1
20	64061	Universal Pin (zinc)	1
20	64061-SS	Universal Pin (Stainless Steel)	1
21	50021R	Upper Pivot Block (Black Powder Coating - 5" Belt Cradle)	1
22	70062	Spring Roll Pins 1/4 X1-1/2 (zinc) (xref 70641)	1
22	1/4 x 1-1/2 SP-SS	1/4" x 1-1/2" Stainless Steel Spring Roll Pin	1
23	5012R	Lower Pivot Block with Oval Stop Bars (Black Powder Coating - 5" Belt Cradle)	1
24	8002	Adjustment Slide (FDA Black Powder Coating)	2
25	8996-2	Clevis Spring Hook (Stainless Steel)	1
26	10204-1SS	1/2" x 4-1/2" Adjusting Pin (stainless steel)	1
27	5912R	Upper Clevis 6" (Black Powder Coating - 5" Belt Cradle)	1
27	5912RZ	Upper Clevis 6" (FDA Powder Coating - 5" Belt Cradle)	1
28	6912R	Lower Clevis 5 1/2" (Black Powder Coating - 5" Belt Cradle)	1
28	6912RZ	Lower Clevis 5 1/2" (FDA Powder Coating - 5" Belt Cradle)	1
29	16033-1	1/2" x 2.625" Pin, Clevis (zinc)	2
29	EL-5-3SSH	1/2" x 3" Stainless Steel Pin - with cotter pin holes	2
30	6006-CP	Cotter Pin, 5/32" x 1" (zinc)	4
30	5/32 x 1 CP-SS	5/32 x 1 Cotter Pins (Stainless Steel)	4
31	8206	Clevis Spring (zinc)	2
32	50021RS	Upper Pivot Block (Black Powder Coating - 3" Belt Cradle)	1
33	5012RS	Lower Pivot Block (Black Powder Coat- 3" Belt Cradle)	1
34	5912RS	Upper Clevis 4 7/16" (Black Powder Coating - 3" Belt Cradle)	1
34	5912RZS	Upper Clevis 4 7/16" (FDA Powder Coating - 3" Belt Cradle)	1
35	6912RS	Lower Clevis 4" (Black Powder Coating - 3" Belt Cradle)	1
35	6912RZS	Lower Clevis 4" (FDA Powder Coating - 3" Belt Cradle)	1
36	HANG-1	3/16 x 1-1/4 Shank Lynch Pin "Hang 1" (9016)	1
36	HANG-1SS	3/16 x 1-1/4 Shank Lynch Pin "Hang 1" Stainless Steel	1

**FULL ASSEMBLIES**

4004R	EG2L Double Clamping Mechanism (Black Powder Coating - 5" Belt Cradle)
4004RS	EG2L Double Clamping Mechanism (Black Powder Coating - 3" Belt Cradle)
4004RSRC	EG2L Double Clamping Mechanism (Stainless Steel Housing - Spark Resistant - 5" Belt Cradle)
4004RSRC-S	EG2L Double Clamping Mechanism (Stainless Steel Housing - Spark Resistant - 3" Belt Cradle)
4004SS	EG2L Double Clamping Mechanism (FULL Stainless Steel - Spark Resistant - 5" Belt Cradle)
4004SS-S	EG2L Double Clamping Mechanism (FULL Stainless Steel - Spark Resistant - 3" Belt Cradle)

**PREVENTATIVE MAINTENANCE KITS**

EG2LPMKIT	EG2LDCM Preventative Maintenance Kit
EG2LSRCPMKIT	EG2LDCMSRC Preventative Maintenance Kit

**EG2 LIGHT DUTY DOUBLE CLAMPING MECHANISM  
PREVENTIVE MAINTENANCE KIT PARTS LIST**

**EG2LPMKIT - EG2L PREVENTATIVE MAINTENANCE KIT**

<u>ITEM</u>	<u>PART NO.</u>	<u>DESCRIPTION</u>	<u>QTY</u>
7	1206	Spring, Jaw to Housing (stainless steel)	2
11	7019	3-7/8" Hair Pin Clip (zinc)	2
12	3006-CP	Cotter Pin, 1/8" x 3/4" (zinc)	16
31	8206	Clevis Spring (zinc)	2
36	HANG-1	3/16 x 1-1/4 Shank Lynch Pin "Hang 1" (9016)	1
-	5516E	Optional: Belt Cradle Kit (3" wide x 23" long, includes all hardware)	1
-	B-800	White Lithium Grease Can	1

**EG2LSRCPMKIT - EG2LSRC PREVENTATIVE MAINTENANCE KIT**

	<u>PART NO.</u>	<u>DESCRIPTION</u>	<u>QTY</u>
7	1206	Spring, Jaw to Housing (stainless steel)	2
11	92391A210	18-8 Stainless Steel Cotter Pin, 18-8, Fits 7/8"-1", 3-3/4"	2
12	1/8 x 3/4 CP-SS	1/8 x 3/4 Cotter Pins (stainless steel)	16
31	8206	Clevis Spring (zinc)	2
36	HANG-1SS	3/16 x 1-1/4 Shank Lynch Pin "Hang 1" Stainless Steel	1
-	5516E	Optional: Belt Cradle Kit (3" wide x 23" long, includes all hardware)	1
-	B-800	White Lithium Grease Can	1

THIS PAGE INTENTIONALLY LEFT BLANK

# SCALE HARDWARE & WIRING FOR ERGO & EAGLE-GRIP STYLE MASTS ASSEMBLY

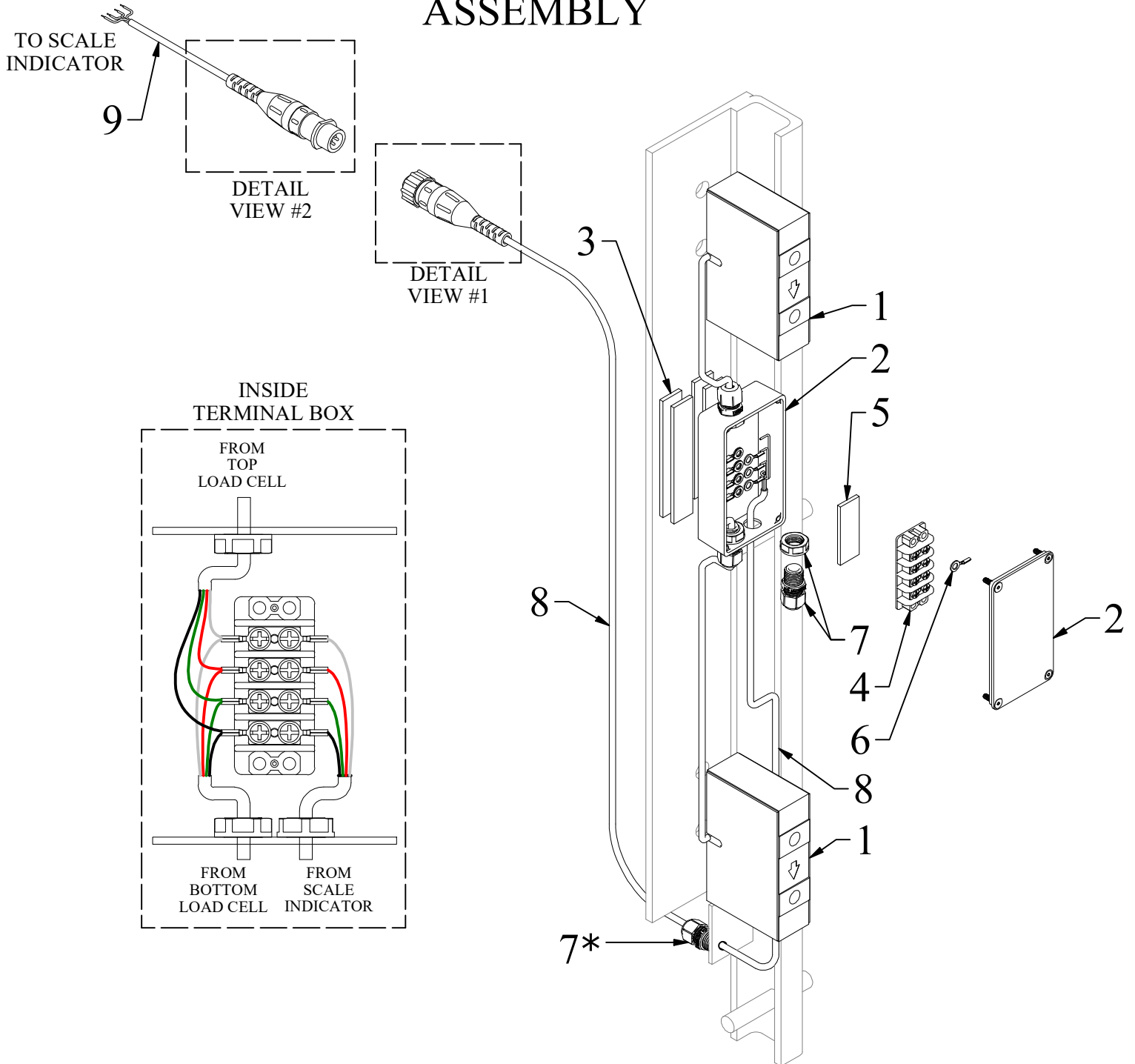

DETAIL VIEW #1 (MACHINE SIDE)

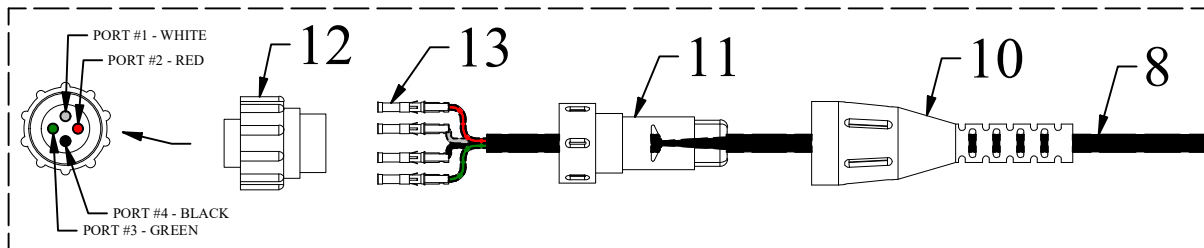

DETAIL VIEW #2 (SCALE SIDE)

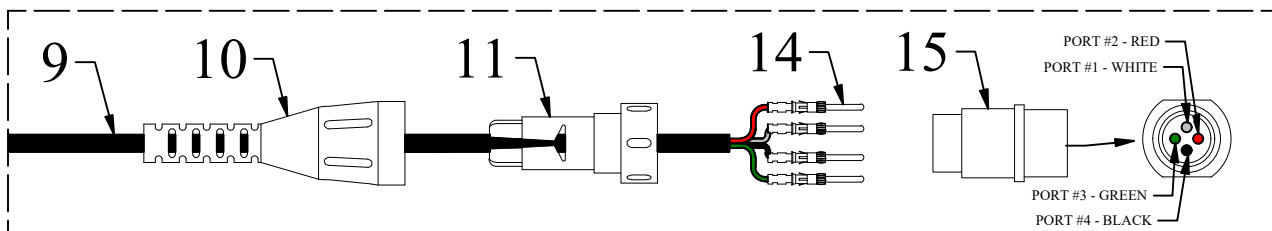

**SCALE HARDWARE & WIRING  
FOR ERGO AND EAGLE-GRIP MASTS  
PARTS LIST**

<b><u>ITEM</u></b>	<b><u>PART NO.</u></b>	<b><u>DESCRIPTION</u></b>	<b><u>QTY</u></b>
1	HM1000	Load Cell with 4' cable	2
2	CU-124	Terminal Box Enclosure	1
3	75315A34-4	Foam Tape, 2 sided adhesive, 3/4" X .125" x 4" length	4
4	7527K64	Terminal Block (Strip) 7/16", 4 circuits	1
5	75315A34-2	Foam Tape, 2 sided adhesive, 3/4" X .125" x 2" length	1
6	3A214	Terminal Eyelet	12
7	ZZHEY3208	Cable Fitting	4
8	3530359	Ergo Scale Cable Assembly (Female End) - 60" Length	1
8	3530360	Eagle-Grip Scale Cable Assembly (Female End) - 30" Length	1
9	3530361	Eagle-Grip/Ergo Scale Cable Assembly (Male End) - 24" Length	1
10	AP2074891	Strain Relief	2
11	AP2074901	Cable Grip	2
12	AP2060601	Connector Plug Size 11-4 (Female)	1
13	AP661054	Terminal Socket	4
14	AP661034	Terminal Pin	4
15	AP2061531	Connector Recp CPC 11-4 (Male)	1

\* Modified Strain Relief

**Non-Intrinsically Safe Indicators**

7000XLM	Doran® 7000XL Non-intrinsically Safe Scale Indicator
SUB0853	Rechargeable Battery, with wire and terminals (2200, 7000, 8000)
2200	Doran® 2200 Non-intrinsically Safe Scale Indicator (Numeric Keypad)
EXOPT319	Battery Option for Non-Intrinsically Safe 2200 Indicator
164582	Rice Lake®482 Indicator w Internal Battery & Charger
164585	Rice Lake®482 Plus Indicator w Internal Battery & Charger
107708	Rice Lake®720i Indicator

**Intrinsically Safe Indicators**

185288	Rice Lake®882IS Indicator w Battery Pack & Safe Area Charger
185291	Rice Lake®882IS PLUS Indicator w Battery Pack & Safe Area Charger
180831	Rice Lake®882IS Battery
194191	Rice Lake®882IS Battery Charger (IS6V2, 100-240 VAC)
72210052	Mettler Toledo IND226x Indicator ONLY
72258718	Mettler Toledo IND560x Indicator ONLY
64060627	Mettler Toledo EX Indicator Battery (Includes Cable)
64060217	Mettler Toledo Battery Charger (Safe Area, US Plug)

# EAGLE-GRIP, EL & MFCR SCALE BRACKET ASSEMBLY

## EL & MFCR SWIVEL BRACKET

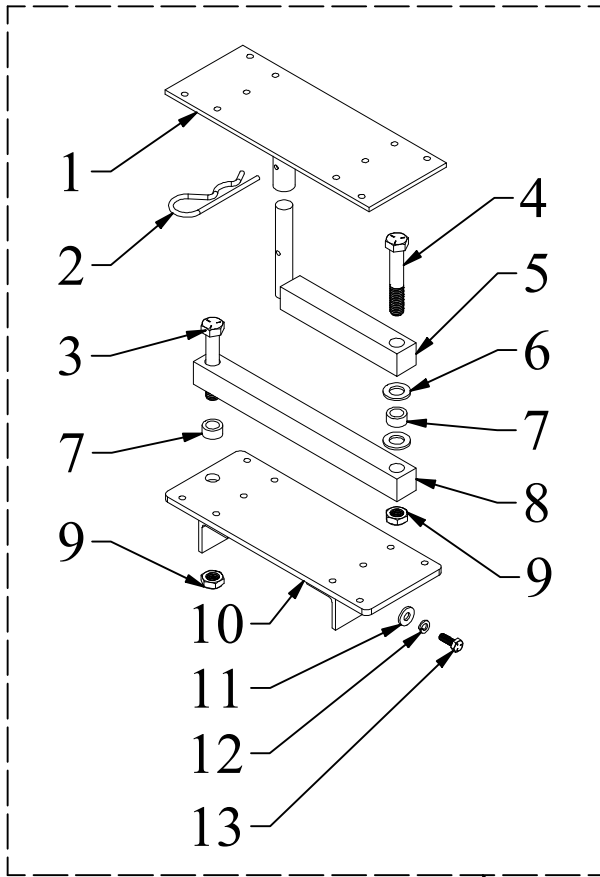

## EL ELEVATED RISER

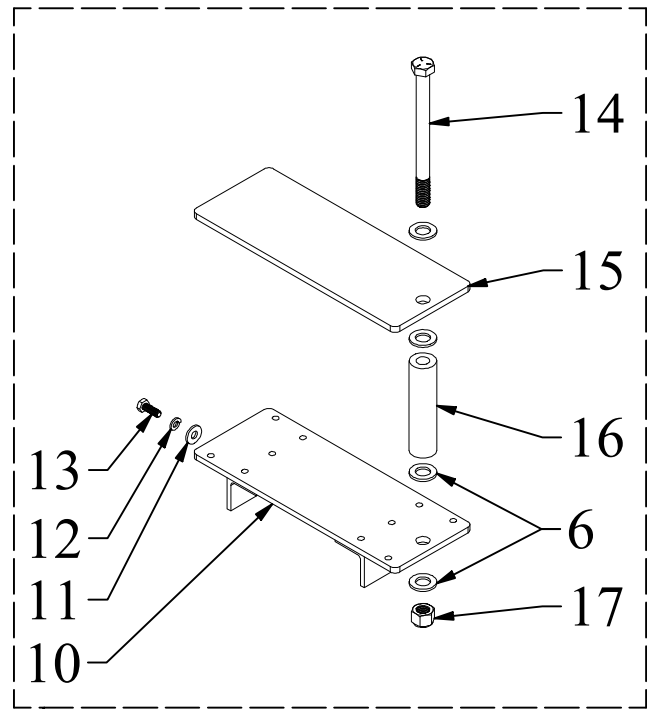

## EAGLE-GRIP SWIVEL BRACKET

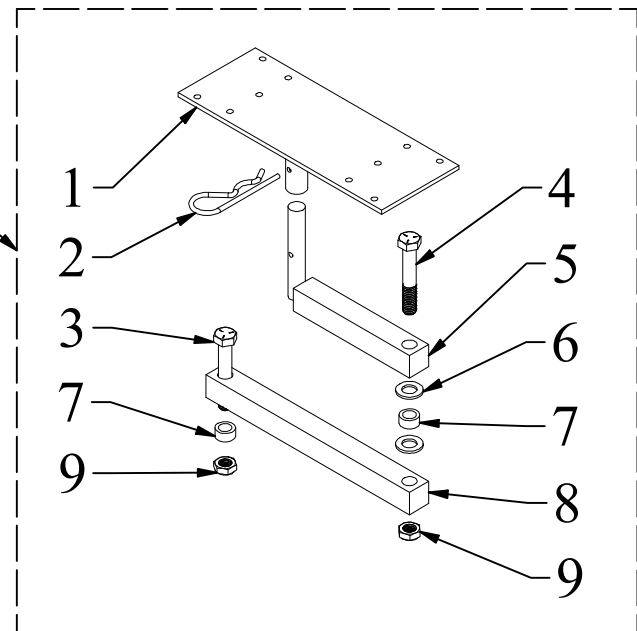

18  
19  
20

**EAGLE-GRIP, EL & MFCR  
SCALE BRACKET  
PARTS LIST**

<b><u>ITEM</u></b>	<b><u>PART NO.</u></b>	<b><u>DESCRIPTION</u></b>	<b><u>QTY</u></b>
1	3530348	Indicator Mount Bracket With Tube	1
2	98335A094	Zinc-plated steel cotter pin, 7/8"-1 D, 3-3/4 L	2
3	1/2-13 x 2 1/2 HHCS	1/2-13 x 2 1/2 Hex Head Cap Screw Grade 5 (zinc)	2
4	1/2-13 x 3 HHCS	1/2-13 x 3 Hex Head Cap Screw Grade 5 (zinc)	2
5	2580309	Scale Swing Bracket Post Bracket	2
6	1/2 FW	1/2 Flat Washer (zinc)	8
7	10001	Bushing, Housing Yolk Trunion (zinc)	4
8	2580308	Scale Swing Bracket Mid Bracket	2
9	1/2-13 THIN NLN	1/2-13 Nylon Locking Nut (THIN ZINC)	4
10	2580306	Ergo Scale Mount - 1.5" High	2
10	3530396	Ergo Scale Mount - 6.5" High	2
11	1/4 FW SAE	1/4 Flat Washer SAE (zinc)	4
12	1/4 LW	1/4 Lock Washer (zinc)	4
13	1/4-20 x 3/4 HHCS	1/4-20 x 3/4 Hex Head Cap Screw Grade 5 (zinc)	4
14	1/2-13 x 6 HHCS	1/2-13 x 6 Hex Head Cap Screw Grade 5 (zinc)	1
15	3530445	Elevated Scale Plate	1
16	3530446	Elevated Scale Plate Spacer	1
17	1/2-13 NLN	1/2-13 Nylon Locking Nut (zinc)	1
<b><u>FULL ASSEMBLY</u></b>			
18	3530447	Ergo Elevated Scale Plate Assembly	1
19	3530404	Ergo Scale Swing Out Bracket 1.5" Assembly	1
19	3530405	Ergo Scale Swing Out Bracket 6.5" Assembly	1
20	3530469	Eagle-Grip Scale Swing Out Bracket Assembly	1