

# ***Easy Lift Equipment Co., Inc.***

**2 Mill Park Court, Newark, Delaware 19713 - Phone: 800-233-1800 / 302-737-7000**

## **EASYLIFT COUNTERBALANCED DRUM TRANSPORTER WITH EG1 OR EG2L OPERATION & MAINTENANCE INSTRUCTIONS**



# **EASY LIFT EQUIPMENT EASYLIFT COUNTERBALANCED DRUM TRANSPORTER WITH EG1 OR EG2L OPERATION & MAINTENANCE INSTRUCTIONS**

## **INTRODUCTION**

EasyLift counterbalanced drum transporters utilize an automatic clamping mechanism for handling steel, plastic, or fiber chimed drums. These units vary in capacity from 100 to 800 lbs. The specification plate affixed to each unit provides the following information: model number, serial number, unit weight, and lifting capacity.

This manual contains information to instruct you on the proper use and maintenance of your EasyLift counterbalanced drum transporter. This manual should be made available to all operators that will use this equipment. Properly following the maintenance procedures will help ensure a safe and reliable service life. Do not operate this equipment until you have read and understand these instructions.

## **COMMISSIONING YOUR COUNTERBALANCED DRUM TRANSPORTER**

1. Perform a visual inspection for potential damage, including checking for hydraulic oil leaks.
2. Remove all packing materials, protective strapping, and wood shipping blocks. It is recommended to use protective eye gear when cutting any metal strapping. Then, using a company forklift, carefully lift and remove the drum transporter from the shipping pallet or crate.
3. Check that the ergonomic step-down floor lock is functioning properly by depressing one of the two small portions of the step-down pedal labeled “OFF” to release the floor lock. To engage the floor lock, depress the large portion of the step-down pedal labeled “ON”, which will engage contact with the floor and secure the equipment in place. With the floor lock disengaged, check that the caster wheels are free of obstruction and functioning properly.
4. Verify that lift and lower functions are in proper working order by pumping the larger foot pedal all the way down and allowing it to travel all the way back up in between each pump. Test the lowering function by pressing softly on the small lowering pedal. The lowering pedal is pressure sensitive, allowing the operator to control the speed of descent. Pressing down too hard on the lowering pedal while holding a load can cause the clamping mechanism to lower rapidly – use caution.

## DAILY SAFETY INSPECTION

1. Perform a visual inspection, checking for any apparent damage to the machine or any hydraulic oil leakage from previous use. Check all hydraulic fittings, components and connections and look under the machine for leaks.
2. Ensure that the step-down floor lock is functioning properly and that the wheels are free of obstructions.
3. Perform a visual inspection, checking for loose or damaged springs and jaws in the clamping mechanism

**Do not operate your EasyLift Drum Transporter if you notice any unsafe conditions that may have been caused by an accident or malfunction from previous use. Immediately report any unsafe conditions or issues with the equipment to your supervisor. Tag the machine properly to keep others from using it until the issue has been corrected.**

## SAFETY PRACTICES

1. Do not lift loads that exceed the machines' rated capacity.
2. Only lift the drum to the minimum height needed for proper floor clearance while transporting the drum to its destination. Do not transport or move a drum at heights greater than 6" (15cm) above floor level.
3. **Always** keep hands, feet and other objects clear of any pinch points, including mast channel(s), lifting and rotation chains (where applicable), the clamping mechanism(s), lift cylinder and *any* other moving parts. Also keep your hands and feet clear of the lifting area in front of the unit.
4. Do not use the machine on inclined floors having a slope of more than 5 degrees.
5. Never lay the equipment down horizontally.

## WARNINGS

- WARNING:** Do not lift or suspend loads over people. Stay clear of suspended loads.
- WARNING:** Do not attempt to operate the equipment beyond its rated capacity.
- WARNING:** Never move the machine when the load is at its maximum lifting height. Lower the mast so the drum has only the necessary floor clearance.
- WARNING:** Keep hands and feet away from pinch points, such as mast channel, lifting & rotation chains, clamping mechanism, lift cylinder and any other moving parts.
- WARNING:** Do not make alterations or modifications to the machine without authorization from Easy Lift Equipment.
- WARNING:** Do not leave the machine outside in inclement weather for extended periods.
- WARNING:** Never press the small lowering pedal too hard when lowering a load. The pedal is pressure sensitive allowing the drum to be lowered at a safe, controller speed. Pressing the lowering pedal too hard will cause the drum to lower rapidly causing property damage or personal injury.
- WARNING:** Never leave the machine unattended without applying the step-down floor lock. Leaving the machine unsecured may allow it to move inadvertently and cause property damage or personal injury.
- WARNING:** Never operate the machine on an inclined floor with a slope of more than 5 degrees.

## EASYLIFT COUNTERBALANCED DRUM TRANSPORTER OPERATING INSTRUCTIONS

### TO ENGAGE, PICK AND TRANSPORT A DRUM:

1. To begin, press down on the small lowering pedal of the lift cylinder so the lower clamping jaw rests below the chime of the drum that you want to pick up. If the lower clamping jaw does not lower below the drum's chime, refer to the instructions below for adjusting the height of the clamping mechanism on the mast. Once the clamping mechanism is appropriately set and lowered, approach the drum head-on and push the equipment forward until the clamping mechanism makes full, solid contact against the drum (which will cause the clamping mechanism to collapse downward). Keep the clamping mechanism pressed tightly against the drum and pump the larger foot pedal down and up until the lower clamping jaw engages with the chime of the drum. It is recommended to apply slight forward pressure while raising the clamp to help ensure a secure grip.
2. Continue to pump the larger foot pedal allowing the pedal to travel all the way up and pressing completely down to achieve the full stroke. The weight of the drum on the lower clamping jaw will activate the mechanism causing the upper jaw to clamp down on the chime, securing the drum. After the clamp is securely engaged continue pumping the foot pedal until the drum is elevated slightly above the pallet or floor level for safe travel.
3. Only lift the drum to the minimum height needed for proper floor clearance while transporting the drum to its destination. Do not transport or move a drum at heights greater than 6" (15cm) above floor level.

### TO RELEASE DRUMS:

1. Once you have arrived at the required destination, press softly on the smaller lowering pedal. The lowering pedal is pressure sensitive allowing the operator to control the speed of descent. Pressing down too hard on the lowering pedal can cause the drum to lower rapidly, potentially causing property damage or personal injury. Continue to apply pressure to the lowering pedal until the drum contacts the floor (or pallet) causing the upper clamping jaw to retract completely and allowing the drum to disengage from the clamp.

### ADJUSTING THE CLAMPING MECHANISM FOR VARIOUS HEIGHT DRUMS:

#### MODELS WITH THE INNER AND OUTER MAST:

1. First, press the smaller lowering pedal to ensure the mast(s) are fully lowered. Then, remove the circle cotter pin & stainless-steel adjusting pin **while holding the clamping mechanism with your other hand (failure to hold the clamping mechanism while removing the adjustment pin could cause the clamp to fall and cause injury)**. Raise or lower the clamping mechanism to the desired available position so that the lower clamping jaw rests slightly below the chime of the drum with the drum at floor level. Re-insert the adjustment pin & circle cotter pin to secure the clamping mechanism into place. The lowest position available with the standard outer mast design will enable the lower clamping jaw of the clamping mechanism to rest at 19" (48.3cm) in overall height. This will allow you to pick drums where the bottom of the chime rests above 19".

## **MODELS EQUIPPED WITH SCALE SYSTEMS**

If your equipment has a scale system, the indicator has already been factory calibrated and tested. The indicator has been disconnected and packaged separately for safe travel. Unpack the indicator from the box and attach it to the mounting bracket. Once securely mounted, connect the corresponding male and female indicator cables. Non-Intrinsically safe scale indicators have internal batteries. Intrinsically safe indicators have external batteries which need to be mounted and have a separate battery cable that needs to be securely connected to the back of the indicator. All scale indicators are provided with a separate set of instructions that are packaged along with the indicator. Please read the scale indicator operations manual for more specific instructions of use.

Turn the indicator “ON” and ensure it reads zero before engaging a drum. Follow the instructions listed above for engaging a drum. If handling drums containing liquids operators should allow the contents of the drum to settle prior to documenting drum weights. This will help ensure the most accurate possible measurements. Most scale indicators are set to display the weight in increments of 0.1 lb. or 0.05 kg. To speed up the process it is recommended to set the indicator to a lower sensitivity. This can be achieved by programming the indicator to read in .5 pounds or .25 kilograms or 1.0 or .5 kg. increments, this will take less time for the indicator to settle on a specific weight.

## **MAINTENANCE INSTRUCTIONS**

1. Before every usage, check that all springs, pins, casters, lift chains and chain anchors are in good working order and that the hydraulic cylinder works properly and isn't leaking.
2. On a monthly basis, spray light grade oil on moving parts in the clamping mechanism to ensure smooth operation. It is recommended to keep the clamping mechanism lubricated and free from foreign materials which may impede proper operation of jaws and springs. The Darcor™ casters provided on this equipment have precision sealed ball bearings and require no lubrication.
3. For heavy usage, it is recommended to replace all springs, hydraulic oil and sealing components of the hydraulic cylinder once each year.

# EASYLIFT COUNTERBALANCED DRUM TRANSPORTER MAINTENANCE CHECKLIST

			Maintenance Intervals			
			1 Mo	6 Mo	12 Mo	3 Years
<b>Structural Steel:</b>	1.1	Check for cracked welds on frame;		X		
	1.2	Check to verify that specification data plates are affixed to the unit;			X	
	1.3	Grease* mast, rollers and check roller condition.			X	
<b>Clamping Head(s):</b>	2.1	Inspect heads for loose or missing pins, cotter pins, springs, and replace as necessary;	X			
	2.2	Lubricate** clamping mechanisms;	X			
	2.3	Replace all springs;			X	
	2.4	Replace all pins, and links.				X
<b>Wheels:</b>	3.1	Grease* wheel swivel grease fittings;			X	
	3.2	Check wheels for excessive wear and proper alignment.			X	
<b>Hydraulic Cylinder:</b>	4.1	Check cylinder for leaks and proper operation.	X			
<b>Chain:</b>	5.1	Verify proper chain tension and inspect chain for damage.			X	
	5.2	Lubricate*** chain.			X	

The maintenance intervals refer to normal service conditions.

In high volume usage conditions, the intervals must be increased as required.

\* For Non-FDA equipment: NAPA Premium Performance Multi-Purpose Wheel Bearing Grease.

\* For FDA (gray color) equipment: Super Lube Synthetic Food Grade Grease with Syncolon PTFE.

\*\* For both Non-FDA & FDA Equipment: WD-40, Berkebile White Lithium Grease or comparable.

\*\*\* For both Non-FDA & FDA ANSI 60 Chain: *See below chart for Manufacturer recommendations*

HKK Chain Number ANSI	Temperature (F)							
	14°F to 32°F	32°F to 104°F	104°F to 122°F	122°F to 140°F	14°F to 32°F	32°F to 104°F	104°F to 122°F	122°F to 140°F
	Lubrication Type A & B				Lubrication Type C			
50	SAE 10	SAE 20	SAE 30	SAE 50	SAE 10	SAE 20	SAE 30	SAE 40
60	20	30	40	50	10	20	30	40

Hydraulic Fluid:

Non-FDA equipment: Hydraulic Oil AWG32

For FDA equipment: Food Grade 32/46 Hydraulic Synthetic Lubricant

# Easy Lift Equipment Co., Inc.

2 Mill Park Court, Newark, Delaware 19713 - Phone: 800-233-1800 / 302-737-7000

## Operator's Daily Checklist

### Drum Transporter (Foot Pump) with Eagle-Grip® Clamp, V-Pan or Roll Post

Inspections Performed by: \_\_\_\_\_

Note: This inspection must be made by the equipment operator **daily** at the start of the shift. Check (✓) the appropriate "OK" or "Needs Repair" field.

This Daily Checklist is intended to help verify that the equipment is in proper working order each day.

**More thorough Weekly, Monthly and Yearly Maintenance schedules should still be followed.**

VISUAL CHECK		DATE: / / / / / / / / / / / / / / / /													
		OK	Needs Repair	OK	Needs Repair	OK	Needs Repair	OK	Needs Repair	OK	Needs Repair	OK	Needs Repair	OK	Needs Repair
VISUAL CHECK: FRAME & MAST	<b>DATA PLATES &amp; WARNING DECALS</b> - Data Plates & Warning Decals are affixed to the unit and in good condition														
	<b>DAMAGE</b> - Look for bent, dented or broken parts. This includes hydraulic lines, electrical wires, frame welds, wheels, & bolted connections														
	<b>LIFT CHAIN</b> - Visually ensure lift chain is connected and not loose														
	<b>LIFT CYLINDER &amp; FOOT PEDALS</b> - Ensure that the hydraulic lift cylinder & both foot pedals appear in operable condition														
	<b>LEAKS</b> - Check for any leaking oil, hydraulic fluid or battery acid (if applicable)														
	<b>GUARDS</b> - Verify that all chain guards are in place and in proper condition														
VISUAL CHECK: EAGLE-GRIP CLAMP	<b>CLAMP DAMAGE</b> - Look for bent, dented or broken clamp components. This includes the clamp housing, the upper and lower clamping jaws, retaining pins, cotter pins, and springs														
	<b>CLAMP PINS</b> - Confirm that all retaining pins and cotter pins are accounted for and secure														
VISUAL CHECK: V-PAN OR ROLL POST	<b>V-PAN/ROLL POST DAMAGE</b> - Look for bent, dented or broken components. This includes all welds and bolted connections of both the V-Pan assembly and the Roll Post and mounting receiver, including all applicable safety pins, retaining pins, latching pins and cotter pins														
	<b>V-PAN/ROLL POST PINS</b> - Confirm that all applicable safety pins, retaining pins and cotter pins are accounted for and secure														
VISUAL: SCALE	<b>SCALE SYSTEM &amp; PRINTER</b> - If applicable, confirm that the scale and printer as well as all wires, and cables are in good condition and properly connected														

**Checklist Continued on Next Page**

# Easy Lift Equipment Co., Inc.

2 Mill Park Court, Newark, Delaware 19713 - Phone: 800-233-1800 / 302-737-7000

## Operator's Daily Checklist (cont.)

### Drum Transporter (Foot Pump) with Eagle-Grip® Clamp, V-Pan or Roll Post

OPERATIONAL CHECK		DATE: / /		/ /		/ /		/ /		/ /		/ /	
		OK	Needs Repair	OK	Needs Repair	OK	Needs Repair	OK	Needs Repair	OK	Needs Repair	OK	Needs Repair
OPERATIONAL CHECK: FRAME & MAST	<b>FOOT FLOOR LOCK</b> - Verify that the Foot Floor Lock engages and disengages properly												
	<b>WHEELS AND TRAVEL</b> - Confirm that the unit travels properly. Ensure that the wheels are aligned properly, unobstructed, and not damaged												
	<b>LIFT PEDAL</b> - Engage the Lift Pedal and ensure the inner mast raises properly												
	<b>LOWERING PEDAL</b> - Ensure the Lowering Pedal lowers the inner mast when the pedal is depressed												
	<b>MAST</b> - Ensure the clamping head, V-Pan or Roll Post moves smoothly up and down the mast, with no obstruction or unusual noises												
EAGLE-GRIP	<b>EAGLE-GRIP CLAMPING HEAD</b> - Verify that the Eagle-Grip Clamping Head engages and disengages a drum properly. Only lift the "test" drum to the minimum height required while completing this test												
V-PAN OR ROLL POST	<b>V-PAN/ROLL POST FUNCTION</b> - Verify proper function of all V-Pan or Roll Post components, including smooth rotation of the Stainless Steel V-Pan tray (if applicable), as well as proper operation of Roll Post rollers and/or folding capabilities (if applicable)												
SCALE & PRINTER	<b>SCALE SYSTEM &amp; PRINTERS</b> - If applicable, power up the scale and printer. Ensure the scale and printer are in proper working order												

List the details of all required repairs in the comments section below. Then, **tag and decommission the equipment for safety.**

**Comments (items needing repair or adjustment):** \_\_\_\_\_

\_\_\_\_\_

\_\_\_\_\_

\_\_\_\_\_

\_\_\_\_\_

**Caution** – If the equipment is found to be in need of repair or in any way unsafe, or contributes to an unsafe condition, the matter shall be reported immediately to the designated supervisor, and the equipment shall not be operated until it has been restored to a safe operating condition. If during operation, the equipment becomes unsafe in any way, the matter shall be reported immediately to the designated supervisor, and the equipment shall not be operated until it has been restored to safe operating condition. Do not make repairs or adjustments unless specifically authorized to do so.

# Easy Lift Equipment Co., Inc.

2 Mill Park Court, Newark, Delaware 19713 - Phone: 800-233-1800 / 302-737-7000

## EASY LIFT EQUIPMENT WARRANTY POLICY FOR MODELS WITH PREFIXES: ED/ER/EL/ELDR/EG & RCR

**Easy Lift Equipment (“ELE”)** warrants each new product to be free from factory material and workmanship defects, under normal use with proper maintenance, for a period of 12 months. Warranty coverage for this warranty period is provided by authorized dealers and includes parts. Labor is covered for the same periods of 12 months as outlined above. Please call ELE for the authorized repair dealer in your area.

ELE shall be the sole judge of the validity of any claim or defect and may elect to make any replacement or repair of any part thereof that it has agreed to be defective. Wearable Items such as: hoses, bearings, belts, brushes, seals, lift motors, clamp motors, relays, fuses, springs and wheels are wear items not covered under the warranty policy. ELE assumes no responsibility whatsoever to work done, parts replaced, or expenses incurred not specifically authorized by ELE. Normal maintenance or replacement of service items is not covered by this warranty. No warranty claims will be considered for customers with any delinquent outstanding balance. When batteries, battery chargers, scale printers or scale indicators are purchased from ELE with the equipment, the original manufacturer’s warranty applies.

### **WARRANTY LIMITATION/DISCLAIMERS:**

Easy Lift Equipment reserves the right to void warranty coverage if the unit has been overloaded beyond rated capacity; damaged due to: abuse, misuse, neglect, accidents, freight damage, improper usage, improper repair, and/or improper storage; or any modification or repair conducted in a manner not approved by Easy Lift Equipment. Equipment used in freezers, abrasive, corrosive, and/or excessively moist conditions must be properly equipped for the environment to ensure the warranty is not voided. Warranty questions and claims should be directed to our customer service department. ELE customer service representatives will help you assess and resolve the claim or assist you in contacting the local authorized dealer or representative. The warranty described here shall constitute the sole remedy of the authorized dealer and/or the initial purchaser. ELE neither assumes nor authorizes any person to assume for it any other obligation or responsibility in connection with this product warranty. In no event shall ELE be responsible for direct, indirect, special or consequential damages or any other delay or any economic or commercial loss resulting from Easy Lift Equipment’s performance or non-performance under this warranty. This warranty is expressly in lieu of all warranties, obligations or responsibilities of ELE dealers or other authorized source, expressed, implied or statutory.

### **SUBMITTING CLAIMS:**

To make a claim under this policy, please contact Easy Lift Equipment for assistance. We can be reached by calling 800-233-1800 ext. 4 for customer service or by writing to [sales@easylifteqpt.com](mailto:sales@easylifteqpt.com). Do not return defective parts unless a return authorization (RA) has been provided requesting the return. If requested, we will provide shipping information on how the part should be returned and bear the expense for the return shipping, if the part is proven to be defective. A copy of the work order made at the time of the repair and parts claimed under warranty may be requested for ELE’s inspection.

### **ORDERING PARTS:**

Easy Lift Equipment’s parts are distributed through our customer service department and ship the same day as ordered whenever possible. You will be well taken care of whenever parts, adjustments or repairs are needed. **When contacting ELE, please be sure to state the model and serial number for the equipment.** There is no cost for electronic copies of replacement manuals, parts lists and other general information containing part numbers and nomenclature. Most manuals contain parts pricing, but it is not guaranteed to be valid as parts pricing can change at any time without notice. Any customer service representative can provide timely parts quotations upon request. Adherence to above procedure will save time and provide prompt assistance when it counts. You are of course always welcome to bring to us any questions, comments or recommendations pertaining to your Easy Lift Equipment products.

### **MANUFACTURER CONTACT INFORMATION:**

Easy Lift Equipment Co., Inc.  
2 Mill Park Ct.  
Newark, DE 19713  
Email: [sales@easylifteqpt.com](mailto:sales@easylifteqpt.com)

Phone: 800-233-1800: 302-737-7000  
Fax: 302-737-7333  
Website: [www.easylifteqpt.com](http://www.easylifteqpt.com)

# EASY LIFT EQUIPMENT FIBER DRUM EG1 CLAMPING PROCEDURE

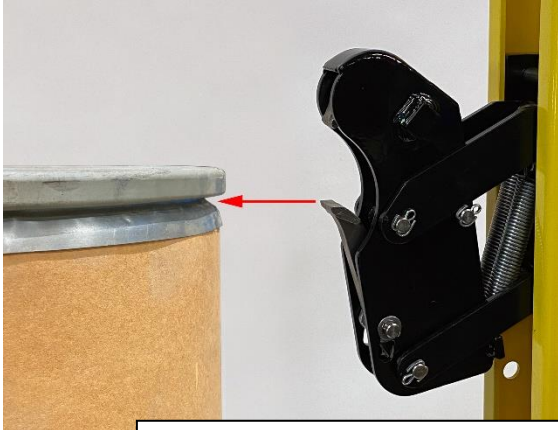

1. Raise the clamping mechanism until the lower jaw is just high enough to contact the metal skirt just below the locking band.

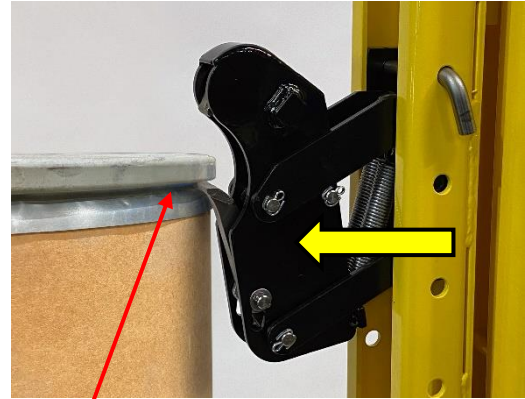

2. Then move the clamping mechanism forward so the lower jaw contacts the metal skirt under the drum's locking band and proceed to elevate the drum upward.



3. Maintain slight forward momentum while raising the drum so the lower clamping jaw maintains contact with the metal skirt. Do not allow the lower jaw to contact the paper portion of the fiber drum when elevating the drum.

## IMPORTANT:

It is important that the lower jaw does not contact the paper portion of the drum when raising the clamping mechanism. Keep the lower jaw away from the paper portion of the drum until the lower jaw of the clamping mechanism is high enough to contact the metal skirt below the locking band.

Then push the clamping mechanism forward to contact the skirt. Once contact has been made, proceed to elevate the clamping mechanism. If the lower jaw contacts the paper portion of the drum when elevating the drum, the clamping mechanism will attempt to clamp the drum in this position and miss or tear the skirt. If this is done incorrectly, lower the clamp and try again. The clamping mechanism can also grip the drum without the lid and locking band.

# EASY LIFT EQUIPMENT FIBER DRUM EG2L CLAMPING PROCEDURE

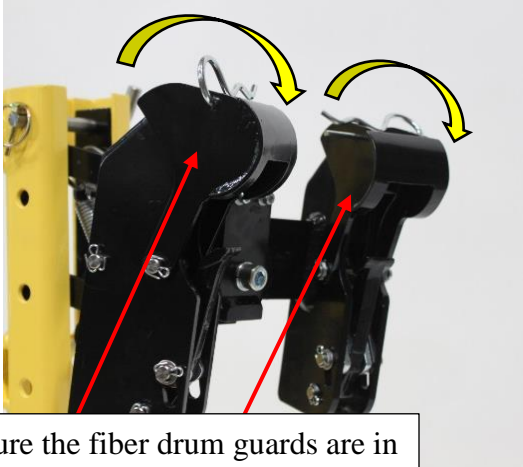

1. Ensure the fiber drum guards are in the forward position (closer to the clamp) and the cotter pins are locking the guards in place. The guards should always be in this position when handling fiber drums. The guards can be in the rearward position (closer to the mast) when handling steel or plastic drums.

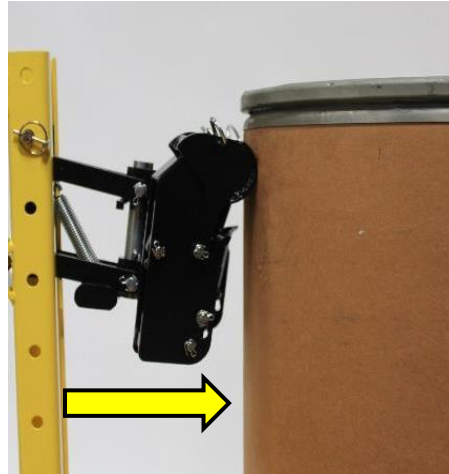

2. Push the unit forward so the fiber drum guards are contacting the paper portion of the drum.

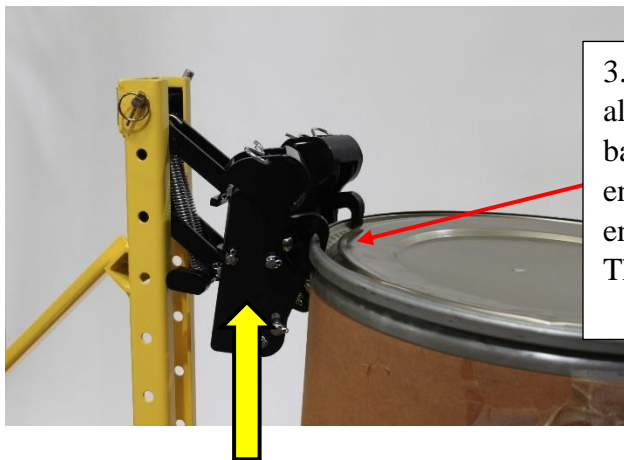

3. Elevate the clamping mechanism(s), allowing them to engage the locking band. After the clamp has fully engaged continue elevating the drum enough to ensure safe floor clearance. The drum can now be transported.

## IMPORTANT:

The fiber drum guards, when in the forward position, are designed to prevent the clamp from damaging the fragile paper portion of fiber drums. Great care should still be taken to ensure the clamping mechanism only contacts the metal skirt and locking band.

# EASY LIFT COUNTERBALANCED DRUM TRANSPORTER

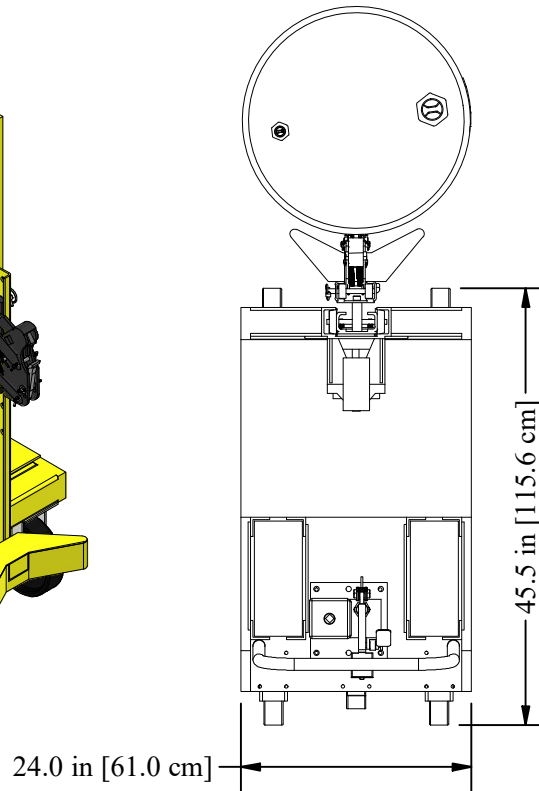
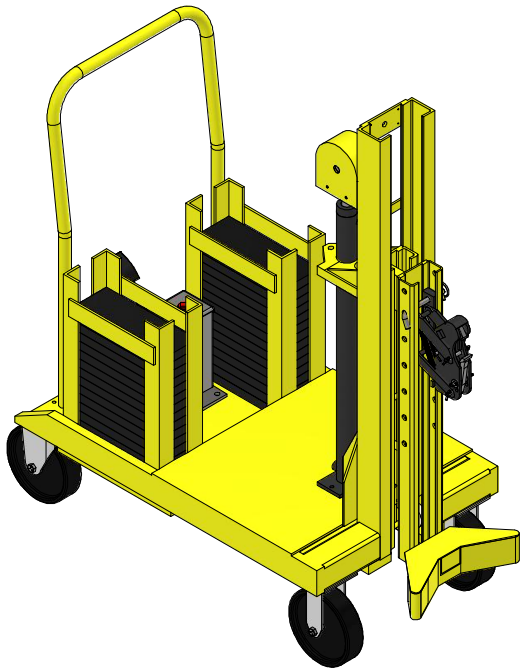

CAPACITY	COUNTERWEIGHT PER SIDE
400 lb [181 kg]	8
500 lb [227 kg]	10
600 lb [272 kg]	12
700 lb [318 kg]	14
800 lb [363 kg]	16

\* Counterweight per side may vary based on equipment configuration

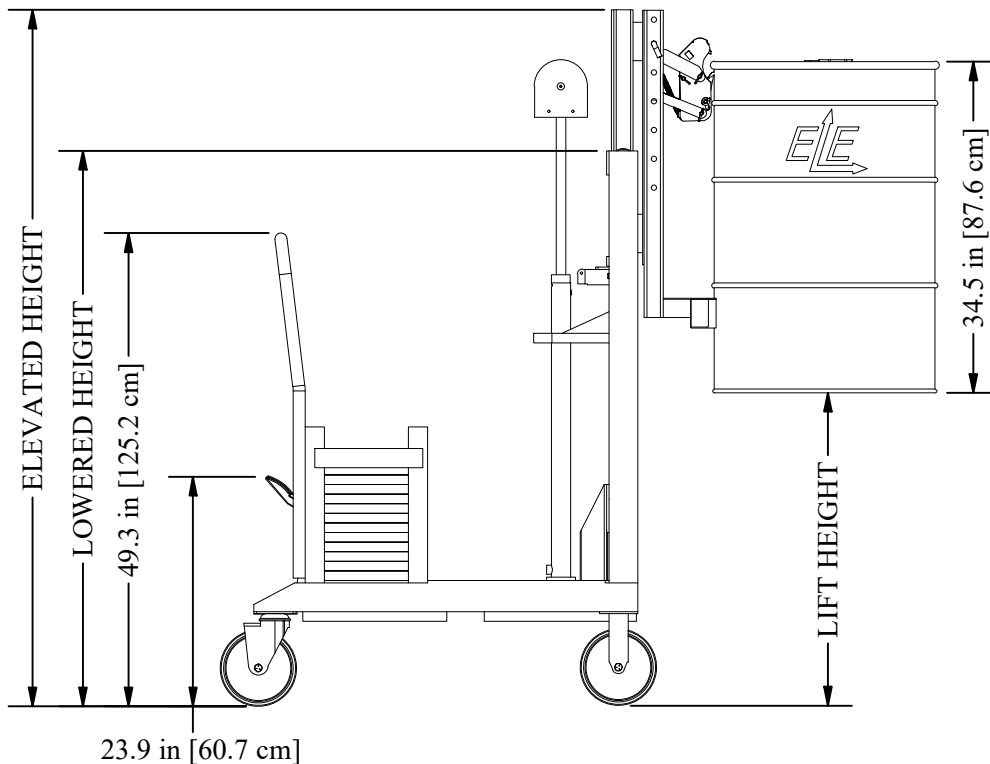

LIFT HEIGHT	LOWERED HEIGHT	ELEVATED HEIGHT
20 in [50.8 cm]	57.8 in [146.8 cm]	72.5 in [184.2 cm]
40 in [101.6 cm]	74.8 in [190.0 cm]	89.5 in [227.3 cm]
48 in [121.9 cm]	81.8 in [207.8 cm]	96.5 in [245.1 cm]
60 in [152.4 cm]	92.8 in [235.7 cm]	107.5 in [273.1 cm]
72 in [182.9 cm]	98.8 in [251.0 cm]	113.5 in [288.3 cm]
74 in [188.0 cm]	107.8 in [273.8 cm]	122.5 in [311.2 cm]

# EASYLIFT COUNTERBALANCE DRUM TRANSPORTER FRAME ASSEMBLY

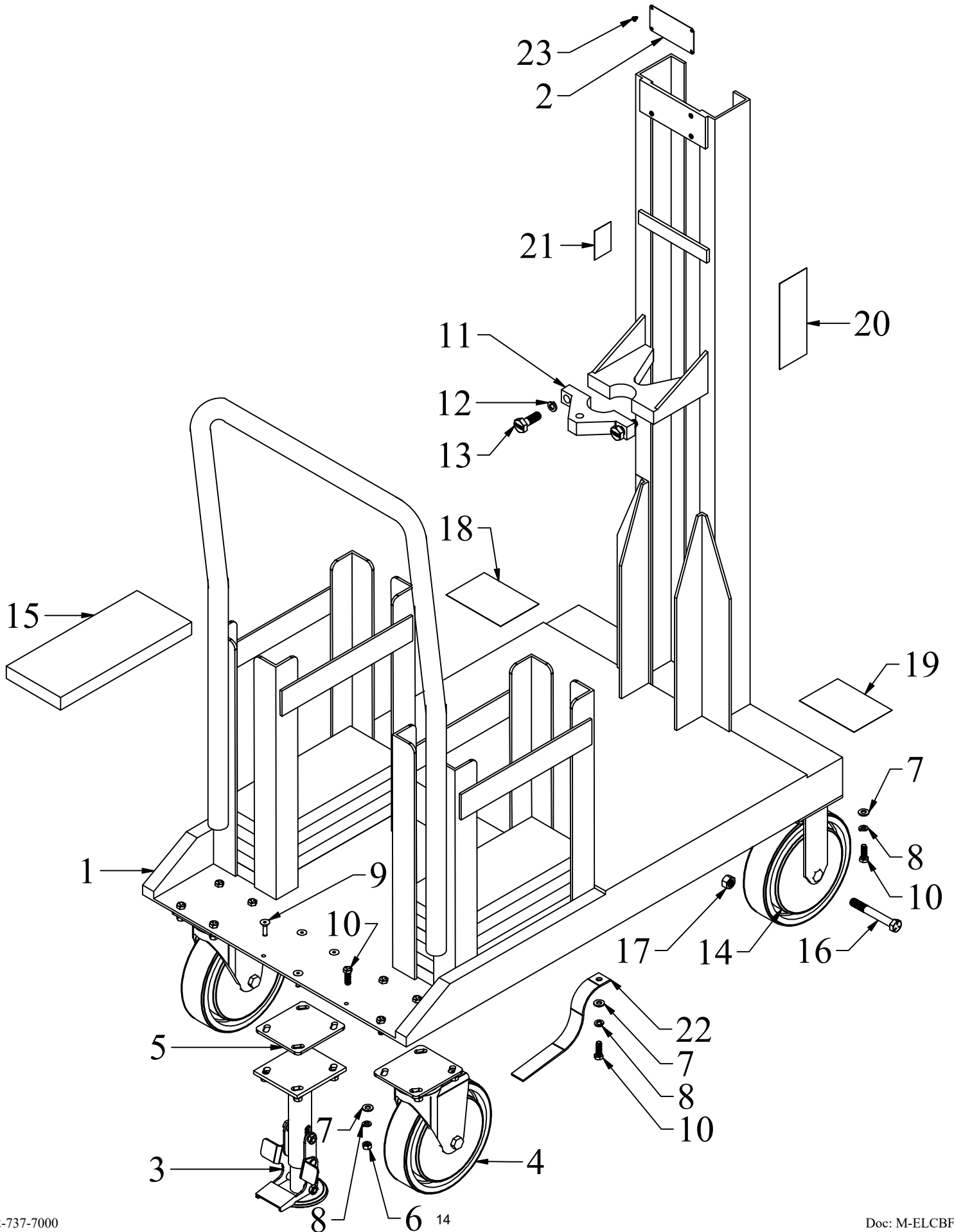

## EASYLIFT COUNTERBALANCE DRUM TRANSPORTER FRAME PARTS LIST

<u>ITEM</u>	<u>PART NO.</u>	<u>DESCRIPTION</u>	<u>QTY</u>
1	3530145	Frame - Contact Easy Lift Equipment for Specifications	1
2	MCL007031	Specification Plate	1
3	16LF0880	Step Down Floor Lock (for 8" wheels)	1
4	31-408-PSE	8" Swivel Caster with PSE Wheel	2
-	W-408-PSE	8" PSE Wheel Only	-
5	28Z17SP	1/4" Shim Plate (zinc plated)	1
6	5/16-18 HN	5/16-18 Finished Hex Nut (zinc)	12
6	5/16-18 HN-SS	5/16-18 Finished Hex Nut (stainless steel)	12
7	5/16 FW	5/16 Flat Washer (zinc)	21
7	5/16 FW-SS	5/16 Flat Washer (stainless steel)	21
8	5/16 LW	5/16 Lock Washer (zinc)	21
8	5/16 LW-SS	5/16 Lock Washer (stainless steel)	21
9	5/16-18 x 1 1/4 FSHCS-SS	5/16-18 x 1 1/4 Flat Socket Head Cap Screw (stainless steel)	4
10	5/16-18 x 1 HHCS	5/16-18 x 1 Hex Head Cap Screw Grade 5 (zinc)	17
10	5/16-18 X 1 HHCS-SS	5/16-18 x 1 Hex Head Cap Screw (stainless steel)	17
11	35091	Cylinder Clamp Bracket	1
11	35091-40	High Lift Cylinder Clamp Bracket	1
12	1/2 LW	1/2 Lock Washer (zinc)	2
12	1/2 LW-SS	1/2 Lock Washer (stainless steel)	2
13	1/2-13 x 1 1/2 HHCS	1/2-13 x 1 1/2 Hex Head Cap Screw Grade 5 (zinc)	2
13	1/2-13 x 1 1/2 HHCS-SS	1/2-13 x 1 1/2 Hex Head Cap Screw (stainless steel)	2
14	31-408R-PSE	8" Rigid Caster with PSE Wheel	2
-	W-408-PSE	8" PSE Wheel Only	-
15	1" x 5" x 12" HRFB CW	1" x 5" x 12" HRFB CB Counter Weight	-
15	1" x 4" x 12" HRFB CW	1" x 4" x 12" HRFB DC CB Counter Weight	-
16	1/2-13 x 3 3/4 HHCS	1/2-13 x 3 3/4 Hex Head Cap Screw Grade 5 (zinc)	4
16	1/2-13 x 3 3/4 HHCS-SS	1/2-13 x 3 3/4 Hex Head Cap Screw (stainless steel)	4
17	1/2-13 HN	1/2-13 Finished Hex Nut (zinc)	4
17	1/2-13 HN-SS	1/2-13 Finished Hex Nut (stainless steel)	4
18	ADART002	Attention Read Operations Manual Decal	1
19	ADART003	Weight Capacity (Use Weight, 600 lb Example "ADART600")	1
20	ADART016	ELE Address Decal (Vertical)	2
21	ADART009	Warning 5 Degree Decal for ELE & EL	1
22	S-207	Grounding Strap	1
23	6 x 1/4 RUDS-SS	6 x 1/4 Round Head U Drive Screw (stainless steel)	4

# INNER MAST ASSEMBLY

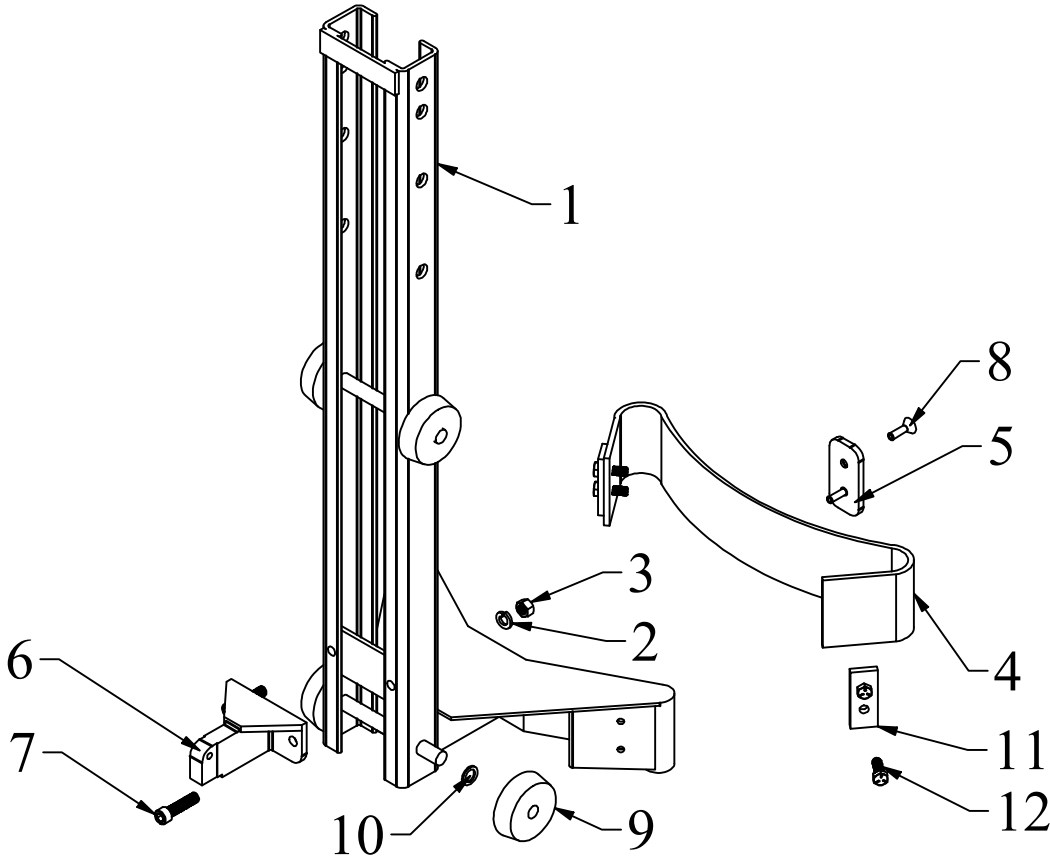

# INNER AND OUTER MAST ASSEMBLY

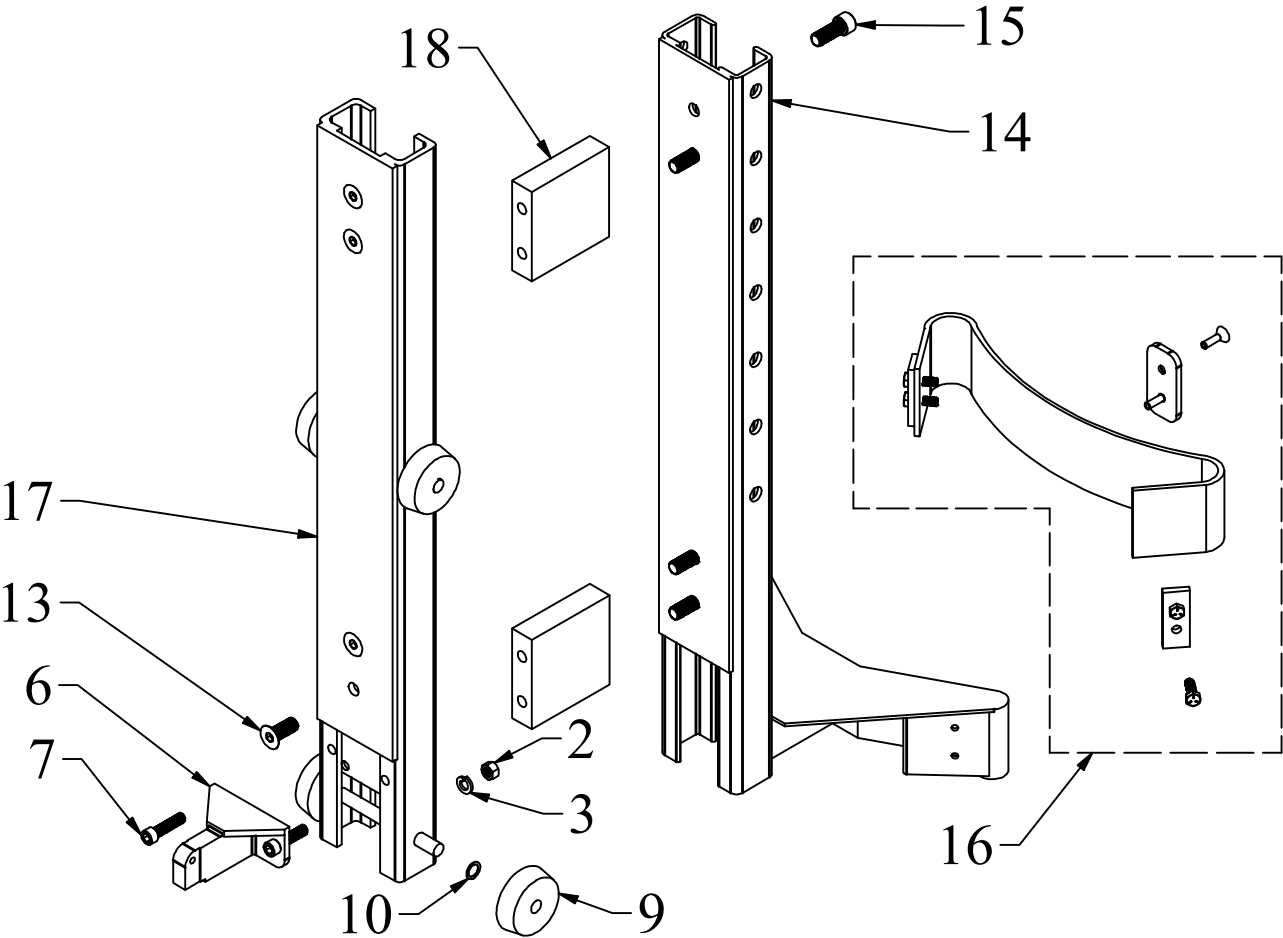

## INNER MAST PARTS LIST

<u>ITEM</u>	<u>PART NO.</u>	<u>DESCRIPTION</u>	<u>QTY</u>
1	3912	32" High Inner Mast with 5" Belt Cradle	1
2	3/8-16 HN	3/8-16 Finished Hex Nut (zinc)	2
2	3/8-16 HN-SS	3/8-16 Finished Hex Nut (stainless steel)	2
3	3/8 LW	3/8 Lock Washer (zinc)	2
3	3/8 LW-SS	3/8 Lock Washer (stainless steel)	2
4	5516	Rubber Belt Only (3" wide x 23" long, no hardware)	1
5	2580051	EG1/Ergo UHMW Belt Support	1
6	8912	Chain to Mast Bracket	1
6	8912HR	High Reach Chain to Mast Bracket	1
7	3/8-16 x 1 1/2 SHCS	3/8-16 x 1 1/2 Socket Head Cap Screw Alloy Plated	2
7	3/8-16 x 1 1/2 SHCS-SS	3/8-16 x 1 1/2 Socket Head Cap Screw (stainless steel)	2
8	5/16-18 x 1 FSHCS-SS	5/16-18 x 1 Flat Socket Head Cap Screw (stainless steel)	6
9	4008	Delrin Roller	4
10	90295A187	1/16" Nylon Flat Washer	-
10	95606A170	1/32" Nylon Flat Washer	-
11	2580050	EG1/Ergo Belts Clamp Straps	2
12	5/16-18 X 1 HHCS	5/16-18 x 1 Hex Head Cap Screw Grade 5 (zinc)	4
12	5/16-18 X 1 HHCS-SS	5/16-18 x 1 Hex Head Cap Screw (stainless steel)	4

## INNER AND OUTER MAST PARTS LIST

<u>ITEM</u>	<u>PART NO.</u>	<u>DESCRIPTION</u>	<u>QTY</u>
2	3/8-16 HN	3/8-16 Finished Hex Nut (zinc)	2
2	3/8-16 HN-SS	3/8-16 Finished Hex Nut (stainless steel)	2
3	3/8 LW	3/8 Lock Washer (zinc)	2
3	3/8 LW-SS	3/8 Lock Washer (stainless steel)	2
6	8912	Chain to Mast Bracket	1
6	8912HR	High Reach Chain to Mast Bracket	1
7	3/8-16 x 1 1/2 SHCS	3/8-16 x 1 1/2 Socket Head Cap Screw Alloy Plated	2
7	3/8-16 x 1 1/2 SHCS-SS	3/8-16 x 1 1/2 Socket Head Cap Screw (stainless steel)	2
9	4008	Delrin Roller	4
10	90295A187	1/16" Nylon Flat Washer	-
10	95606A170	1/32" Nylon Flat Washer	-
13	1/2-20 x 1 1/4 FSHCS	1/2-20 x 1 1/4 Flat Socket Head Cap Screw (zinc)	4
14	2580453	32" High Outer Mast with 3" Belt Cradle	1
14	2580459	32" High Outer Mast with 5" Belt Cradle	1
15	1/2-20 x 1 1/4 SHCS	1/2-20 x 1 1/4 Socket Head Cap Screw Alloy Plated	4
16	5516E	Optional: Belt Cradle Kit (3" wide x 23" long, includes all hardware)	1
17	2580401	32" High Inner Mast (Scale)	1
18	LCRB	Load Cell Replacement Block	2
18	HM1000	Load Cell with 4' cable	2

# COUNTERBALANCE DRUM TRANSPORTER LIFT CHAIN ASSEMBLY

COUNTERBALANCE FOOT PUMP MODELS  
GREATER THAN STANDARD 20" LIFT

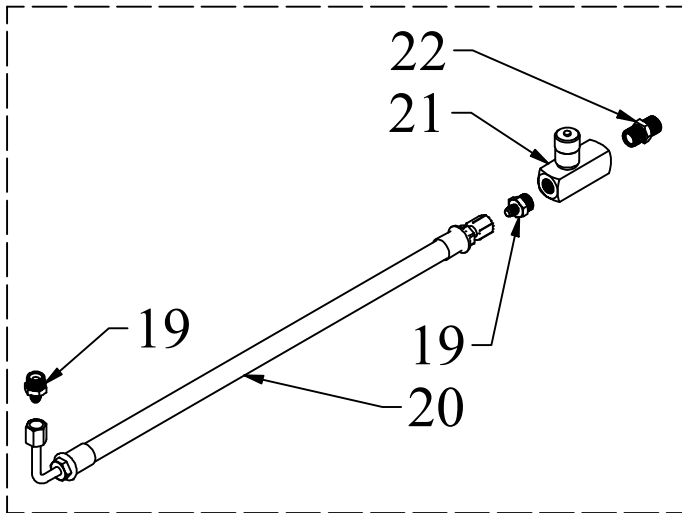

COUNTERBALANCE FOOT PUMP MODELS  
WITH STANDARD 20" LIFT

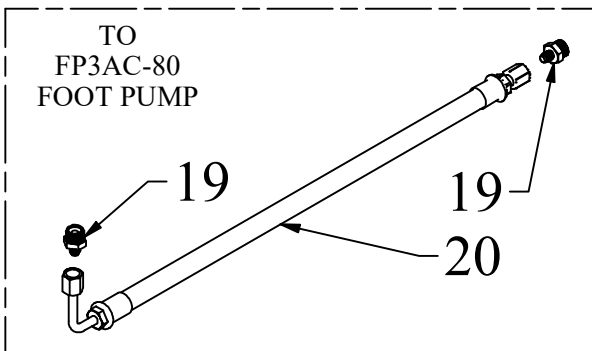

COUNTERBALANCE DC ONLY

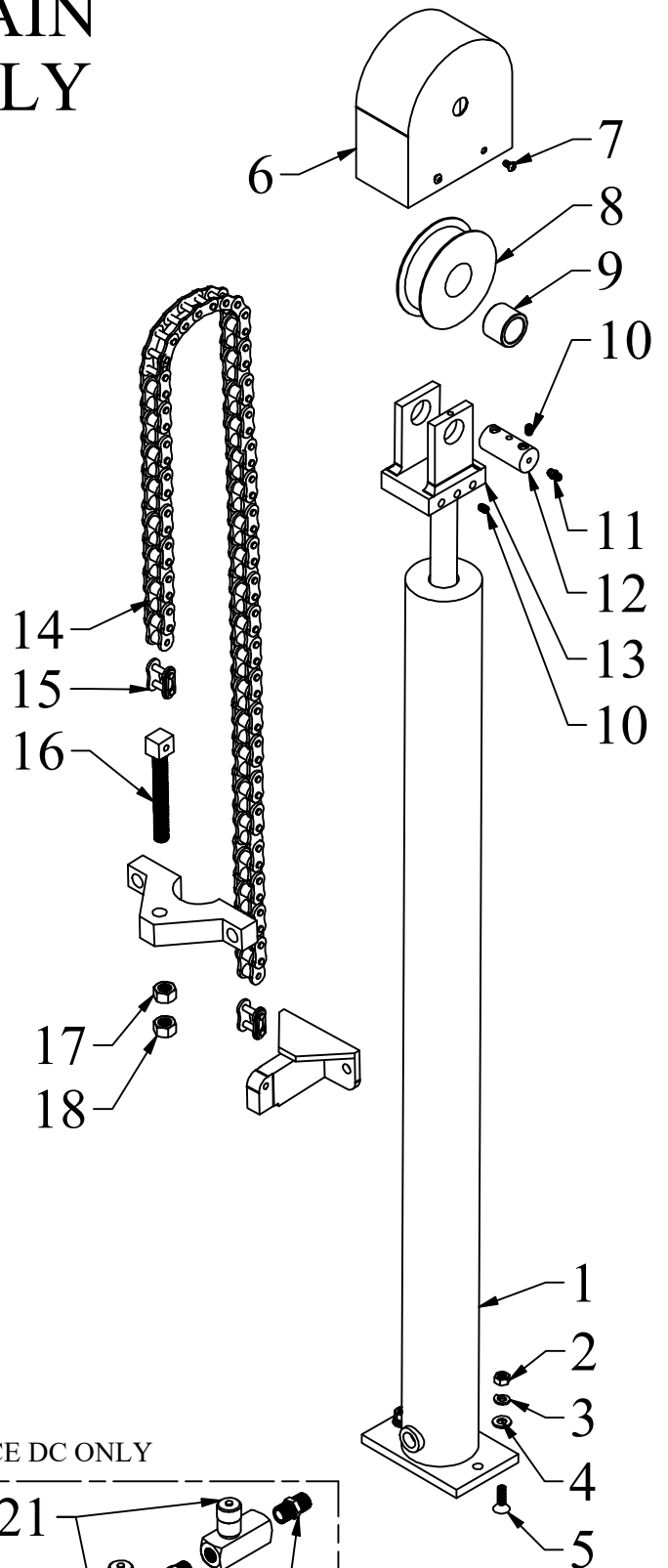
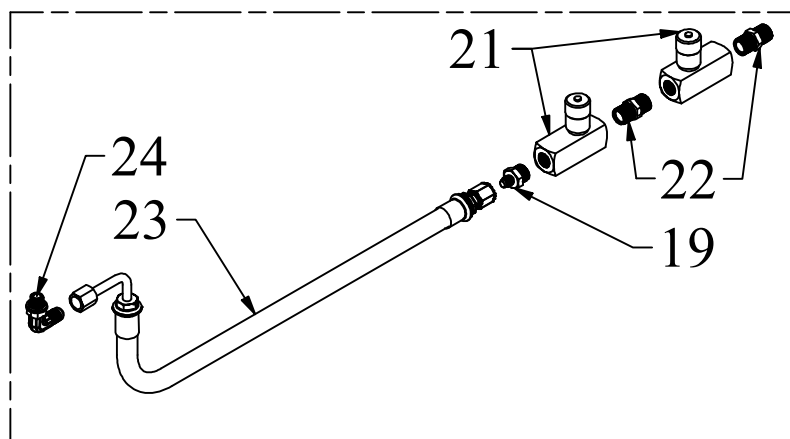

## COUNTERBALANCE DRUM TRANSPORTER LIFT CHAIN PARTS LIST

<u>ITEM</u>	<u>PART NO.</u>	<u>DESCRIPTION</u>	<u>QTY</u>
1	EL1.5-1.0-24BZ	Hydraulic Lift Cylinder	1
1	EL1.5-1.0-28BZ	Hydraulic Lift Cylinder	1
1	EL1.5-1.0-32BZ	Hydraulic Lift Cylinder	1
1	EL1.5-1.0-36BZ	Hydraulic Lift Cylinder	1
1	EL1.5-1.0-40BZ	Hydraulic Lift Cylinder	1
-	EL1.5PISTONKIT	Seal Kit (new piston, seals & wire)	-
2	5/16-18 HN	5/16-18 Finished Hex Nut (zinc)	2
2	5/16-18 HN-SS	5/16-18 Finished Hex Nut (stainless steel)	2
3	5/16 LW	5/16 Lock Washer (zinc)	2
3	5/16 LW-SS	5/16 Lock Washer (stainless steel)	2
4	5/16 FW	5/16 Flat Washer (zinc)	2
4	5/16 FW-SS	5/16 Flat Washer (stainless steel)	2
5	5/16-18 x 1 1/4 FSHCS-SS	5/16-18 x 1 1/4 Flat Socket Head Cap Screw (stainless steel)	2
6	3022	4" Sheave Wheel Cover	1
7	10-24 x 3/8 BSC-SS	10-24 x 3/8 Button Socket Cap 18/8 (stainless steel)	4
8	55061	4" Sheave Wheel	1
9	CB-1622-08	Sheave Wheel Bushing	1
10	93445A425	1/4"-20 x 3/8" Stainless Steel Knurl-Grip Set Screw	2
11	1095K41	1/4"-28 Grease Fitting	1
12	45061	Sheave Wheel Axle (1" x 2.125")	1
13	7912-4-1	Sheave Wheel Bracket 4" (1" bore)	1
14	RC060RC1-49	Chain-Ansi 60 (49" Long)	1
14	RC060RC1-49PC	FDA Chain-Ansi 60 (49" Long)	1
14	RC060RC1-65	Chain-Ansi 60 for Ergo (65" Long)	1
14	RC060RC1-65PC	FDA Chain-Ansi 60 for Ergo (65" Long)	1
14	RC060RC1-73	Chain-Ansi 60 for Ergo (73" Long)	1
14	RC060RC1-73PC	FDA Chain-Ansi 60 for Ergo (73" Long)	1
15	60HMCL	ANSI 60 Link	2
15	ARC060SCL1	FDA ANSI 60 Link	2
16	2022	Chain Adjuster for ANSI 60 Chain	1
17	1/2-13 HN	1/2-13 Finished Hex Nut (zinc)	1
17	1/2-13 HN-SS	1/2-13 Finished Hex Nut (stainless steel)	1
18	1/2-13 NLN	1/2-13 Nylon Locking Nut (zinc)	1
18	1/2-13 NLN-SS	1/2-13 Nylon Locking Nut (Stainless Steel)	1
19	6-6 FTX-S	# Male Connector	2 / 1
20	487TC-6-F-G-20	20" long 3/8" Hydraulic Hose w/ (1) Female Swivel Straight & (1) Female 90D ends	1
21	F600B	## Flow Control 3/8" NPT	1 / 2
22	3/8 FF-S	## Hex Nipple 3/8"	1 / 2
23	487TC-6-F-I-21	21" long 3/8" Hydraulic Hose w/ (1) Fml Swvl St. & (1) Fml 90° Long Drop Elbow	1
24	6C4OMXS	* HPI 90 Deg Fitting (Post 2013)	1
24	6-6 C4OMXS	** 90 Male Elbow 3/8 BSPP (for Rexroth Pump)	1

# First quantity CB Foot Pump / Second quantity CB DC

## First quantity CB Foot Pump greater than 20" of lift / Second quantity CB DC

\* Fitting for HPI Pump

\*\* Fitting for Rexroth Pump

# FP3AC-80 SINGLE PISTON CAM RELEASE FOOT PUMP ASSEMBLY

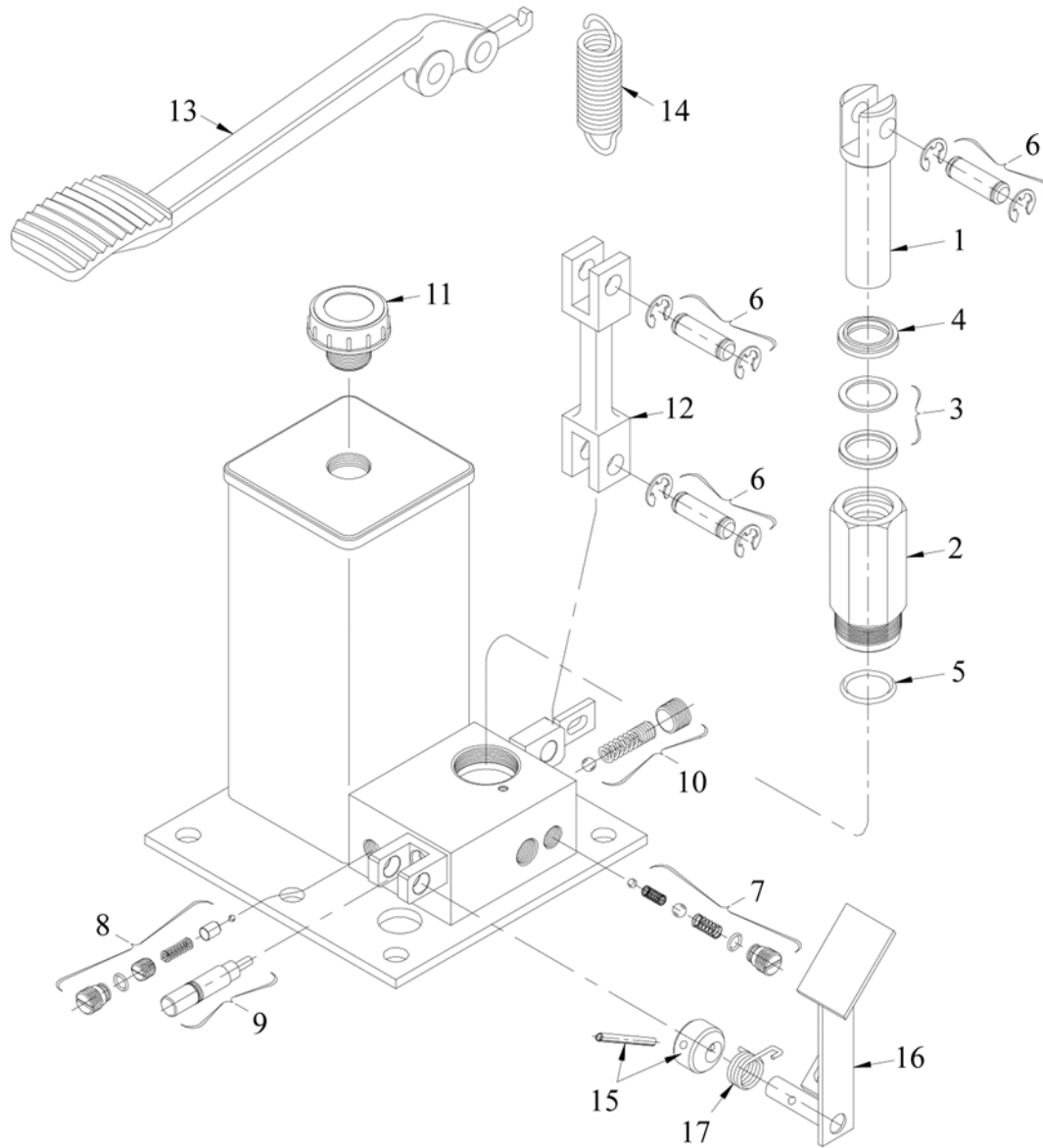

## FP3AC-80 SINGLE PISTON CAM RELEASE FOOT PUMP PARTS LIST

<u>ITEM</u>	<u>PART NO.</u>	<u>DESCRIPTION</u>	<u>QTY</u>
	FP3AC80	Foot Pump Assembly	1
1	P3-2	Pump Piston	1
2	P3-3	Piston Barrel	1
3	P3-4RP	Pump Piston Packing	1
4	P3-6	Packing Wiper	1
5	P1-20	Pump Barrel Seal	1
6	CP13-10RP	Piston Pin / Link Pin (Including Rings)	3
7	P1-12RP	Pump Valve (Complete)	1
8	P3-13RP	Overload Valve	1
9	CP13-17RP	Release Plunger	1
10	PAC18-RP	Release Valve	1
11	P1-16	Breather Screw	1
12	CP13-12	Pump Link	1
13	FCP12-9	Foot Lever	1
14	FCP13-23	Foot Lever Return Spring	1
15	FCP13-13RP	Release Lever Pin and Cam	1
16	FP1AC-14	Foot Release Lever	1
17	FP1AC-95	Release Spring	1
 <b><u>REPAIR KIT</u></b>			
	P3AC-RK	FP3AC-80 Foot Pump Repair Kit	1
 <b><u>REPAIR KIT INCLUDES</u></b>			
3	P3-4RP	Pump Piston Packing	1
4	P3-6	Packing Wiper	1
5	P1-20	Pump Barrel Seal	1
7	P1-12RP	Pump Valve (Complete)	1
8	P3-13RP	Overload Valve	1
9	CP13-17RP	Release Plunger	1
10	PAC18-RP	Release Valve	1

# EG1 LIGHT DUTY SINGLE CLAMPING MECHANISM ASSEMBLY

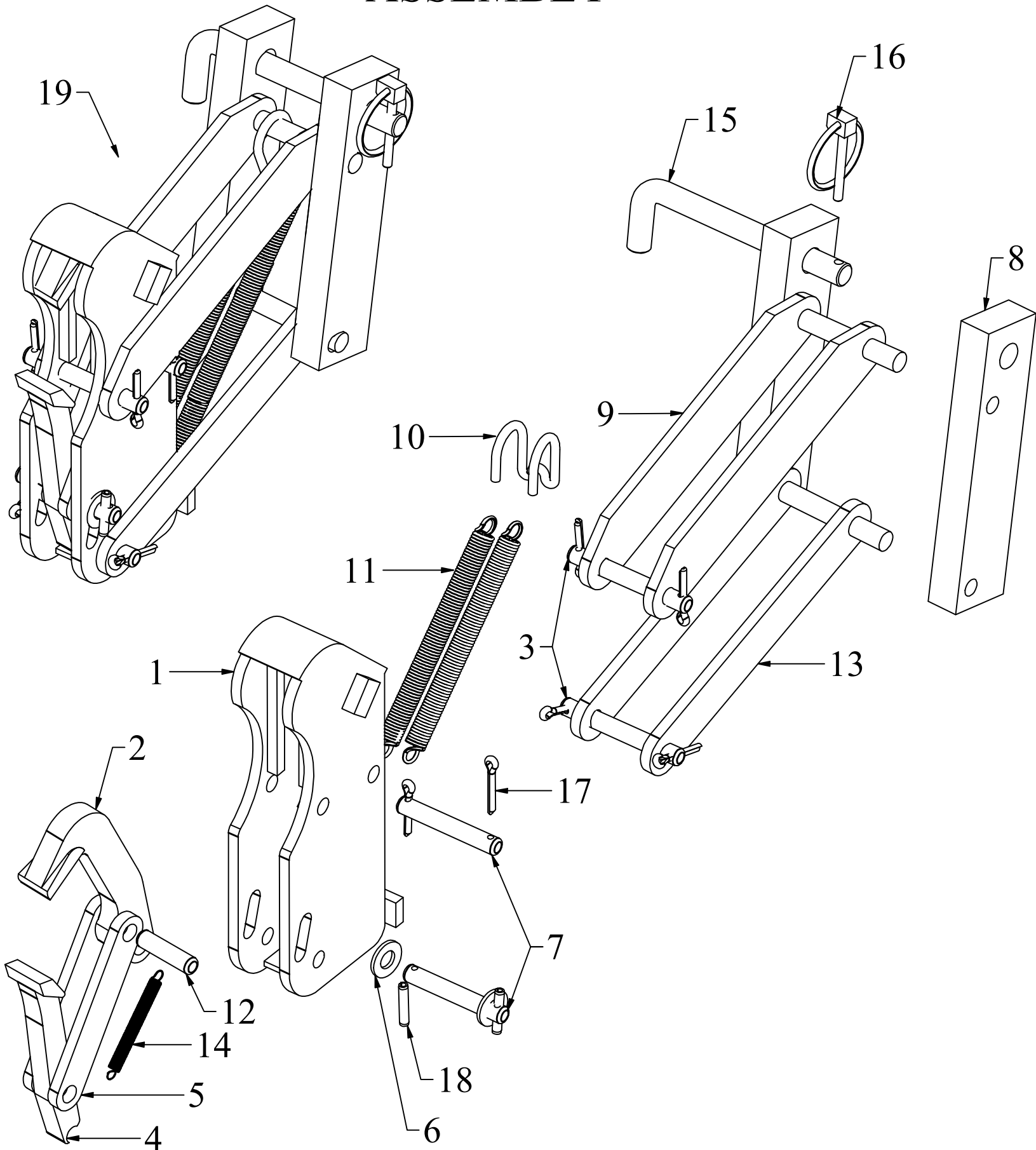

## EG1 LIGHT DUTY SINGLE CLAMPING MECHANISM PARTS LIST

<u>ITEM</u>	<u>PART NO.</u>	<u>DESCRIPTION</u>	<u>QTY</u>
1	6302	Housing (Black Powder Coating)	1
1	6302SS	Housing (Stainless Steel)	1
2	9107SS	Stainless Steel Upper Jaw (Spark Resistant)	1
3	15104-1SS	3/8" x 2.242" Pin, Fibre Guard, Housing to Clevis (stainless steel)	2
4	7107SS	Stainless Steel Lower Jaw (Spark Resistant)	1
5	13009-1	Link, Jaw to Jaw (zinc)	2
5	13009-1SS	Link, Jaw to Jaw (stainless steel)	2
6	C616 FW-SS	C616 Flat Washer (stainless steel)	2
7	16104-1SS	3/8" x 1.770" Pin, Upper Jaw Link (stainless steel)	2
8	8002	Adjustment Slide (FDA Black Powder Coating)	2
8	8002SS	Adjustment Slide (Stainless Steel)	2
9	5912	Upper Clevis 8" (FDA Black Powder Coating - 5" Belt Cradle)	1
9	5912SS	Upper Clevis 8" (Stainless Steel - 5" Belt Cradle)	1
9	5912S	Upper Clevis 6" (FDA Black Powder Coating - 3" Belt Cradle)	1
9	5912SS-S	Upper Clevis 6" (Stainless Steel - 3" Belt Cradle)	1
10	8996-2	Clevis Spring Hook (Stainless Steel)	1
11	8206	Clevis Spring (zinc)	2
12	41041SS	3/8" x 1" Pin, Upper Jaw to Link, short (stainless steel)	1
13	6912	Lower Clevis 7 1/2" (FDA Black Powder Coating - 5" Belt Cradle)	1
13	6912SS	Lower Clevis 7 1/2" (Stainless Steel - 5" Belt Cradle)	1
13	6912S	Lower Clevis 5 1/2" (FDA Black Powder Coating - 3" Belt Cradle)	1
13	6912SS-S	Lower Clevis 5 1/2" (Stainless Steel - 3" Belt Cradle)	1
14	1206	Spring, Jaw to Housing (stainless steel)	1
15	10204-1SS	1/2" x 4-1/2" Adjusting Pin (stainless steel)	1
16	HANG-1	3/16 x 1-1/4 Shank Lynch Pin "Hang 1" (9016)	1
16	HANG-1SS	3/16 x 1-1/4 Shank Lynch Pin "Hang 1" Stainless Steel	1
17	3006-CP	Cotter Pin, 1/8" x 3/4" (zinc)	6
17	1/8 x 3/4 CP-SS	1/8 x 3/4 Cotter Pins (stainless steel)	6
18	5/32 x 1/2 Roll Pin	Stainless Steel 5/32 x 1/2 Roll Pin	2
	B-800	White Lithium Grease Can	1
<b><u>FULL ASSEMBLIES</u></b>			
19	9004	EG1 Single Clamping Mechanism (FDA Black Powder Coating - 5" Belt Cradle)	
19	9004S	EG1 Single Clamping Mechanism (FDA Black Powder Coating - 3" Belt Cradle)	
19	9004SRC	EG1 Single Clamping Mechanism (Stainless Steel Housing - Spark Resistant - 5" Belt Cradle)	
19	9004SRC-S	EG1 Single Clamping Mechanism (Stainless Steel Housing - Spark Resistant - 3" Belt Cradle)	
19	9004SS	EG1 Single Clamping Mechanism (FULL Stainless Steel - Spark Resistant - 5" Belt Cradle)	
19	9004SS-S	EG1 Single Clamping Mechanism (FULL Stainless Steel - Spark Resistant - 3" Belt Cradle)	
<b><u>PREVENTATIVE MAINTENANCE KITS</u></b>			
	EG1PMKIT	EG1 Preventative Maintenance Kit	
	EG1BCPMKIT	EG1 Preventative Maintenance Kit w/ Belt Cradle	

**EG1 SINGLE CLAMPING MECHANISM  
PREVENTATIVE MAINTENANCE KIT BREAKDOWN**

**EG1PMKIT - EG1 PREVENTATIVE MAINTENANCE KIT**

<u>ITEM</u>	<u>PART NO.</u>	<u>DESCRIPTION</u>	<u>QTY</u>
11	8206	Clevis Spring (zinc)	2
14	1206	Spring, Jaw to Housing (stainless steel)	1
16	HANG-1	3/16 x 1-1/4 Shank Lynch Pin "Hang 1" (9016)	1
17	3006-CP	Cotter Pin, 1/8" x 3/4" (zinc)	6
18	5/32 x 1/2 Roll Pin	Stainless Steel 5/32 x 1/2 Roll Pin	2
	B-800	White Lithium Grease Can	1

**EG1BCPMKIT - EG1 PREVENTATIVE MAINTENANCE WITH BELT CRADLE KIT**

<u>PART NO.</u>	<u>DESCRIPTION</u>	<u>QTY</u>
11	8206	Clevis Spring (zinc)
13	5516E	Optional: Belt Cradle Kit (3" wide x 23" long, includes all hardware)
14	1206	Spring, Jaw to Housing (stainless steel)
16	HANG-1	3/16 x 1-1/4 Shank Lynch Pin "Hang 1" (9016)
17	3006-CP	Cotter Pin, 1/8" x 3/4" (zinc)
18	5/32 x 1/2 Roll Pin	Stainless Steel 5/32 x 1/2 Roll Pin
	B-800	White Lithium Grease Can

**EG1SRCPMKIT - EG1 PREVENTATIVE MAINTENANCE KIT**

<u>ITEM</u>	<u>PART NO.</u>	<u>DESCRIPTION</u>	<u>QTY</u>
11	8206	Clevis Spring (zinc)	2
13	5516E	Optional: Belt Cradle Kit (3" wide x 23" long, includes all hardware)	1
14	1206	Spring, Jaw to Housing (stainless steel)	1
16	HANG-1SS	3/16 x 1-1/4 Shank Lynch Pin "Hang 1" Stainless Steel	1
17	1/8 x 3/4 CP-SS	1/8 x 3/4 Cotter Pins (stainless steel)	6
18	5/32 x 1/2 Roll Pin	Stainless Steel 5/32 x 1/2 Roll Pin	2
	B-800	White Lithium Grease Can	1

**THIS PAGE INTENTIONALLY LEFT BLANK**

# EAGLE-GRIP 1 MAUSER CLAMPING MECHANISM ASSEMBLY

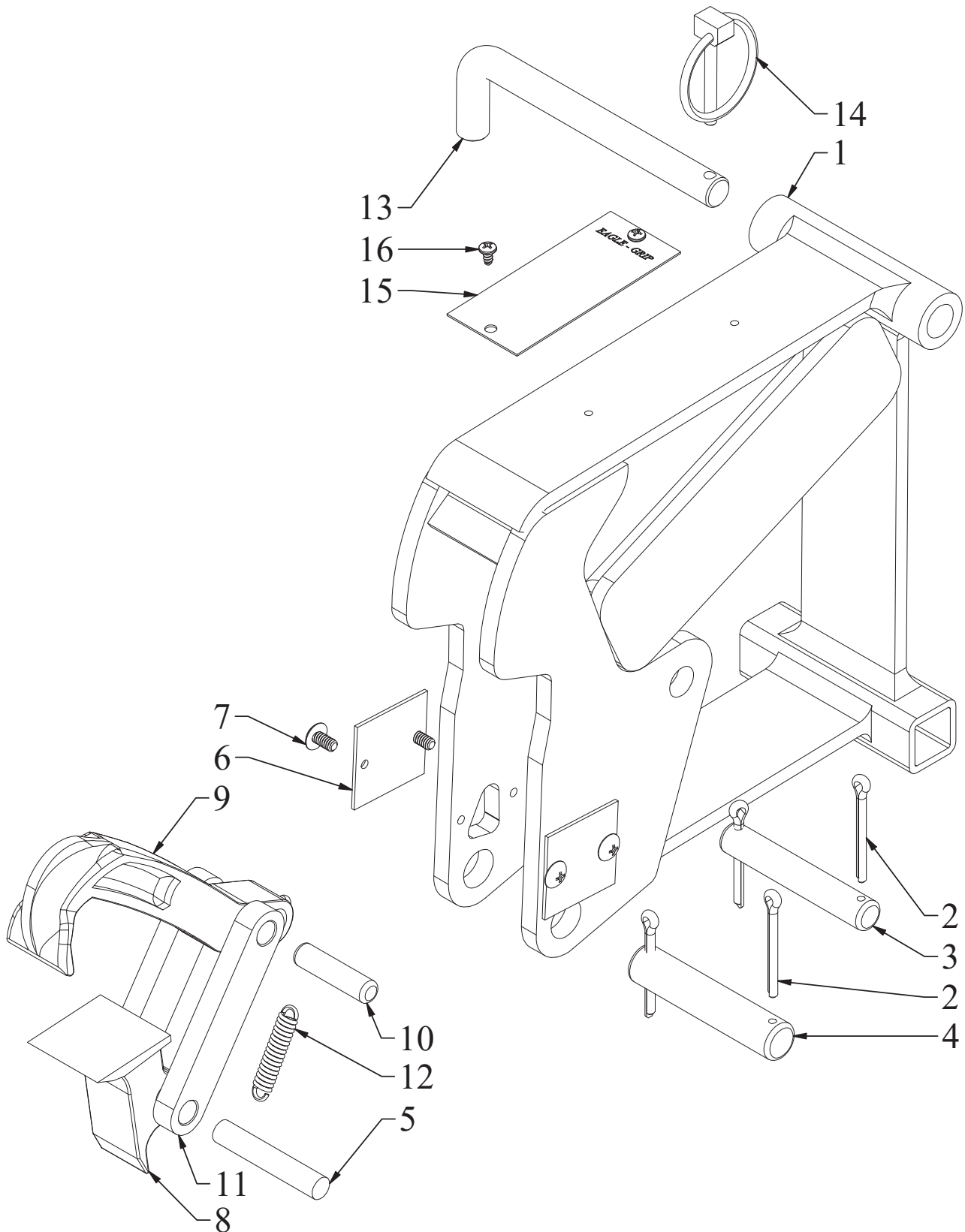

## EAGLE-GRIP 1 MAUSER CLAMPING MECHANISM PARTS LIST

<u>ITEM</u>	<u>PART NO.</u>	<u>DESCRIPTION</u>	<u>QTY</u>
1	7902M3	Mauser Housing for 3" Cradle (Black Powder Coating)	1
1	7902M5	Mauser Housing for 5" Cradle (Black Powder Coating)	1
2	6006-CP	Cotter Pin, 5/32" x 1" (zinc)	4
3	16033-1	1/2" x 2.625" Pin, Clevis (zinc)	1
4	3530067	5/8" x 2-7/8" 316 Stainless Steel Pin	1
5	62041	3/8" x 2.13" Pin, Link to Lower Jaw (zinc)	1
6	TSRBS .0625	1 1/2 x 1 1/2 Shim .0625 (1/16")	2
7	10-24 X 3/8 BSC-SS	10-24 x 3/8 Button Socket Cap 18/8 (stainless steel)	4
8	5107M	Mauser Lower Clamp Jaw (Black Powder Coating)	1
9	1007M	Mauser Upper Clamp Jaw (Black Powder Coating)	1
10	72041	3/8" x 1-1/2" Pin, Link to Upper Jaw (zinc)	1
11	70091	Link, Jaw to Jaw	2
12	4306	Jaw Spring (zinc)	1
13	10204-1SS	1/2" x 4-1/2" Adjusting Pin (stainless steel)	1
14	HANG-1	3/16 x 1-1/4 Shank Lynch Pin "Hang 1" (9016)	1
15	MCL044991	PM Tag	1
16	6 x 1/4 RUDS-SS	6 x 1/4 Round Head U Drive Screw (stainless steel)	2
 <b><u>FULL ASSEMBLIES</u></b>			
17	9004M3	EG1 Mauser Clamping Mechanism for 3" Cradle (Black Powder Coating)	
17	9004M5	EG1 Mauser Clamping Mechanism for 5" Cradle (Black Powder Coating)	

# EG2 LIGHT DUTY DOUBLE CLAMPING MECHANISM ASSEMBLY

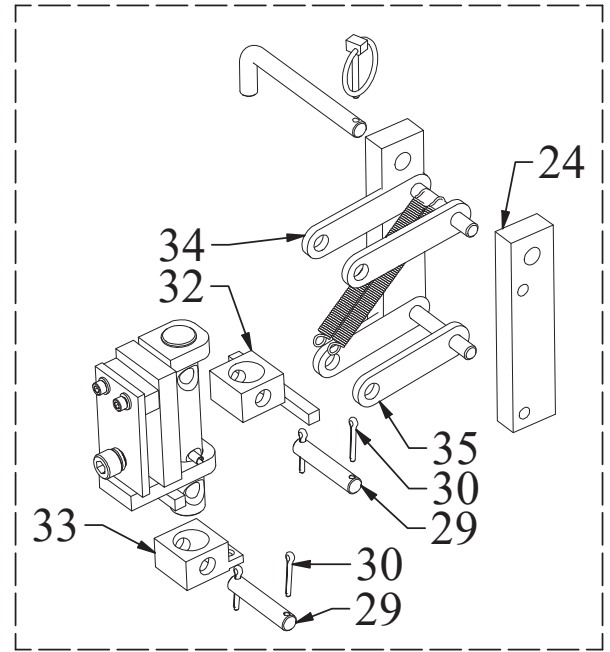
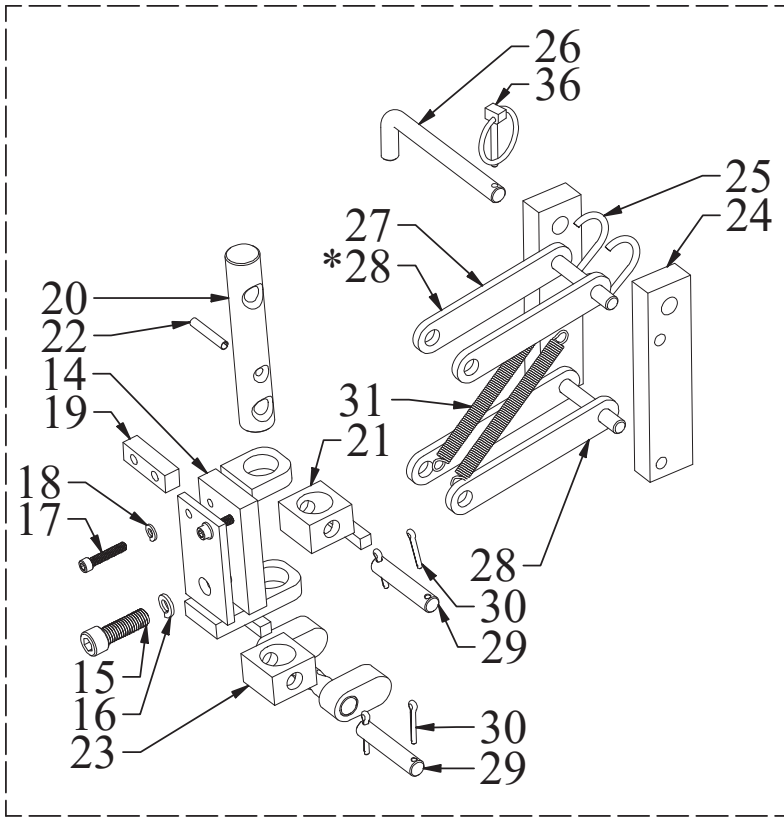

SEEN ON LEFT: **ERGO UNITS WITH A 5" BELT CRADLE** WILL PRIMARILY USE A 6" UPPER CLEVIS (#27) AND A 5-1/2" LOWER CLEVIS (#28). ALONG WITH A LOWER PIVOT BLOCK WITH OVAL STOP BARS (#23) AND AN UPPER PIVOT BLOCK WITH A 2-1/4" STOP BAR (#21).

**\*EAGLE-GRIP ATTACHMENTS** WILL PRIMARILY USE 5-1/2" LOWER CLEVISES (#28) FOR BOTH THE TOP AND BOTTOM CLEVISES.

SEEN ON THE RIGHT: **ERGO UNITS WITH A 3" BELT CRADLE** WILL PRIMARILY USE A 4-1/2" UPPER CLEVIS (#34) AND A 4" LOWER CLEVIS (#35). ALONG WITH A LOWER PIVOT BLOCK (#33) AND AN UPPER PIVOT BLOCK WITH A 3-3/4" STOP BAR (#32).

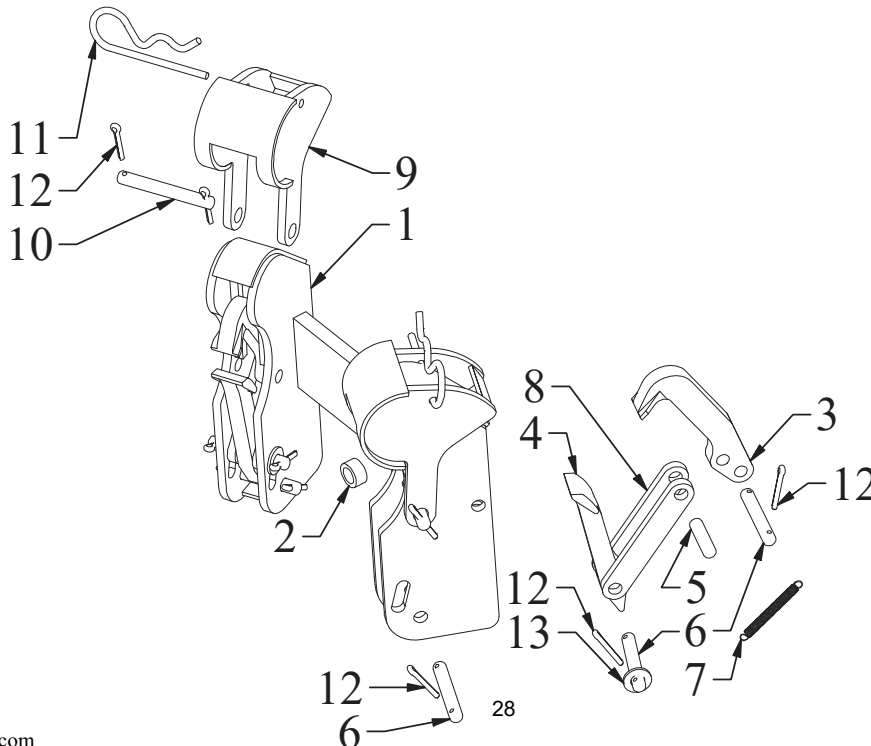

**EG2 LIGHT DUTY DOUBLE CLAMPING MECHANISM  
PARTS LIST**

<u>ITEM</u>	<u>PART NO.</u>	<u>DESCRIPTION</u>	<u>QTY</u>
1	7302R	Housing, Double Clamping Mechanism (Black Powder Coating)	1
1	7302RSS	Housing, Double Clamping Mechanism (Stainless Steel)	1
2	10001	Bushing, Housing Yolk Trunion (zinc)	1
3	9107SS	Stainless Steel Upper Jaw (Spark Resistant)	2
4	7107SS	Stainless Steel Lower Jaw (Spark Resistant)	2
5	41041SS	3/8" x 1" Pin, Upper Jaw to Link, short (stainless steel)	2
6	16104-1SS	3/8" x 1.770" Pin, Upper Jaw Link (stainless steel)	6
7	1206	Spring, Jaw to Housing (stainless steel)	2
8	13009-1	Link, Jaw to Jaw (zinc)	4
8	13009-1SS	Link, Jaw to Jaw (stainless steel)	4
9	621	Fiber Drum Guard (Black Powder Coating)	2
9	621SS	Fiber Drum Guard (Stainless Steel)	2
10	15104-1SS	3/8" x 2.242" Pin, Fibre Guard, Housing to Clevis (stainless steel)	2
11	7019	3-7/8" Hair Pin Clip (zinc)	2
11	92391A210	18-8 Stainless Steel Cotter Pin, 18-8, Fits 7/8"-1", 3-3/4"	2
12	3006-CP	Cotter Pin, 1/8" x 3/4" (zinc)	16
12	1/8 x 3/4 CP-SS	1/8 x 3/4 Cotter Pins (stainless steel)	16
13	C616 FW-SS	C616 Flat Washer (stainless steel)	4
14	6012R	Universal Body (Black Powder Coating)	1
15	1/2-13 x 1 1/2 SHCS	1/2-13 x 1 1/2 Socket Head Cap Screw (zinc)	1
15	1/2-13 x 1 1/2 SHCS-SS	1/2-13 x 1 1/2 Socket Head Cap Screw (Stainless Steel)	1
16	1/2 LW	1/2 Lock Washer (zinc)	1
16	1/2 LW-SS	1/2 Lock Washer (stainless steel)	1
17	1/4-20 x 1 1/4 SHCS	1/4-20 x 1 1/4 Socket Head Cap Screw Alloy Plated	2
17	1/4-20 x 1 1/4 SHCS-SS	1/4-20 x 1 1/4 Socket Head Cap Screw (stainless steel)	2
18	1/4 LW	1/4 Lock Washer (zinc)	2
18	1/4 LW-SS	1/4 Lock Washer (stainless steel)	2
19	50064	Spacer (Black Powder Coating)	1
20	64061	Universal Pin (zinc)	1
20	64061-SS	Universal Pin (Stainless Steel)	1
21	50021R	Upper Pivot Block (Black Powder Coating - 5" Belt Cradle)	1
22	70062	Spring Roll Pins 1/4 X1-1/2 (zinc) (xref 70641)	1
22	1/4 x 1-1/2 SP-SS	1/4" x 1-1/2" Stainless Steel Spring Roll Pin	1
23	5012R	Lower Pivot Block with Oval Stop Bars (Black Powder Coating - 5" Belt Cradle)	1
24	8002	Adjustment Slide (FDA Black Powder Coating)	2
25	8996-2	Clevis Spring Hook (Stainless Steel)	1
26	10204-1SS	1/2" x 4-1/2" Adjusting Pin (stainless steel)	1
27	5912R	Upper Clevis 6" (Black Powder Coating - 5" Belt Cradle)	1
27	5912RZ	Upper Clevis 6" (FDA Powder Coating - 5" Belt Cradle)	1
28	6912R	Lower Clevis 5 1/2" (Black Powder Coating - 5" Belt Cradle)	1
28	6912RZ	Lower Clevis 5 1/2" (FDA Powder Coating - 5" Belt Cradle)	1
29	16033-1	1/2" x 2.625" Pin, Clevis (zinc)	2
29	EL.5-3SSH	1/2" x 3" Stainless Steel Pin - with cotter pin holes	2
30	6006-CP	Cotter Pin, 5/32" x 1" (zinc)	4
30	5/32 x 1 CP-SS	5/32 x 1 Cotter Pins (Stainless Steel)	4
31	8206	Clevis Spring (zinc)	2
32	50021RS	Upper Pivot Block (Black Powder Coating - 3" Belt Cradle)	1
33	5012RS	Lower Pivot Block (Black Powder Coat- 3" Belt Cradle)	1
34	5912RS	Upper Clevis 4 7/16" (Black Powder Coating - 3" Belt Cradle)	1
34	5912RZS	Upper Clevis 4 7/16" (FDA Powder Coating - 3" Belt Cradle)	1
35	6912RS	Lower Clevis 4" (Black Powder Coating - 3" Belt Cradle)	1
35	6912RZS	Lower Clevis 4" (FDA Powder Coating - 3" Belt Cradle)	1
36	HANG-1	3/16 x 1-1/4 Shank Lynch Pin "Hang 1" (9016)	1
36	HANG-1SS	3/16 x 1-1/4 Shank Lynch Pin "Hang 1" Stainless Steel	1

**FULL ASSEMBLIES**

4004R	EG2L Double Clamping Mechanism (Black Powder Coating - 5" Belt Cradle)
4004RS	EG2L Double Clamping Mechanism (Black Powder Coating - 3" Belt Cradle)
4004RSRC	EG2L Double Clamping Mechanism (Stainless Steel Housing - Spark Resistant - 5" Belt Cradle)
4004RSRC-S	EG2L Double Clamping Mechanism (Stainless Steel Housing - Spark Resistant - 3" Belt Cradle)
4004SS	EG2L Double Clamping Mechanism (FULL Stainless Steel - Spark Resistant - 5" Belt Cradle)
4004SS-S	EG2L Double Clamping Mechanism (FULL Stainless Steel - Spark Resistant - 3" Belt Cradle)

**PREVENTATIVE MAINTENANCE KITS**

EG2LPMKIT	EG2LDCM Preventative Maintenance Kit
EG2LSRCPMKIT	EG2LDCMSRC Preventative Maintenance Kit

**EG2 LIGHT DUTY DOUBLE CLAMPING MECHANISM  
PREVENTIVE MAINTENANCE KIT PARTS LIST**

**EG2LPMKIT - EG2L PREVENTATIVE MAINTENANCE KIT**

<u>ITEM</u>	<u>PART NO.</u>	<u>DESCRIPTION</u>	<u>QTY</u>
7	1206	Spring, Jaw to Housing (stainless steel)	2
11	7019	3-7/8" Hair Pin Clip (zinc)	2
12	3006-CP	Cotter Pin, 1/8" x 3/4" (zinc)	16
31	8206	Clevis Spring (zinc)	2
36	HANG-1	3/16 x 1-1/4 Shank Lynch Pin "Hang 1" (9016)	1
-	5516E	Optional: Belt Cradle Kit (3" wide x 23" long, includes all hardware)	1
-	B-800	White Lithium Grease Can	1

**EG2LSRCPMKIT - EG2LSRC PREVENTATIVE MAINTENANCE KIT**

	<u>PART NO.</u>	<u>DESCRIPTION</u>	<u>QTY</u>
7	1206	Spring, Jaw to Housing (stainless steel)	2
11	92391A210	18-8 Stainless Steel Cotter Pin, 18-8, Fits 7/8"-1", 3-3/4"	2
12	1/8 x 3/4 CP-SS	1/8 x 3/4 Cotter Pins (stainless steel)	16
31	8206	Clevis Spring (zinc)	2
36	HANG-1SS	3/16 x 1-1/4 Shank Lynch Pin "Hang 1" Stainless Steel	1
-	5516E	Optional: Belt Cradle Kit (3" wide x 23" long, includes all hardware)	1
-	B-800	White Lithium Grease Can	1

THIS PAGE INTENTIONALLY LEFT BLANK

# SCALE HARDWARE & WIRING FOR ERGO & EAGLE-GRIP STYLE MASTS ASSEMBLY

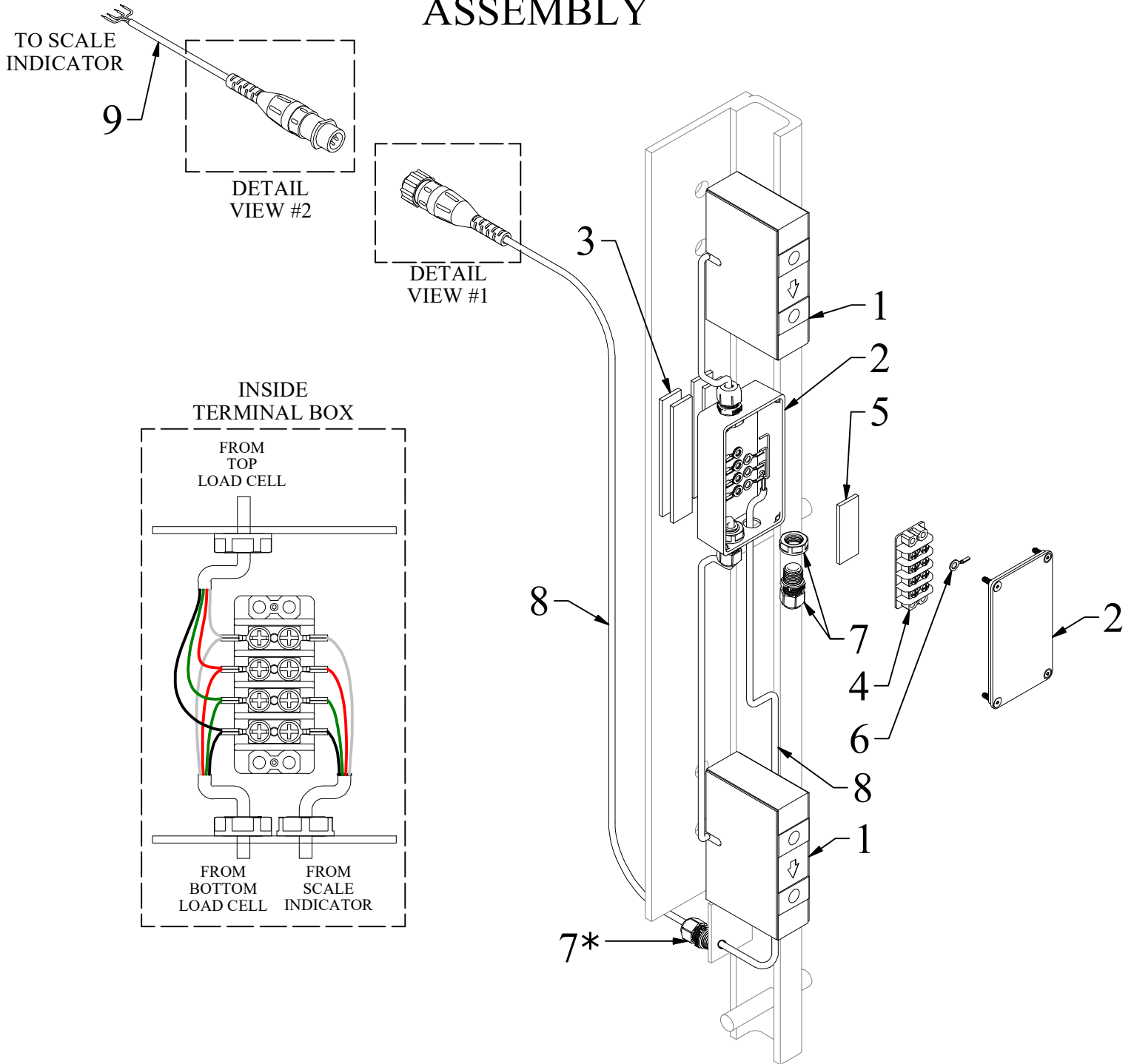

DETAIL VIEW #1 (MACHINE SIDE)

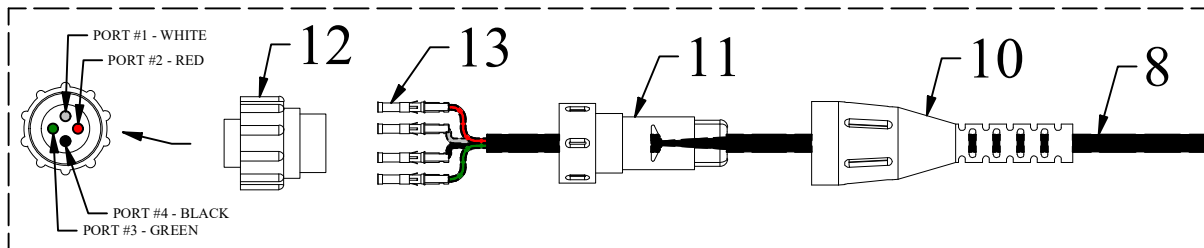

DETAIL VIEW #2 (SCALE SIDE)

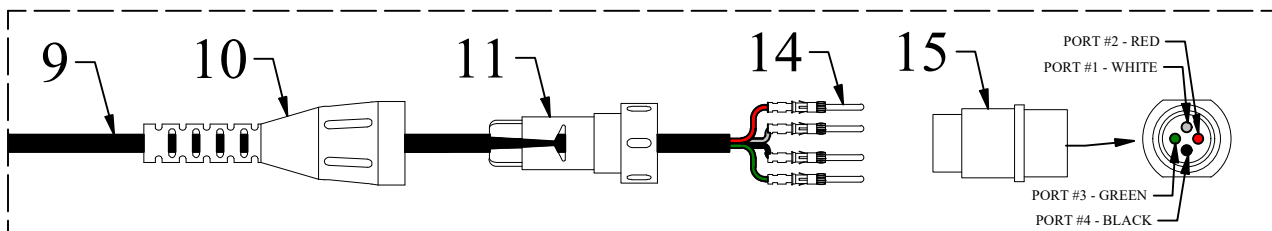

**SCALE HARDWARE & WIRING  
FOR ERGO AND EAGLE-GRIP MASTS  
PARTS LIST**

<b><u>ITEM</u></b>	<b><u>PART NO.</u></b>	<b><u>DESCRIPTION</u></b>	<b><u>QTY</u></b>
1	HM1000	Load Cell with 4' cable	2
2	CU-124	Terminal Box Enclosure	1
3	75315A34-4	Foam Tape, 2 sided adhesive, 3/4" X .125" x 4" length	4
4	7527K64	Terminal Block (Strip) 7/16", 4 circuits	1
5	75315A34-2	Foam Tape, 2 sided adhesive, 3/4" X .125" x 2" length	1
6	3A214	Terminal Eyelet	12
7	ZZHEY3208	Cable Fitting	4
8	3530359	Ergo Scale Cable Assembly (Female End) - 60" Length	1
8	3530360	Eagle-Grip Scale Cable Assembly (Female End) - 30" Length	1
9	3530361	Eagle-Grip/Ergo Scale Cable Assembly (Male End) - 24" Length	1
10	AP2074891	Strain Relief	2
11	AP2074901	Cable Grip	2
12	AP2060601	Connector Plug Size 11-4 (Female)	1
13	AP661054	Terminal Socket	4
14	AP661034	Terminal Pin	4
15	AP2061531	Connector Recp CPC 11-4 (Male)	1

\* Modified Strain Relief

**Non-Intrinsically Safe Indicators**

7000XLM	Doran® 7000XL Non-intrinsically Safe Scale Indicator
SUB0853	Rechargeable Battery, with wire and terminals (2200, 7000, 8000)
2200	Doran® 2200 Non-intrinsically Safe Scale Indicator (Numeric Keypad)
EXOPT319	Battery Option for Non-Intrinsically Safe 2200 Indicator
164582	Rice Lake®482 Indicator w Internal Battery & Charger
164585	Rice Lake®482 Plus Indicator w Internal Battery & Charger
107708	Rice Lake®720i Indicator

**Intrinsically Safe Indicators**

185288	Rice Lake®882IS Indicator w Battery Pack & Safe Area Charger
185291	Rice Lake®882IS PLUS Indicator w Battery Pack & Safe Area Charger
180831	Rice Lake®882IS Battery
194191	Rice Lake®882IS Battery Charger (IS6V2, 100-240 VAC)
72210052	Mettler Toledo IND226x Indicator ONLY
72258718	Mettler Toledo IND560x Indicator ONLY
64060627	Mettler Toledo EX Indicator Battery (Includes Cable)
64060217	Mettler Toledo Battery Charger (Safe Area, US Plug)

# EAGLE-GRIP, EL & MFCR SCALE BRACKET ASSEMBLY

## EL & MFCR SWIVEL BRACKET

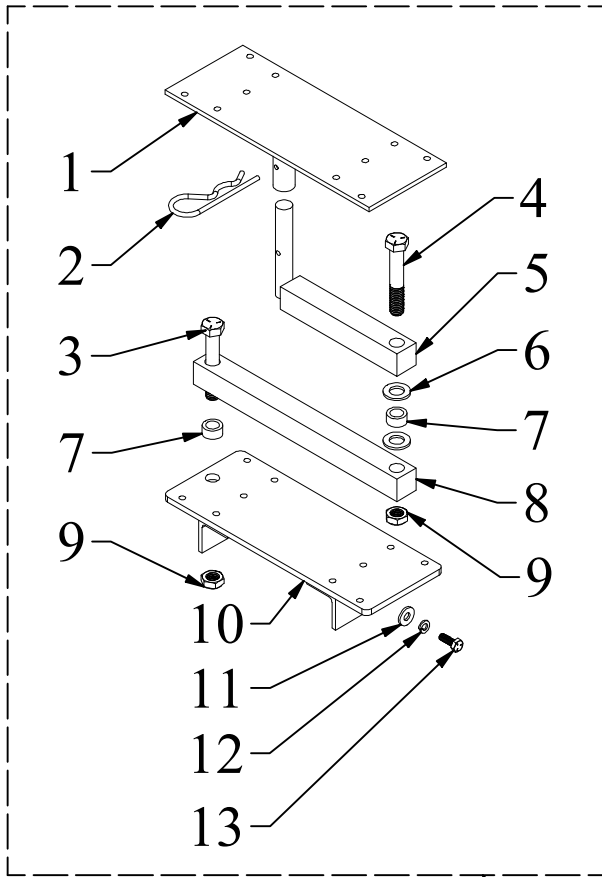

## EL ELEVATED RISER

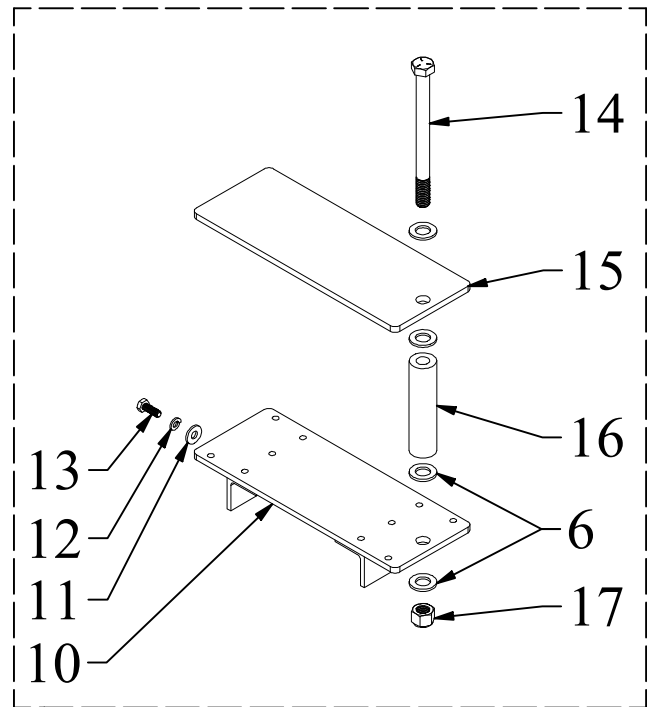

## EAGLE-GRIP SWIVEL BRACKET

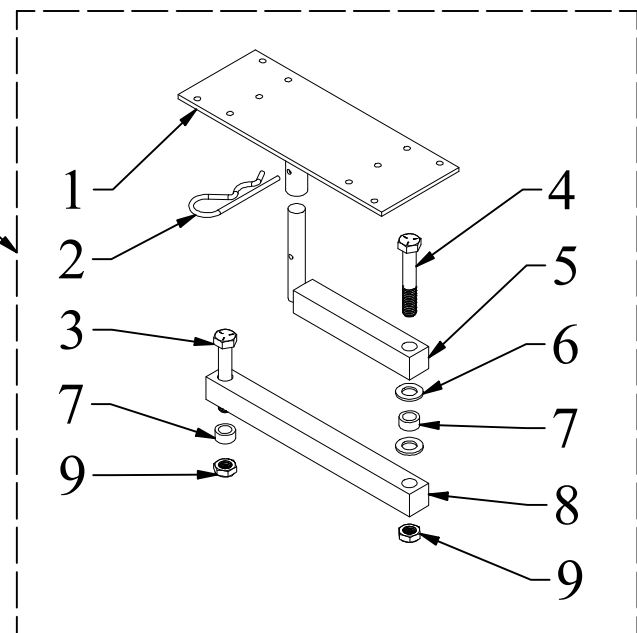

18  
19  
20

**EAGLE-GRIP, EL & MFCR  
SCALE BRACKET  
PARTS LIST**

<b><u>ITEM</u></b>	<b><u>PART NO.</u></b>	<b><u>DESCRIPTION</u></b>	<b><u>QTY</u></b>
1	3530348	Indicator Mount Bracket With Tube	1
2	98335A094	Zinc-plated steel cotter pin, 7/8"-1 D, 3-3/4 L	2
3	1/2-13 x 2 1/2 HHCS	1/2-13 x 2 1/2 Hex Head Cap Screw Grade 5 (zinc)	2
4	1/2-13 x 3 HHCS	1/2-13 x 3 Hex Head Cap Screw Grade 5 (zinc)	2
5	2580309	Scale Swing Bracket Post Bracket	2
6	1/2 FW	1/2 Flat Washer (zinc)	8
7	10001	Bushing, Housing Yolk Trunion (zinc)	4
8	2580308	Scale Swing Bracket Mid Bracket	2
9	1/2-13 THIN NLN	1/2-13 Nylon Locking Nut (THIN ZINC)	4
10	2580306	Ergo Scale Mount - 1.5" High	2
10	3530396	Ergo Scale Mount - 6.5" High	2
11	1/4 FW SAE	1/4 Flat Washer SAE (zinc)	4
12	1/4 LW	1/4 Lock Washer (zinc)	4
13	1/4-20 x 3/4 HHCS	1/4-20 x 3/4 Hex Head Cap Screw Grade 5 (zinc)	4
14	1/2-13 x 6 HHCS	1/2-13 x 6 Hex Head Cap Screw Grade 5 (zinc)	1
15	3530445	Elevated Scale Plate	1
16	3530446	Elevated Scale Plate Spacer	1
17	1/2-13 NLN	1/2-13 Nylon Locking Nut (zinc)	1
<b><u>FULL ASSEMBLY</u></b>			
18	3530447	Ergo Elevated Scale Plate Assembly	1
19	3530404	Ergo Scale Swing Out Bracket 1.5" Assembly	1
19	3530405	Ergo Scale Swing Out Bracket 6.5" Assembly	1
20	3530469	Eagle-Grip Scale Swing Out Bracket Assembly	1