

Easy Lift Equipment Co., Inc.

2 Mill Park Court, Newark, Delaware 19713 - Phone: 800-233-1800 / 302-737-7000

EASYLIFT DC POWERED COUNTERBALANCED DRUM TRANSPORTER WITH EG1 OR EG2L OPERATION & MAINTENANCE INSTRUCTIONS



EASYLIFT EQUIPMENT COUNTER-BALANCED DRUM TRANSPORTER

INTRODUCTION

The Counter-Balanced Drum Transporter is designed for lifting and moving drums/barrels in a wide variety of industrial settings. It can be used for loading and unloading drums from conventional wood, containment or “spill” pallets, cabinets, air piston pumps, and platform scales. The units vary in capacity up to 800 lbs. An assortment of options and modifications to suite the customers’ needs are also available.

All EasyLift drum transporters utilize an automatic clamping mechanism for handling any size steel or plastic chimed drum. These units vary in capacity from 100 to 800 pounds. The specification plate affixed to each unit provides the following information: model number, serial number, unit weight, and lifting capacity.

This manual contains information to instruct you on the proper use and maintenance of your Easy Lift Equipment unit. This manual should be available to all personnel working with the machine. Follow the maintenance procedures carefully to ensure a safe and reliable service life. Do not operate your equipment until you have read and understood these instructions.

COMISSIONING YOUR COUNTER BALANCED DRUM TRANSPORTER

1. Remove all packing materials, protective strapping, and wood shipping blocks.
2. Perform a visual inspection for component damage, including checking for hydraulic oil leaks, battery acid leaks, and electrical cord damage.
3. Open the DC cabinet and look for electrical components that may have been damaged or shifted during shipment. Inspect wires for tight connections.
4. Turn the master disconnect switch “ON” and observe the battery discharge indicator. The indicator should light up and display the green bar to the far right indicating a full charge.
5. Check that the lift and lower functions are working properly. Press the corresponding switches located on the top of the electrical cabinet, to ensure proper operation of each function.
6. Test the battery charger function by turning the master disconnect switch to “OFF” (DO NOT CHARGE THE UNIT IN THE “ON” POSITION). Insert a three-prong polarized heavy gauge extension cord rated 12-3 15amp / 125-volt extension cord (NOT PROVIDED) into the 110-volt AC socket located on the side of the DC cabinet. The charger should show a red LED light for each battery on the face of the battery charger and will start charging the batteries automatically. The LED lights signify the condition of each battery. The LED indicators will turn green when the batteries are fully charged.

NOTE: DO NOT OPERATE THE UNIT WHILE CHARGING OR WITH THE

EXTENSION CORD PLUGGED IN. 2

7. The battery discharge indicator on the side of the DC box (next to the master shut off switch) will be reset when the batteries reach a full charge of 2.35 volts per cell. This will be indicated by the solid green LED lights on the face of the battery charger. **“Reference the Pro Charge Battery Charger section of this manual for proper charging operations”**.

DAILY SAFETY INSPECTION

1. Perform a visual inspection, checking for any evident damage to unit and hydraulic oil leakage from previous use. Check all hydraulic connections and under the machine itself for leaks.
2. Open the DC cabinet and check to ensure the batteries are secure, clean, battery cables are connected and DC cable fuses are intact. Turn the master disconnect switch to the “ON” position. Ensure batteries have sufficient charge for operation. Do not operate the unit when the battery discharge indicator is at 70% depth of discharge or when the 2nd LED from the left is flashing as this could damage the internal components.
3. Check that the lift and lower functions are working properly. Press corresponding switches located on the top of the electrical cabinet, to ensure proper operation of each function.
4. Check to see the step-down floor lock is functioning properly and wheels are free of obstruction and functioning properly.

Do not operate your Ergonomic Drum Transporter if the unit does pass any part of the inspection. Tag the unit properly to keep it out of service until the problem has been corrected. Immediately report this condition to your supervisor.

SAFETY PRACTICES

1. Do not lift loads that exceed the unit’s rated capacity.
2. For transport, lift the drum just high enough so the drum has only the necessary floor clearance for travel. Do not transport or move a drum while the mast is raised to, or near, its maximum height.
3. Keep hands or feet away from the lifting area in front of the unit.
4. Keep hands or other objects clear of the lifting cylinder, clamping head, and moving mast during operation.
5. Ensure the lift cylinder rod is securely in place before lifting.
6. Never lay the unit down horizontally.

WARNINGS

- WARNING:** Do not lift or suspend loads over people. Stay clear of suspended loads.
- WARNING:** Do not attempt to overload the drum transporter beyond its rated capacity, or raise the drum beyond its maximum lifting height.
- WARNING:** Never move the drum transporter when the drum is at its maximum lifting height.
- WARNING:** Keep hands and feet away from the pinch points, mast channels, and clamping head.
- WARNING:** Do not make alterations or modifications to the unit without authorization from Easy Lift Equipment.
- WARNING:** Do not leave unit outside in rain, snow, etc., for extended periods.
- WARNING:** “For Manual Lift Models” Never press the release valve pedal too hard. It may cause the drum to lower too quickly and cause damage or injury.
- WARNING:** Never leave the unit without securing the unit with the step down floor lock. Failing to do so may allow the unit to roll by itself and cause property damage or personal injury.
- WARNING:** Never operate the unit on an incline or floor with a slope of more than 5°.
- WARNING:** Never wash the unit down. The unit is designed to be wiped down by hand. Washing down the unit may result in damage to the electrical components.
- WARNING:** “For DC Powered Lift Models” Do not operate the unit when the battery discharge indicator is at 70% depth of discharge (indicated by 2nd LED from the left on BDI is flashing) as this could damage the internal components.
- WARNING:** “For DC Powered Lift Models” Never perform any maintenance on the equipment unless the power cord is disconnected from the machine.
- WARNING:** Never perform any maintenance on the equipment unless the battery cables have been fully disconnected from the battery terminals.
- WARNING:** “For DC Powered Lift Models” Do not operate the unit while charging or with the extension cord plugged in.

DC POWERED COUNTER BALANCED ERGONOMIC DRUM TRANSPORTER OPERATING INSTRUCTIONS

TO ADJUST CLAMPING HEAD FOR VARIOUS DRUM HEIGHTS:

1. Remove the cotter & adjustment pin, and lower or raise the clamping mechanism so that the lower jaw is slightly below the chime of the drum. Then re-insert the adjustment & cotter pin into the desired location. It is recommended to have the cradle touching the lowest possible point of the drum that still permits engaging the drum. The second hole is positioned for use with standard 55-gallon drums.

TO ENGAGE AND TRANSPORT DRUMS:

1. Center the attachment clamping mechanism(s) with center of drum. Push the unit forward until the clamping mechanism contacts the drum.
2. Press the UP switch located on top of the electrical box to engage the clamping mechanism(s) with the chime of the drum. Apply a small amount of forward pressure to keep the clamp tight against the drum to ensure the clamping head grips the drum securely. The unit can now be pushed to transport the drum.
3. Press the DOWN switch located on top of the electrical box to lower the clamping mechanism and drum until the upper clamping jaw has retracted completely, disengaging the drum.

SCALE EQUIPPED MODELS (GRIP & WEIGH ATTACHMENTS)

If your equipment has a scale system, the indicator has already been calibrated and tested before leaving the factory. It has been disconnected and packaged separately for safe travel. Unpack the indicator from the box and mount to the unit on the provided mounting bracket. Connect the indicator cable to the unit cable by screwing the male and female ends together. Turn on the indicator and ensure it reads zero before engaging a drum or roll. If handling liquids in a drum, it may take up to one minute for the indicator to settle on a specific weight. To speed up this process it is recommended to set the to a lower sensitivity. This can be achieved by programming the indicator to read in .5 pounds or .25 kilograms. If set to read in 1.0 or .5 kg. increments it will take less time for the indicator to settle on a specific weight. Please refer to the manual of the specific indicator for proper operation instructions.

EASY LIFT DC POWERED COUNTERBALANCED DRUM TRANSPORTER

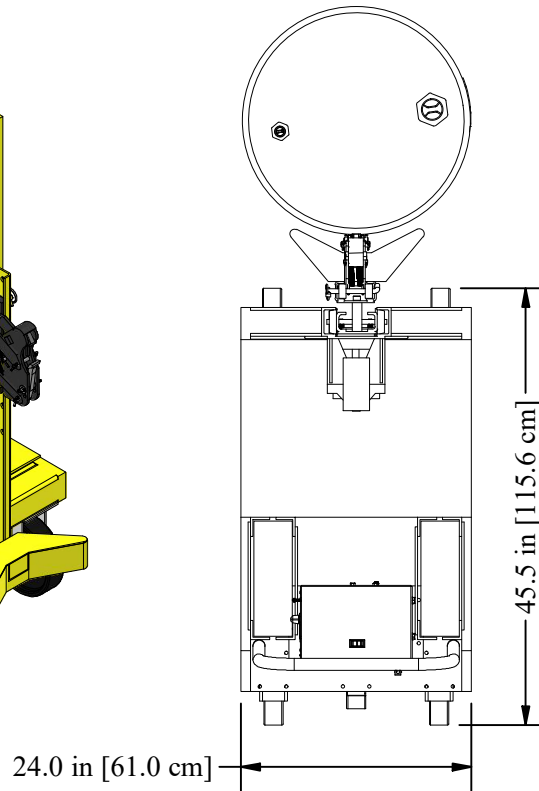
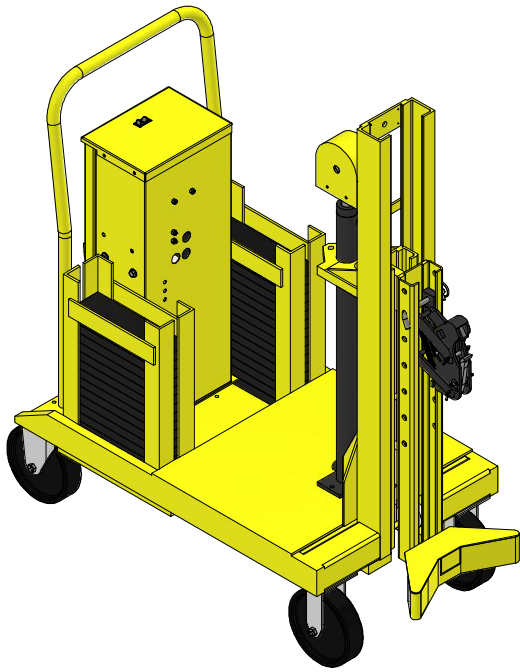

CAPACITY	COUNTERWEIGHT PER SIDE
400 lb [181 kg]	8
500 lb [227 kg]	10
600 lb [272 kg]	12
700 lb [318 kg]	14
800 lb [363 kg]	16

* Counterweight per side may vary based on equipment configuration

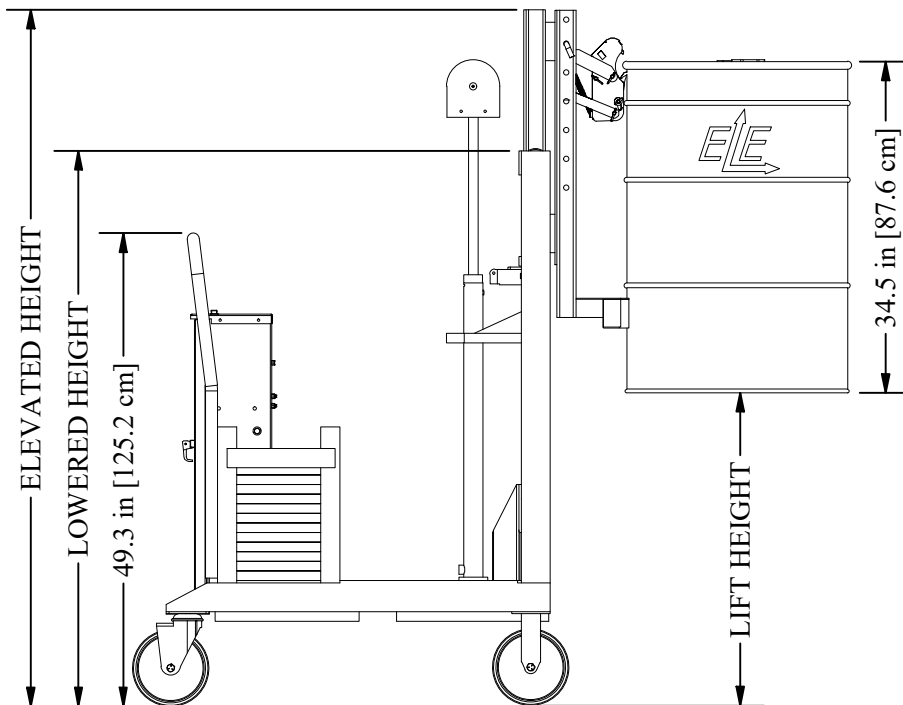

LIFT HEIGHT	LOWERED HEIGHT	ELEVATED HEIGHT
20 in [50.8 cm]	57.8 in [146.8 cm]	72.5 in [184.2 cm]
40 in [101.6 cm]	74.8 in [190.0 cm]	89.5 in [227.3 cm]
48 in [121.9 cm]	81.8 in [207.8 cm]	96.5 in [245.1 cm]
60 in [152.4 cm]	92.8 in [235.7 cm]	107.5 in [273.1 cm]
72 in [182.9 cm]	98.8 in [251.0 cm]	113.5 in [288.3 cm]
74 in [188.0 cm]	107.8 in [273.8 cm]	122.5 in [311.2 cm]

Easy Lift Equipment Co., Inc.

2 Mill Park Court, Newark, Delaware 19713 - Phone: 800-233-1800 / 302-737-7000

Operator's Daily Checklist

Drum Transporter (DC Powered) with Eagle-Grip® Clamp, V-Pan or Roll Post

Inspections Performed by: _____

Note: This inspection must be made by the equipment operator **daily** at the start of the shift. Check (✓) the appropriate "OK" or "Needs Repair" field.

This Daily Checklist is intended to help verify that the equipment is in proper working order each day.

More thorough Weekly, Monthly and Yearly Maintenance schedules should still be followed.

VISUAL CHECK		DATE: _____ / _____ / _____ / _____ / _____ / _____ / _____ / _____ / _____ / _____ / _____ / _____ / _____ / _____ / _____ / _____													
		OK	Needs Repair	OK	Needs Repair	OK	Needs Repair	OK	Needs Repair	OK	Needs Repair	OK	Needs Repair	OK	Needs Repair
VISUAL CHECK: FRAME & MAST	DATA PLATES & WARNING DECALS - Data Plates & Warning Decals are affixed to the unit and in good condition														
	DAMAGE - Look for bent, dented or broken parts. This includes hydraulic lines, electrical wires, frame welds, wheels, & bolted connections														
	LIFT CHAIN - Visually ensure lift chain is connected and not loose														
	LIFT CYLINDER - Ensure that the hydraulic lift cylinder and all lines are in operable condition														
	DC BOX - Ensure that the DC Box, as well as all controls, are in good condition with no visual damage														
	BATTERY & FUSES - Open the DC Box and visually ensure the battery cables & connections are in good condition & secure. Ensure DC cable fuses are intact														
	LEAKS - Check for any leaking oil, hydraulic fluid or battery acid														
	GUARDS - Verify that all chain guards are in place and in proper condition														
VISUAL CHECK: EAGLE CLAMP	CLAMP DAMAGE - Look for bent, dented or broken clamp components. This includes the clamp housing, the upper and lower clamping jaws, retaining pins, cotter pins, and springs														
	CLAMP PINS - Confirm that all retaining pins and cotter pins are accounted for and secure														
VISUAL CHECK: V-PAN OR ROLL POST	V-PAN/ROLL POST DAMAGE - Look for bent, dented or broken components. This includes all welds and bolted connections of both the V-Pan assembly and the Roll Post and mounting receiver, including all applicable safety pins, retaining pins, latching pins and cotter pins														
	V-PAN/ROLL POST PINS - Confirm that all applicable safety pins, retaining pins and cotter pins are accounted for and secure														
VISUAL: SCALE	SCALE SYSTEM & PRINTER - If applicable, confirm that the scale and printer as well as all wires, and cables are in good condition and properly connected														

Checklist Continued on Next Page

Easy Lift Equipment Co., Inc.

2 Mill Park Court, Newark, Delaware 19713 - Phone: 800-233-1800 / 302-737-7000

Operator's Daily Checklist (cont.)

Drum Transporter (DC Powered) with Eagle-Grip® Clamp, V-Pan or Roll Post

OPERATIONAL CHECK		DATE: / / / / / / / / / / / / / / / /													
		OK	Needs Repair	OK	Needs Repair	OK	Needs Repair	OK	Needs Repair	OK	Needs Repair	OK	Needs Repair	OK	Needs Repair
OPERATIONAL CHECK: FRAME & MAST	POWER UP - Turn on the Master Disconnect Switch on the DC Box. Ensure Power is supplied to the unit and the Battery Discharge Indicator lights are in proper working order														
	FOOT FLOOR LOCK - Verify that the Foot Floor Lock engages and disengages properly														
	WHEELS AND TRAVEL - Confirm that the unit travels properly. Ensure that the wheels are aligned properly, unobstructed, and not damaged														
	CONTROLS - Verify that both the lift and lower functions on the top of the DC Box are in proper working order														
	MAST - Ensure the clamping head, V-Pan or Roll Post moves smoothly up and down the mast, with no obstruction or unusual noises														
EAGLE-GRIP	EAGLE-GRIP CLAMPING HEAD - Verify that the Eagle-Grip Clamping Head engages and disengages a drum properly. Only lift the "test" drum to the minimum height required while completing this test														
V-PAN OR ROLL POST	V-PAN/ROLL POST FUNCTION - Verify proper function of all V-Pan or Roll Post components, including smooth rotation of the Stainless Steel V-Pan tray (if applicable), as well as proper operation of Roll Post rollers and/or folding capabilities (if applicable)														
SCALE & PRINTER	SCALE SYSTEM & PRINTERS - If applicable, power up the scale and printer. Ensure the scale and printer are in proper working order														

List the details of all required repairs in the comments section below. Then, **tag and decommission the equipment for safety.**

Comments (items needing repair or adjustment): _____

Caution – If the equipment is found to be in need of repair or in any way unsafe, or contributes to an unsafe condition, the matter shall be reported immediately to the designated supervisor, and the equipment shall not be operated until it has been restored to a safe operating condition. If during operation, the equipment becomes unsafe in any way, the matter shall be reported immediately to the designated supervisor, and the equipment shall not be operated until it has been restored to safe operating condition. Do not make repairs or adjustments unless specifically authorized to do so.

Easy Lift Equipment Co., Inc.

2 Mill Park Court, Newark, Delaware 19713 - Phone: 800-233-1800 / 302-737-7000

EASY LIFT EQUIPMENT WARRANTY POLICY FOR MODELS WITH PREFIXES: ED/ER/EL/ELDR/EG & RCR

Easy Lift Equipment (“ELE”) warrants each new product to be free from factory material and workmanship defects, under normal use with proper maintenance, for a period of 12 months. Warranty coverage for this warranty period is provided by authorized dealers and includes parts. Labor is covered for the same periods of 12 months as outlined above. Please call ELE for the authorized repair dealer in your area.

ELE shall be the sole judge of the validity of any claim or defect and may elect to make any replacement or repair of any part thereof that it has agreed to be defective. Wearable Items such as: hoses, bearings, belts, brushes, seals, lift motors, clamp motors, relays, fuses, springs and wheels are wear items not covered under the warranty policy. ELE assumes no responsibility whatsoever to work done, parts replaced, or expenses incurred not specifically authorized by ELE. Normal maintenance or replacement of service items is not covered by this warranty. No warranty claims will be considered for customers with any delinquent outstanding balance. When batteries, battery chargers, scale printers or scale indicators are purchased from ELE with the equipment, the original manufacturer’s warranty applies.

WARRANTY LIMITATION/DISCLAIMERS:

Easy Lift Equipment reserves the right to void warranty coverage if the unit has been overloaded beyond rated capacity; damaged due to: abuse, misuse, neglect, accidents, freight damage, improper usage, improper repair, and/or improper storage; or any modification or repair conducted in a manner not approved by Easy Lift Equipment. Equipment used in freezers, abrasive, corrosive, and/or excessively moist conditions must be properly equipped for the environment to ensure the warranty is not voided. Warranty questions and claims should be directed to our customer service department. ELE customer service representatives will help you assess and resolve the claim or assist you in contacting the local authorized dealer or representative. The warranty described here shall constitute the sole remedy of the authorized dealer and/or the initial purchaser. ELE neither assumes nor authorizes any person to assume for it any other obligation or responsibility in connection with this product warranty. In no event shall ELE be responsible for direct, indirect, special or consequential damages or any other delay or any economic or commercial loss resulting from Easy Lift Equipment’s performance or non-performance under this warranty. This warranty is expressly in lieu of all warranties, obligations or responsibilities of ELE dealers or other authorized source, expressed, implied or statutory.

SUBMITTING CLAIMS:

To make a claim under this policy, please contact Easy Lift Equipment for assistance. We can be reached by calling 800-233-1800 ext. 4 for customer service or by writing to sales@easylifteqpt.com. Do not return defective parts unless a return authorization (RA) has been provided requesting the return. If requested, we will provide shipping information on how the part should be returned and bear the expense for the return shipping, if the part is proven to be defective. A copy of the work order made at the time of the repair and parts claimed under warranty may be requested for ELE’s inspection.

ORDERING PARTS:

Easy Lift Equipment’s parts are distributed through our customer service department and ship the same day as ordered whenever possible. You will be well taken care of whenever parts, adjustments or repairs are needed. **When contacting ELE, please be sure to state the model and serial number for the equipment.** There is no cost for electronic copies of replacement manuals, parts lists and other general information containing part numbers and nomenclature. Most manuals contain parts pricing, but it is not guaranteed to be valid as parts pricing can change at any time without notice. Any customer service representative can provide timely parts quotations upon request. Adherence to above procedure will save time and provide prompt assistance when it counts. You are of course always welcome to bring to us any questions, comments or recommendations pertaining to your Easy Lift Equipment products.

MANUFACTURER CONTACT INFORMATION:

Easy Lift Equipment Co., Inc.
2 Mill Park Ct.
Newark, DE 19713
Email: sales@easylifteqpt.com

Phone: 800-233-1800: 302-737-7000
Fax: 302-737-7333
Website: www.easylifteqpt.com

OPERATION



Display

- 1** Only when the battery is properly charged is the right-most LED lit.
- 2** As the battery's state-of-charge decreases, successive LEDs light up, only one on at a time.
- 3** The 2nd-from-left LED flashes, indicating "energy reserve" (70% depth of discharge).
- 4** The 2 left-most LEDs alternately flash, indicating "empty" (80% depth of discharge).

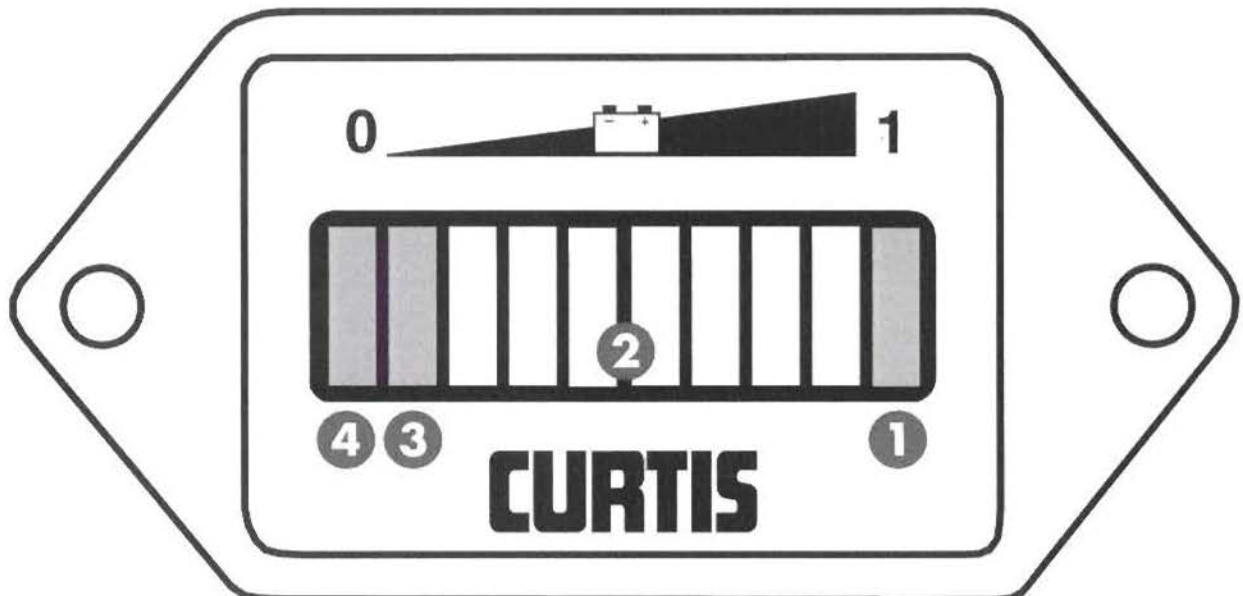

EASY LIFT EQUIPMENT FIBER DRUM EG1 CLAMPING PROCEDURE

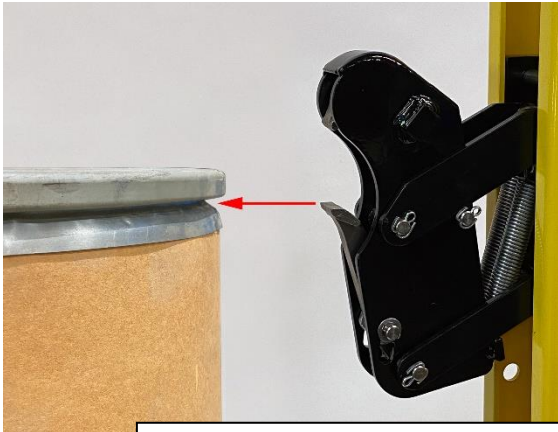

1. Raise the clamping mechanism until the lower jaw is just high enough to contact the metal skirt just below the locking band.

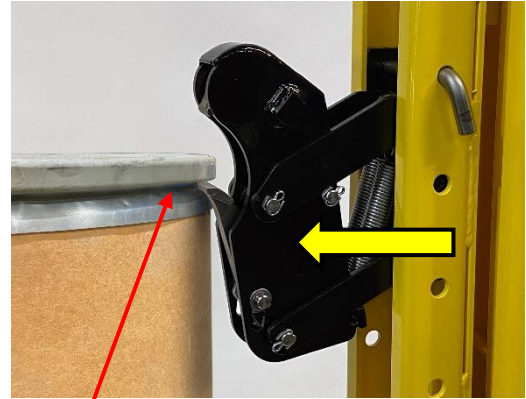

2. Then move the clamping mechanism forward so the lower jaw contacts the metal skirt under the drum's locking band and proceed to elevate the drum upward.



3. Maintain slight forward momentum while raising the drum so the lower clamping jaw maintains contact with the metal skirt. Do not allow the lower jaw to contact the paper portion of the fiber drum when elevating the drum.

IMPORTANT:

It is important that the lower jaw does not contact the paper portion of the drum when raising the clamping mechanism. Keep the lower jaw away from the paper portion of the drum until the lower jaw of the clamping mechanism is high enough to contact the metal skirt below the locking band.

Then push the clamping mechanism forward to contact the skirt. Once contact has been made, proceed to elevate the clamping mechanism. If the lower jaw contacts the paper portion of the drum when elevating the drum, the clamping mechanism will attempt to clamp the drum in this position and miss or tear the skirt. If this is done incorrectly, lower the clamp and try again. The clamping mechanism can also grip the drum without the lid and locking band.

EASY LIFT EQUIPMENT FIBER DRUM EG2L CLAMPING PROCEDURE

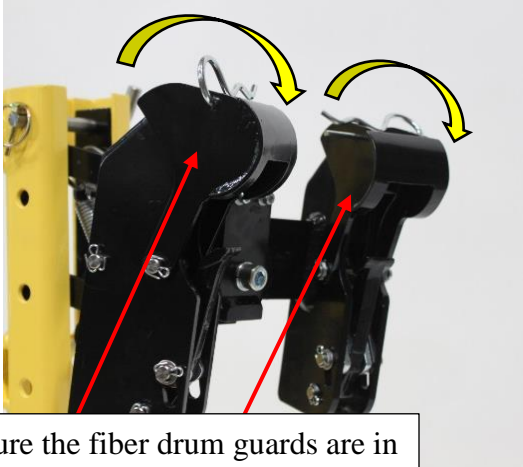

1. Ensure the fiber drum guards are in the forward position (closer to the clamp) and the cotter pins are locking the guards in place. The guards should always be in this position when handling fiber drums. The guards can be in the rearward position (closer to the mast) when handling steel or plastic drums.

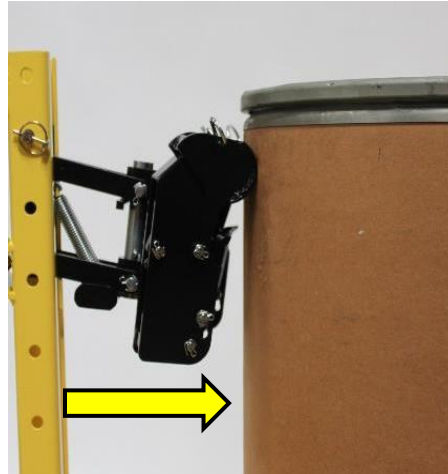

2. Push the unit forward so the fiber drum guards are contacting the paper portion of the drum.

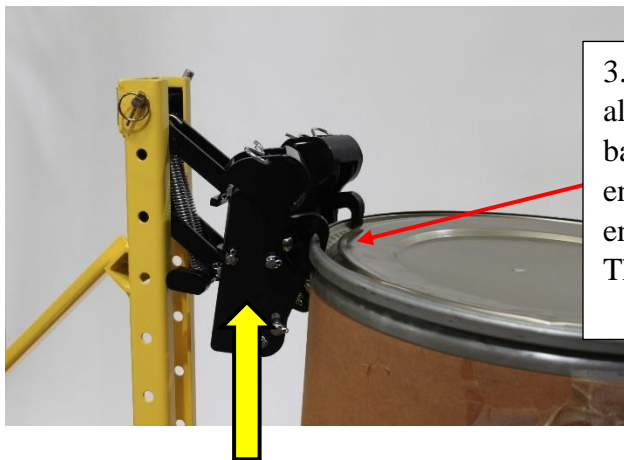

3. Elevate the clamping mechanism(s), allowing them to engage the locking band. After the clamp has fully engaged continue elevating the drum enough to ensure safe floor clearance. The drum can now be transported.

IMPORTANT:

The fiber drum guards, when in the forward position, are designed to prevent the clamp from damaging the fragile paper portion of fiber drums. Great care should still be taken to ensure the clamping mechanism only contacts the metal skirt and locking band.

THIS PAGE INTENTIONALLY LEFT BLANK

EASYLIFT COUNTERBALANCE DRUM TRANSPORTER FRAME ASSEMBLY

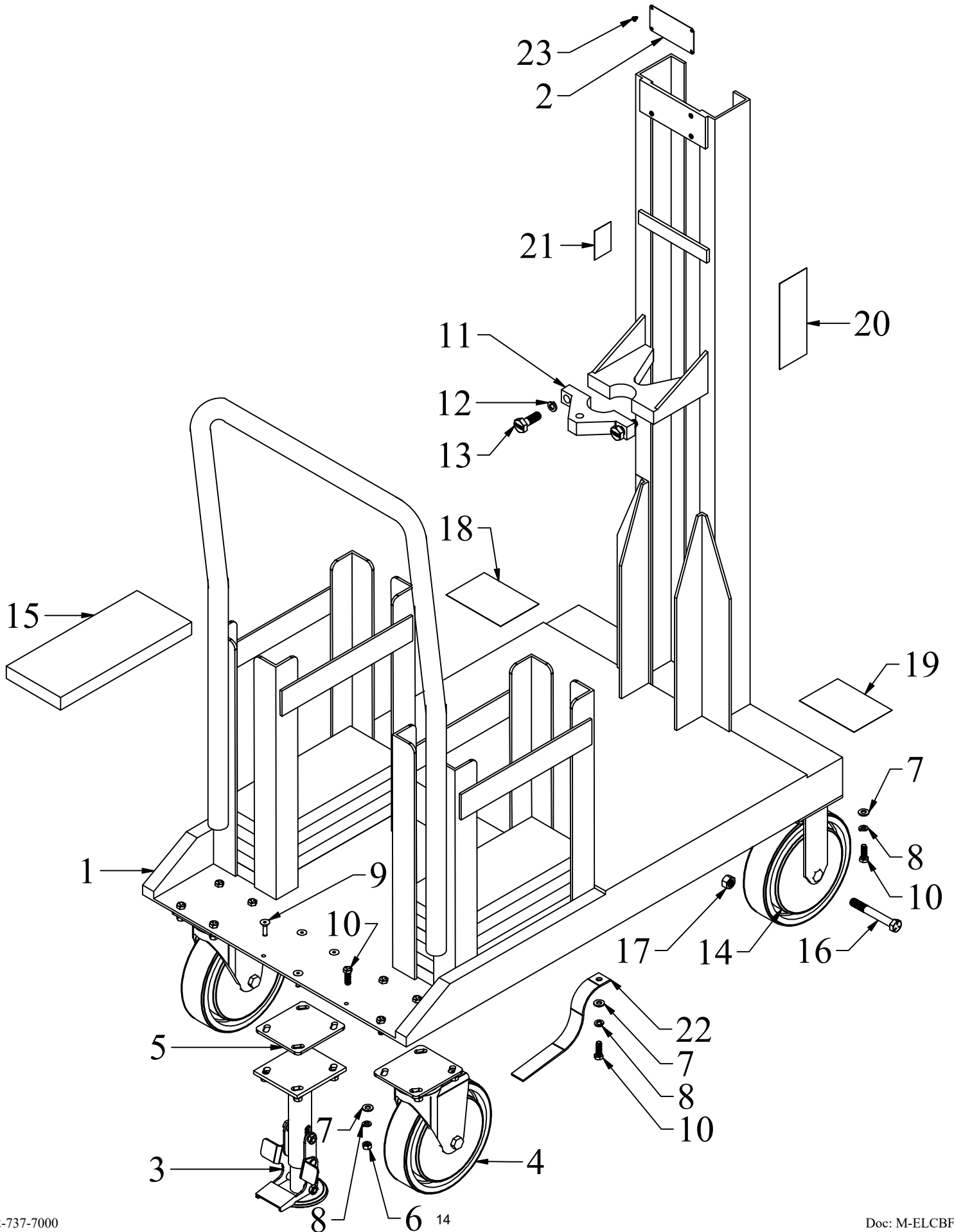

EASYLIFT COUNTERBALANCE DRUM TRANSPORTER FRAME PARTS LIST

<u>ITEM</u>	<u>PART NO.</u>	<u>DESCRIPTION</u>	<u>QTY</u>
1	3530145	Frame - Contact Easy Lift Equipment for Specifications	1
2	MCL007031	Specification Plate	1
3	16LF0880	Step Down Floor Lock (for 8" wheels)	1
4	31-408-PSE	8" Swivel Caster with PSE Wheel	2
-	W-408-PSE	8" PSE Wheel Only	-
5	28Z17SP	1/4" Shim Plate (zinc plated)	1
6	5/16-18 HN	5/16-18 Finished Hex Nut (zinc)	12
6	5/16-18 HN-SS	5/16-18 Finished Hex Nut (stainless steel)	12
7	5/16 FW	5/16 Flat Washer (zinc)	21
7	5/16 FW-SS	5/16 Flat Washer (stainless steel)	21
8	5/16 LW	5/16 Lock Washer (zinc)	21
8	5/16 LW-SS	5/16 Lock Washer (stainless steel)	21
9	5/16-18 x 1 1/4 FSHCS-SS	5/16-18 x 1 1/4 Flat Socket Head Cap Screw (stainless steel)	4
10	5/16-18 x 1 HHCS	5/16-18 x 1 Hex Head Cap Screw Grade 5 (zinc)	17
10	5/16-18 X 1 HHCS-SS	5/16-18 x 1 Hex Head Cap Screw (stainless steel)	17
11	35091	Cylinder Clamp Bracket	1
11	35091-40	High Lift Cylinder Clamp Bracket	1
12	1/2 LW	1/2 Lock Washer (zinc)	2
12	1/2 LW-SS	1/2 Lock Washer (stainless steel)	2
13	1/2-13 x 1 1/2 HHCS	1/2-13 x 1 1/2 Hex Head Cap Screw Grade 5 (zinc)	2
13	1/2-13 x 1 1/2 HHCS-SS	1/2-13 x 1 1/2 Hex Head Cap Screw (stainless steel)	2
14	31-408R-PSE	8" Rigid Caster with PSE Wheel	2
-	W-408-PSE	8" PSE Wheel Only	-
15	1" x 5" x 12" HRFB CW	1" x 5" x 12" HRFB CB Counter Weight	-
15	1" x 4" x 12" HRFB CW	1" x 4" x 12" HRFB DC CB Counter Weight	-
16	1/2-13 x 3 3/4 HHCS	1/2-13 x 3 3/4 Hex Head Cap Screw Grade 5 (zinc)	4
16	1/2-13 x 3 3/4 HHCS-SS	1/2-13 x 3 3/4 Hex Head Cap Screw (stainless steel)	4
17	1/2-13 HN	1/2-13 Finished Hex Nut (zinc)	4
17	1/2-13 HN-SS	1/2-13 Finished Hex Nut (stainless steel)	4
18	ADART002	Attention Read Operations Manual Decal	1
19	ADART003	Weight Capacity (Use Weight, 600 lb Example "ADART600")	1
20	ADART016	ELE Address Decal (Vertical)	2
21	ADART009	Warning 5 Degree Decal for ELE & EL	1
22	S-207	Grounding Strap	1
23	6 x 1/4 RUDS-SS	6 x 1/4 Round Head U Drive Screw (stainless steel)	4

INNER MAST ASSEMBLY

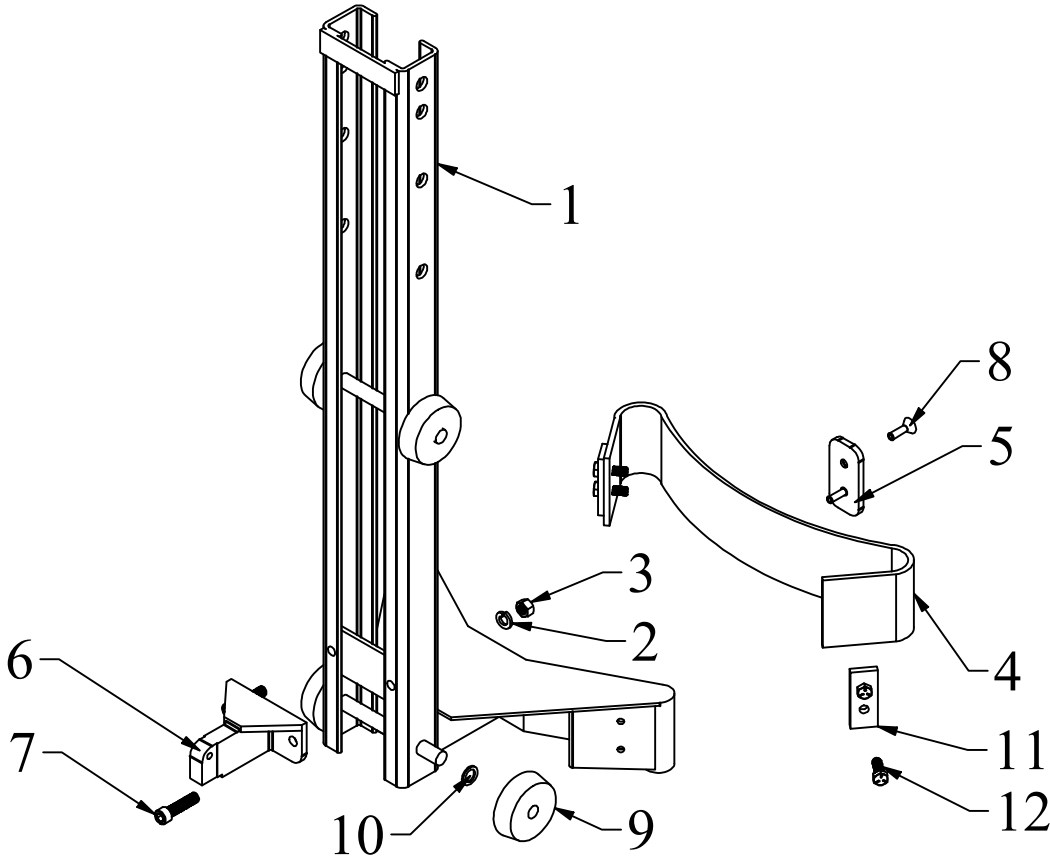

INNER AND OUTER MAST ASSEMBLY

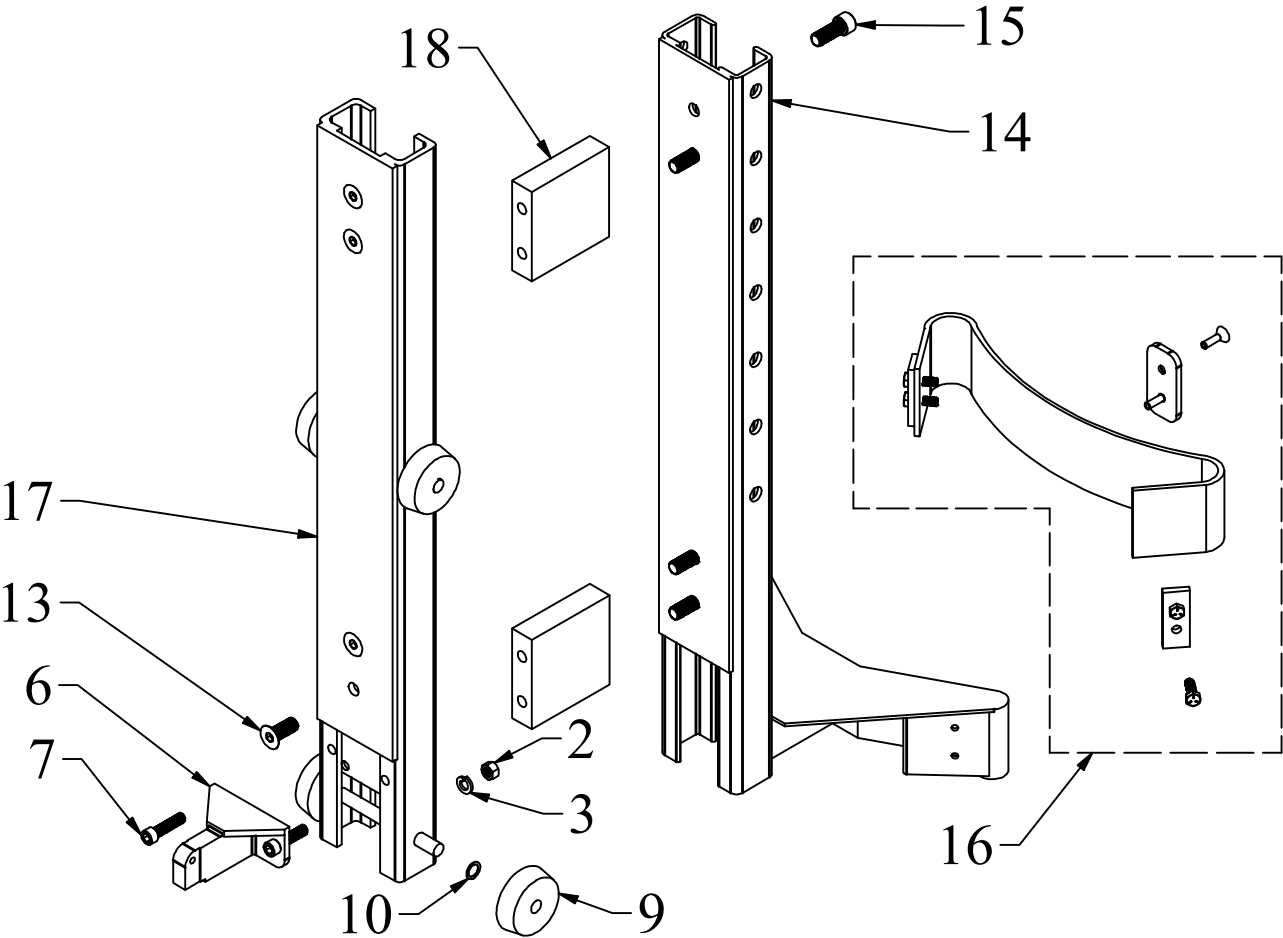

INNER MAST PARTS LIST

<u>ITEM</u>	<u>PART NO.</u>	<u>DESCRIPTION</u>	<u>QTY</u>
1	3912	32" High Inner Mast with 5" Belt Cradle	1
2	3/8-16 HN	3/8-16 Finished Hex Nut (zinc)	2
2	3/8-16 HN-SS	3/8-16 Finished Hex Nut (stainless steel)	2
3	3/8 LW	3/8 Lock Washer (zinc)	2
3	3/8 LW-SS	3/8 Lock Washer (stainless steel)	2
4	5516	Rubber Belt Only (3" wide x 23" long, no hardware)	1
5	2580051	EG1/Ergo UHMW Belt Support	1
6	8912	Chain to Mast Bracket	1
6	8912HR	High Reach Chain to Mast Bracket	1
7	3/8-16 x 1 1/2 SHCS	3/8-16 x 1 1/2 Socket Head Cap Screw Alloy Plated	2
7	3/8-16 x 1 1/2 SHCS-SS	3/8-16 x 1 1/2 Socket Head Cap Screw (stainless steel)	2
8	5/16-18 x 1 FSHCS-SS	5/16-18 x 1 Flat Socket Head Cap Screw (stainless steel)	6
9	4008	Delrin Roller	4
10	90295A187	1/16" Nylon Flat Washer	-
10	95606A170	1/32" Nylon Flat Washer	-
11	2580050	EG1/Ergo Belts Clamp Straps	2
12	5/16-18 X 1 HHCS	5/16-18 x 1 Hex Head Cap Screw Grade 5 (zinc)	4
12	5/16-18 X 1 HHCS-SS	5/16-18 x 1 Hex Head Cap Screw (stainless steel)	4

INNER AND OUTER MAST PARTS LIST

<u>ITEM</u>	<u>PART NO.</u>	<u>DESCRIPTION</u>	<u>QTY</u>
2	3/8-16 HN	3/8-16 Finished Hex Nut (zinc)	2
2	3/8-16 HN-SS	3/8-16 Finished Hex Nut (stainless steel)	2
3	3/8 LW	3/8 Lock Washer (zinc)	2
3	3/8 LW-SS	3/8 Lock Washer (stainless steel)	2
6	8912	Chain to Mast Bracket	1
6	8912HR	High Reach Chain to Mast Bracket	1
7	3/8-16 x 1 1/2 SHCS	3/8-16 x 1 1/2 Socket Head Cap Screw Alloy Plated	2
7	3/8-16 x 1 1/2 SHCS-SS	3/8-16 x 1 1/2 Socket Head Cap Screw (stainless steel)	2
9	4008	Delrin Roller	4
10	90295A187	1/16" Nylon Flat Washer	-
10	95606A170	1/32" Nylon Flat Washer	-
13	1/2-20 x 1 1/4 FSHCS	1/2-20 x 1 1/4 Flat Socket Head Cap Screw (zinc)	4
14	2580453	32" High Outer Mast with 3" Belt Cradle	1
14	2580459	32" High Outer Mast with 5" Belt Cradle	1
15	1/2-20 x 1 1/4 SHCS	1/2-20 x 1 1/4 Socket Head Cap Screw Alloy Plated	4
16	5516E	Optional: Belt Cradle Kit (3" wide x 23" long, includes all hardware)	1
17	2580401	32" High Inner Mast (Scale)	1
18	LCRB	Load Cell Replacement Block	2
18	HM1000	Load Cell with 4' cable	2

COUNTERBALANCE DRUM TRANSPORTER LIFT CHAIN ASSEMBLY

COUNTERBALANCE FOOT PUMP MODELS
GREATER THAN STANDARD 20" LIFT

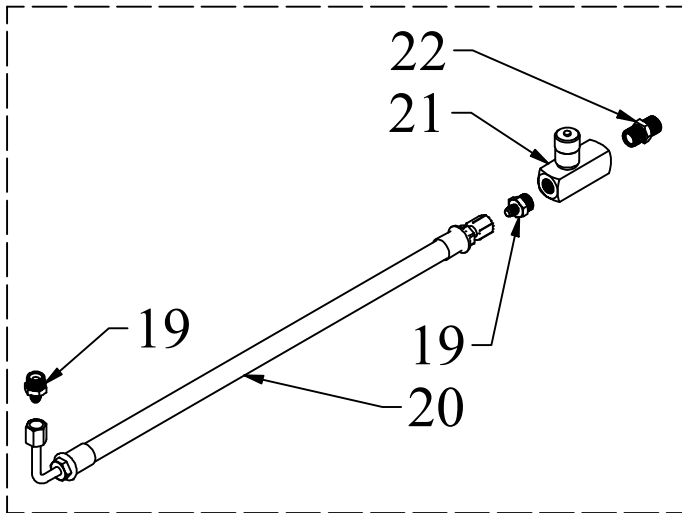

COUNTERBALANCE FOOT PUMP MODELS
WITH STANDARD 20" LIFT

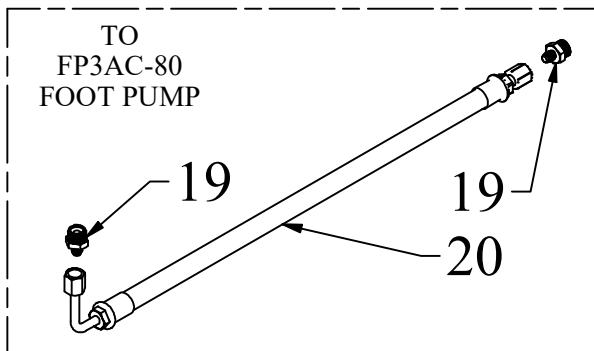

COUNTERBALANCE DC ONLY

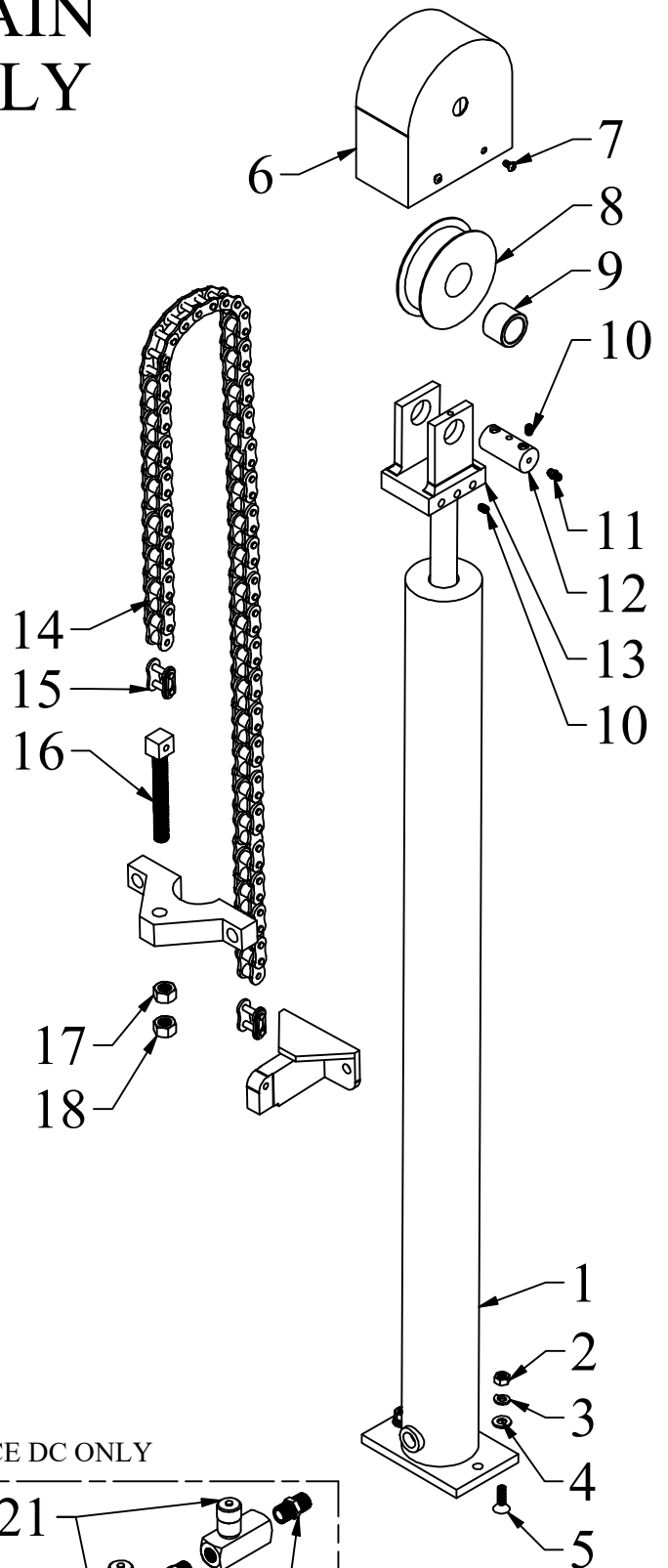
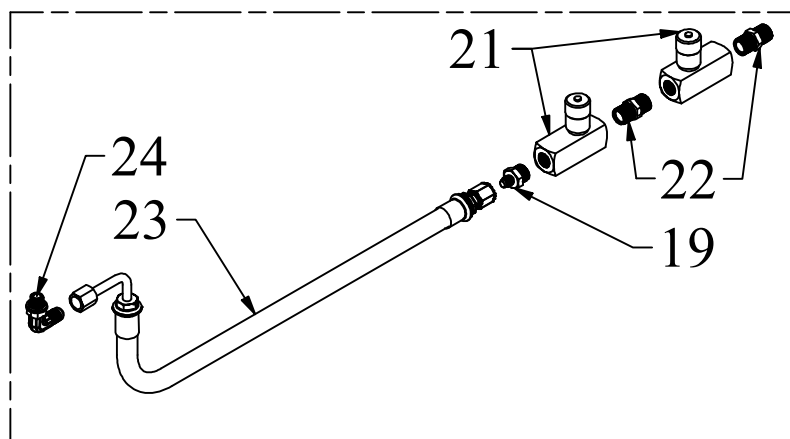

COUNTERBALANCE DRUM TRANSPORTER LIFT CHAIN PARTS LIST

<u>ITEM</u>	<u>PART NO.</u>	<u>DESCRIPTION</u>	<u>QTY</u>
1	EL1.5-1.0-24BZ	Hydraulic Lift Cylinder	1
1	EL1.5-1.0-28BZ	Hydraulic Lift Cylinder	1
1	EL1.5-1.0-32BZ	Hydraulic Lift Cylinder	1
1	EL1.5-1.0-36BZ	Hydraulic Lift Cylinder	1
1	EL1.5-1.0-40BZ	Hydraulic Lift Cylinder	1
-	EL1.5PISTONKIT	Seal Kit (new piston, seals & wire)	-
2	5/16-18 HN	5/16-18 Finished Hex Nut (zinc)	2
2	5/16-18 HN-SS	5/16-18 Finished Hex Nut (stainless steel)	2
3	5/16 LW	5/16 Lock Washer (zinc)	2
3	5/16 LW-SS	5/16 Lock Washer (stainless steel)	2
4	5/16 FW	5/16 Flat Washer (zinc)	2
4	5/16 FW-SS	5/16 Flat Washer (stainless steel)	2
5	5/16-18 x 1 1/4 FSHCS-SS	5/16-18 x 1 1/4 Flat Socket Head Cap Screw (stainless steel)	2
6	3022	4" Sheave Wheel Cover	1
7	10-24 x 3/8 BSC-SS	10-24 x 3/8 Button Socket Cap 18/8 (stainless steel)	4
8	55061	4" Sheave Wheel	1
9	CB-1622-08	Sheave Wheel Bushing	1
10	93445A425	1/4"-20 x 3/8" Stainless Steel Knurl-Grip Set Screw	2
11	1095K41	1/4"-28 Grease Fitting	1
12	45061	Sheave Wheel Axle (1" x 2.125")	1
13	7912-4-1	Sheave Wheel Bracket 4" (1" bore)	1
14	RC060RC1-49	Chain-Ansi 60 (49" Long)	1
14	RC060RC1-49PC	FDA Chain-Ansi 60 (49" Long)	1
14	RC060RC1-65	Chain-Ansi 60 for Ergo (65" Long)	1
14	RC060RC1-65PC	FDA Chain-Ansi 60 for Ergo (65" Long)	1
14	RC060RC1-73	Chain-Ansi 60 for Ergo (73" Long)	1
14	RC060RC1-73PC	FDA Chain-Ansi 60 for Ergo (73" Long)	1
15	60HMCL	ANSI 60 Link	2
15	ARC060SCL1	FDA ANSI 60 Link	2
16	2022	Chain Adjuster for ANSI 60 Chain	1
17	1/2-13 HN	1/2-13 Finished Hex Nut (zinc)	1
17	1/2-13 HN-SS	1/2-13 Finished Hex Nut (stainless steel)	1
18	1/2-13 NLN	1/2-13 Nylon Locking Nut (zinc)	1
18	1/2-13 NLN-SS	1/2-13 Nylon Locking Nut (Stainless Steel)	1
19	6-6 FTX-S	# Male Connector	2 / 1
20	487TC-6-F-G-20	20" long 3/8" Hydraulic Hose w/ (1) Female Swivel Straight & (1) Female 90D ends	1
21	F600B	## Flow Control 3/8" NPT	1 / 2
22	3/8 FF-S	## Hex Nipple 3/8"	1 / 2
23	487TC-6-F-I-21	21" long 3/8" Hydraulic Hose w/ (1) Fml Swvl St. & (1) Fml 90° Long Drop Elbow	1
24	6C4OMXS	* HPI 90 Deg Fitting (Post 2013)	1
24	6-6 C4OMXS	** 90 Male Elbow 3/8 BSPP (for Rexroth Pump)	1

First quantity CB Foot Pump / Second quantity CB DC

First quantity CB Foot Pump greater than 20" of lift / Second quantity CB DC

* Fitting for HPI Pump

** Fitting for Rexroth Pump

LIFT ONLY DC CABINET WITH REXROTH PUMP & MASTER DISCONNECT HARDWARE ASSEMBLY

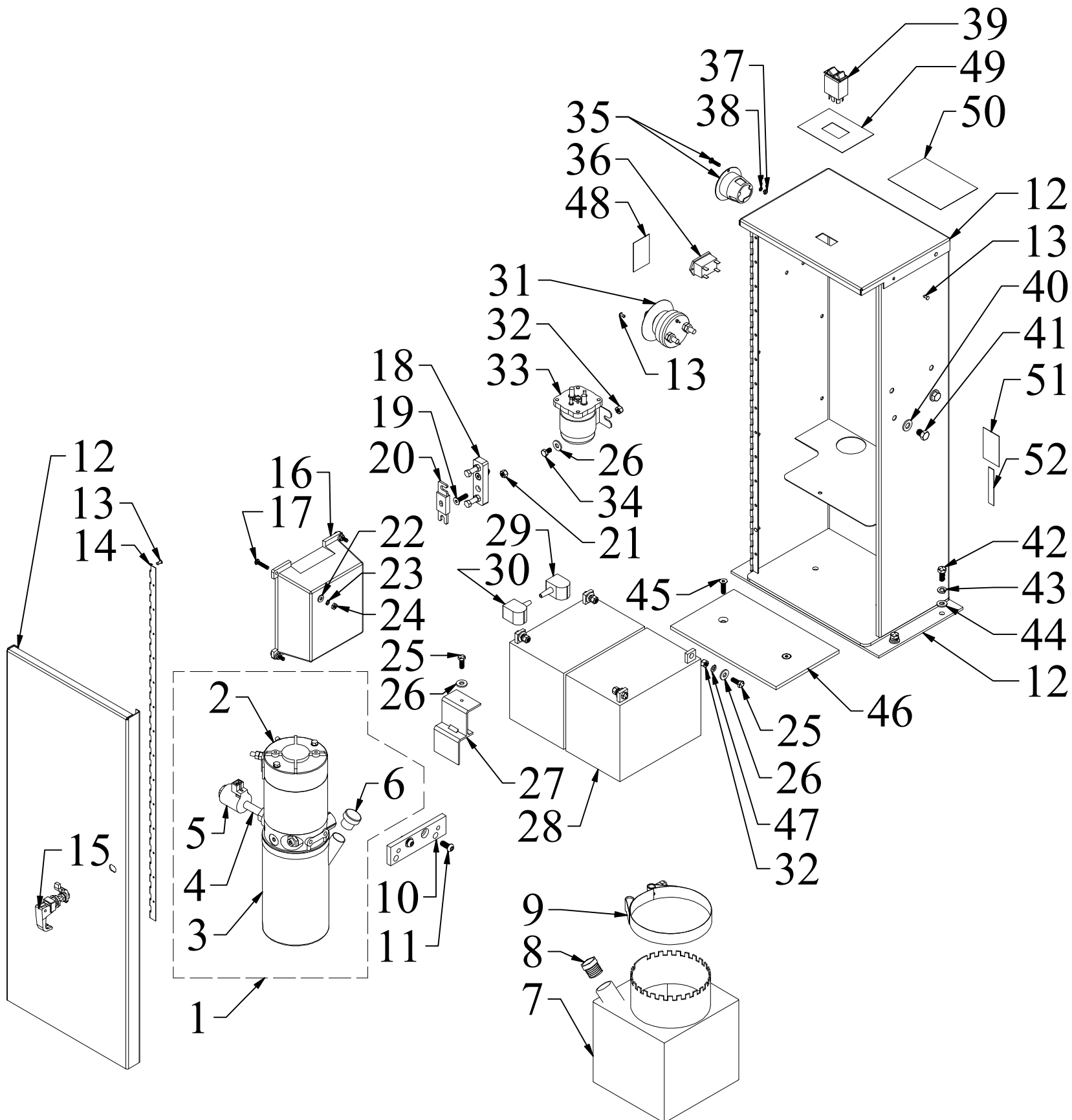

**LIFT ONLY DC CABINET WITH REXROTH PUMP
& MASTER DISCONNECT HARDWARE
PARTS LIST**

<u>ITEM</u>	<u>PART NO.</u>	<u>DESCRIPTION</u>	<u>QTY</u>
1	ELE51495653	Rexroth - Hydraulic Assy. with Elbow (Gen 1, DH s/n: C23051 to Present, EL Gen 4)	1
2	51637048	Pump Motor	1
3	51637055	Hydraulic Tank	1
4	51637057	Solenoid Valve	1
5	51599237	Magnetic Coil	1
6	51057393	Breather & Dip Stick	1
7	# DM106	Rexroth XL Hydraulic Tank	1
8	# 9833K11	1/2" Breather Vent	1
9	# 5204K16	Rexroth pump metal bolt clamp (4-9/32" to 4-19/32")	1
10	MM10001	2022 DC Box Pump Mounting bracket	1
11	M8-1.25 X 20MM BSHCS-A	M8-1.25 x 20mm Button Socket Head Cap Screw Alloy	2
12	3530233	EL or SL DC Cabinet w/ Welded Plate & 1 Hole Lid and Door	1
12	* DM021-2025	DC Cabinet 29 5/8" Tall w/o Welded Plate with 1 Hole Lid and Door	1
-	DM099	DC Cabinet Door	1
-	DM091	DC Cabinet One Hole Lid	1
13	97447A025	Aluminum Blind Rivet 1/8" for material .188-.25"	19
14	CS24010628H	Cabinet Hinge	1
15	S 62-10-23	Lift & Turn Latch	1
16	IS2	12 amp 2 bank 110/220/50-60/1ph CE Charger	1
-	7821055	AGC 30A Fuse (5 pack)	1
17	10-24 x 1 PMS-SS	10-24 x 1 Phillips Machine Screw (stainless steel)	4
18	4164	Limiter Fuse Block	1
19	1/4-20 x 1 FSHCS-SS	1/4-20 x 1 Flat Socket Head Cap Screw (stainless steel)	2
20	ANL-250	Fuse, 250A, Series ANL, 32VAC/80VDC	1
21	102672611	1/4-20 SS Acorn Nut	2
22	10 FW-SS	#10 Flat Washer 18/8 (stainless steel)	4
23	10 LW-SS	#10 Lock Washer 18/8 (stainless steel)	4
24	10-24 HN-SS	10-24 Finished Hex Nut 18/8 (stainless steel)	4
25	1/4-20 x 3/4 HHCS	1/4-20 x 3/4 Hex Head Cap Screw Grade 5 (zinc)	5
25	1/4-20 x 3/4 HHCS-SS	1/4-20 x 3/4 Hex Head Cap Screw (stainless steel)	5
26	1/4 FW SAE	1/4 Flat Washer SAE (zinc)	7
26	1/4 FW-SS	1/4 Flat Washer (stainless steel)	7
27	2580045	Battery Bracket	1
28	DCM0035L	12v DC 35Ah Deep Cycle Battery (List Price \$ 140.00, Limited time promo price)	2
29	DEK06119	Right Elbow Boot 4-8 GA Red	2
30	DEK06120	Left Elbow Boot 4-8 GA Black	2
31	PA16529	Master Disconnect Switch	1
32	1/4-20 NLN	1/4-20 Nylon Locking Nut (zinc)	6
32	1/4-20 NLN-SS	1/4-20 Nylon Locking Nut (stainless steel)	6
33	% 586-114111	Motor Solenoid 24 volt/200 amp Continuous Duty	1
34	1/4-20 x 1/2 HHCS-SS	1/4-20 x 1/2 Hex Head Cap Screw (stainless steel)	2
35	HBL5278C	120 volt A/C Receptacle (Male)	1
35	HBL5678C	220 volt A/C Receptacle (Male)	1
36	T101772	24 Volt Battery Discharge Indicator (906T24JWDGN)	1
37	9079	18-8 SST Hex Mach Screw Nuts 6-32	2
38	9098	18-8 SST Lock Washers Size #6	2
39	8555K32X32M	White Rocker Switch	1
40	3/8 LW-SS	3/8 Lock Washer (stainless steel)	2
41	3/8-16 x 1 HHCS-SS	3/8-16 x 1 Hex Head Cap Screw (stainless steel)	2
42	5/16-18 X 3/4 HHCS	5/16-18 x 3/4 Hex Head Cap Screw Grade 5 (zinc)	4
42	5/16-18 X 3/4 HHCS-SS	5/16-18 x 3/4 Hex Head Cap Screw (stainless steel)	4
43	5/16 LW	5/16 Lock Washer (zinc)	4
43	5/16 LW-SS	5/16 Lock Washer (stainless steel)	4
44	5/16 FW SAE	5/16 Flat Washer SAE (zinc)	4
44	5/16 FW SAE-SS	5/16 Flat Washer SAE (stainless steel)	4
45	* 1/4-20 x 1 FSHCS-SS	1/4-20 x 1 Flat Socket Head Cap Screw (stainless steel)	2
46	* 3530234	DC Cabinet Inner Mounting Plate (CB, ELDR, ED, ER)	1
47	1/4 LW	1/4 Lock Washer (zinc)	4
	<u>DECAL</u>	<u>DESCRIPTION</u>	
48	ADART025	120 Volts AC Warning Decal	1
48	ADART043	220 Volts AC Warning Decal	1
49	ADART007	Decal "Lift"	1
50	ADART028	Attention Operating Equipment While Charging Will Damage Decal	1
51	ADART042	"Attention Read Operations Manual Before Adjusting" Decal	1
52	ADART021	Flow Control Decal "UP/DOWN"	1
	<u>HYDRAULIC FLUID</u>	<u>DESCRIPTION</u>	
	AWG32	Hydraulic Oil AWG32	1
	FG32/46	Food Grade 32/46 Hydraulic Synthetic Lubricant	1

First used on A25032

* For Counterbalance Models Only

% New style Solenoid first used on E25015 (if sold as replacement for old style Solenoid, kit 3530550 or 3530552 will be required).

LIFT ONLY DC CABINET WITH REXROTH PUMP & MASTER DISCONNECT WIRING ASSEMBLY

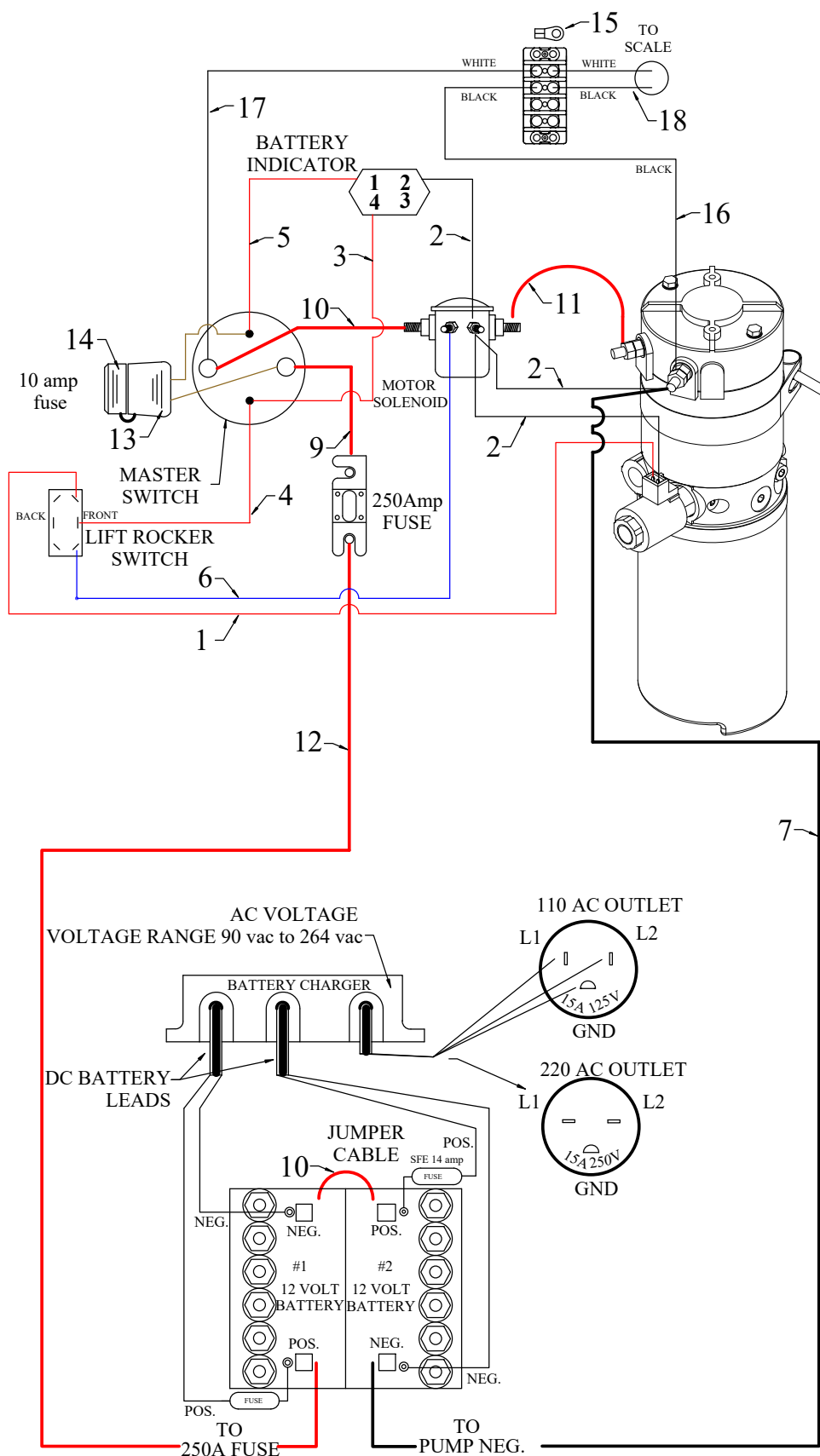

**LIFT ONLY DC CABINET WITH REXROTH PUMP
& MASTER DISCONNECT WIRING
PARTS LIST**

<u>ITEM</u>	<u>PART NO.</u>	<u>DESCRIPTION</u>	<u>QTY</u>
1	80094UZ-29-9	9" Signal Wire with (1) 16-14 .250 end	1
2	80097UZx3-29-84-80-06	(3) Lengths of Black Wire w/ PA80029, PA85884, PA85880 & PA80206 ends	1
3	80094UZ-06-29-6	6" Signal Wire with (1) .250 & (1) #10 end	1
4	80094UZ-06-29-8	8" Signal Wire with (1) .250 & (1) #10 end	1
5	80094UZ-06-29-5	5" Signal Wire with (1) .250 & (1) #10 end	1
6	80098UZ-06-29-6	6" Blue Signal Wire with (1) .250 & (1) #10 end	1
7	113765-67-67-22.5	BLACK Battery Cable 22.5" - 4ga with (2) 5/16" Ring Terminal Ends	1
8	113766-67-67-12	RED Battery Cable 12" - 4ga with (2) 5/16" Ring Terminal Ends	1
9	113766-67-68-9	RED Battery Cable 9" - 4ga (1) 5/16" and (1) 3/8" Ring Terminal Ends	1
10	113766-67-68-6.5	RED Battery Cable 6.5" - 4ga with (1) 5/16" and (1) 3/8" Ring Terminal Ends	1
11	113766-67-67-9	RED Battery Cable 9" - 4ga with (2) 5/16" Ring Terminal Ends	1
12	113766-67-67-24	RED Battery Cable 24" - 4ga with (2) 5/16" Ring Terminal Ends	1
13	210954-94-06	In Line Fuse Holder with (1) #3/8 and (1) #10 ends	1
14	PA82693	Auto Fuse, ATC Type, Red, 10A	1
	<u>SCALE WIRING OPTION</u>	<u>DESCRIPTION</u>	
15	PA80206	NYLON RING TERM 16-14 GA #10, BLU	4
16	80097UZ-84-06-15	15" Black wire with (1) PA85884 & (1) PA80206 ends	1
17	80095-94-06-20	20" White wire with (1) PA80194 & (1) PA80206 ends	1
18	PA12686-36	36" Length of 14 GA 2 Conductor Auto Duplex Wire	1

REXROTH HYDRAULIC PUMP 51495653 (GEN. 1 / ELE GEN. 4) JULY 2019 TO PRESENT ASSEMBLY

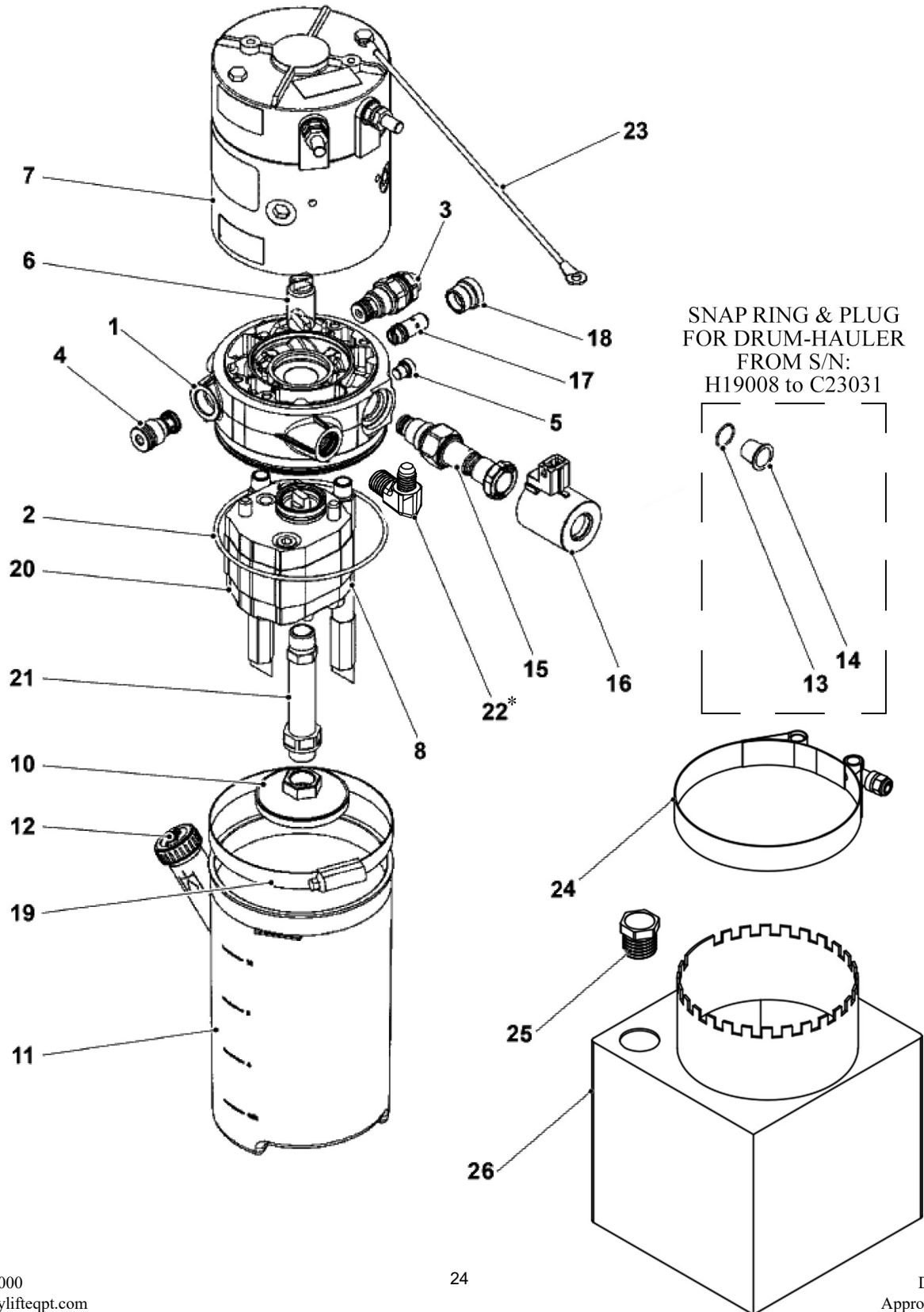

**REXROTH HYDRAULIC PUMP
51495653 (GEN. 1 / ELE GEN. 4) JULY 2019 TO PRESENT
PARTS LIST**

<u>ITEM</u>	<u>PART NO.</u>	<u>DESCRIPTION</u>	<u>QTY</u>
	51495653	Rexroth - Hydraulic Assy. (Gen 1, DH s/n: H19008 to C23031)	
	ELE51495653	Rexroth - Hydraulic Assy. with Elbow (Gen 1, DH s/n: C23051 to Present, EL Gen 4)	
1	51637044	Valve Block	1
2	51048524	Seal Ring	1
3	51347445	Pressure Limiting Valve	1
4	50453256	Check Valve	1
5	51637045	Plug	1
6	51248335	Coupling	1
7	51637048	Pump Motor	1
8	51482662	Piping	2
10	51379966	Oil Filter	1
11	51637055	Hydraulic Tank	1
12	51057393	Breather & Dip Stick	1
13	50426545	Snap Ring	1
14	51637056	Plug	1
15	51637057	Solenoid Valve	1
16	51599237	Magnetic Coil	1
17	51637062	Throttle Valve	1
18	51588730	Plug	1
19	51637064	Clamp	1
20	51637066	Hydraulic Pump	1
21	51637067	Pipe	1
22	* 6-6 C40MXS	90 Male Elbow 3/8 BSPP (for Rexroth Pump)	1
23	** 51637068	Grounding	1
24	5204K16	Rexroth pump metal bolt clamp (4-9/32" to 4-19/32")	1
25	9833K11	1/2" Breather Vent	1
26	# DM106	Rexroth XL Hydraulic Tank	1

* For Drum-Hauler serial # C23051 to present (using ELE51495653)

* For ELDR serial # I23013 to present (using ELE51495653)

* For EL serial # A24024 to present (using ELE51495653, verify on QC)

** Used only on DH800-style Drum-Haulers

First used on A25032

EG1 LIGHT DUTY SINGLE CLAMPING MECHANISM ASSEMBLY

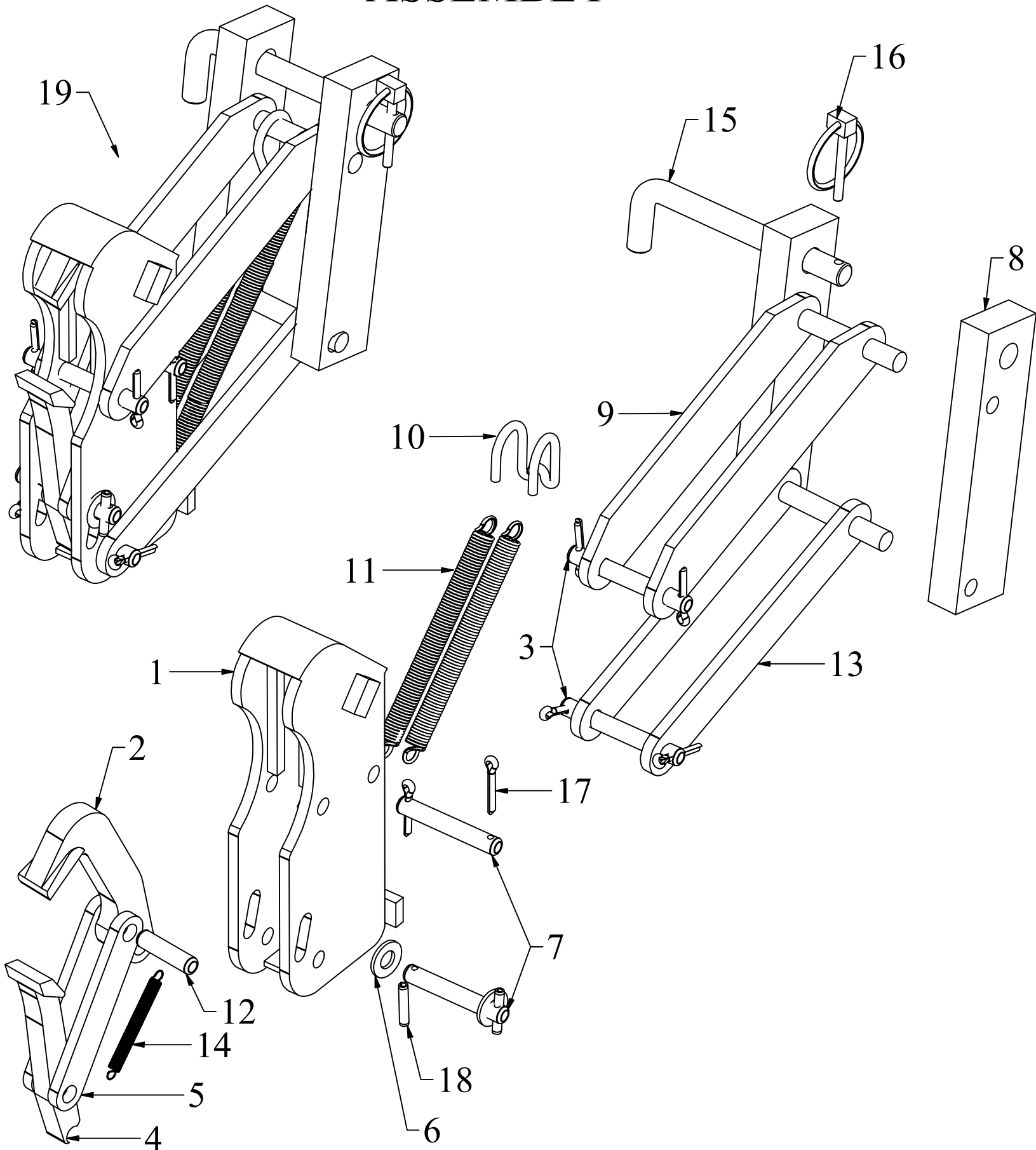

EG1 LIGHT DUTY SINGLE CLAMPING MECHANISM PARTS LIST

<u>ITEM</u>	<u>PART NO.</u>	<u>DESCRIPTION</u>	<u>QTY</u>
1	6302	Housing (Black Powder Coating)	1
1	6302SS	Housing (Stainless Steel)	1
2	9107SS	Stainless Steel Upper Jaw (Spark Resistant)	1
3	15104-1SS	3/8" x 2.242" Pin, Fibre Guard, Housing to Clevis (stainless steel)	2
4	7107SS	Stainless Steel Lower Jaw (Spark Resistant)	1
5	13009-1	Link, Jaw to Jaw (zinc)	2
5	13009-1SS	Link, Jaw to Jaw (stainless steel)	2
6	C616 FW-SS	C616 Flat Washer (stainless steel)	2
7	16104-1SS	3/8" x 1.770" Pin, Upper Jaw Link (stainless steel)	2
8	8002	Adjustment Slide (FDA Black Powder Coating)	2
8	8002SS	Adjustment Slide (Stainless Steel)	2
9	5912	Upper Clevis 8" (FDA Black Powder Coating - 5" Belt Cradle)	1
9	5912SS	Upper Clevis 8" (Stainless Steel - 5" Belt Cradle)	1
9	5912S	Upper Clevis 6" (FDA Black Powder Coating - 3" Belt Cradle)	1
9	5912SS-S	Upper Clevis 6" (Stainless Steel - 3" Belt Cradle)	1
10	8996-2	Clevis Spring Hook (Stainless Steel)	1
11	8206	Clevis Spring (zinc)	2
12	41041SS	3/8" x 1" Pin, Upper Jaw to Link, short (stainless steel)	1
13	6912	Lower Clevis 7 1/2" (FDA Black Powder Coating - 5" Belt Cradle)	1
13	6912SS	Lower Clevis 7 1/2" (Stainless Steel - 5" Belt Cradle)	1
13	6912S	Lower Clevis 5 1/2" (FDA Black Powder Coating - 3" Belt Cradle)	1
13	6912SS-S	Lower Clevis 5 1/2" (Stainless Steel - 3" Belt Cradle)	1
14	1206	Spring, Jaw to Housing (stainless steel)	1
15	10204-1SS	1/2" x 4-1/2" Adjusting Pin (stainless steel)	1
16	HANG-1	3/16 x 1-1/4 Shank Lynch Pin "Hang 1" (9016)	1
16	HANG-1SS	3/16 x 1-1/4 Shank Lynch Pin "Hang 1" Stainless Steel	1
17	3006-CP	Cotter Pin, 1/8" x 3/4" (zinc)	6
17	1/8 x 3/4 CP-SS	1/8 x 3/4 Cotter Pins (stainless steel)	6
18	5/32 x 1/2 Roll Pin	Stainless Steel 5/32 x 1/2 Roll Pin	2
	B-800	White Lithium Grease Can	1
 <u>FULL ASSEMBLIES</u>			
19	9004	EG1 Single Clamping Mechanism (FDA Black Powder Coating - 5" Belt Cradle)	
19	9004S	EG1 Single Clamping Mechanism (FDA Black Powder Coating - 3" Belt Cradle)	
19	9004SRC	EG1 Single Clamping Mechanism (Stainless Steel Housing - Spark Resistant - 5" Belt Cradle)	
19	9004SRC-S	EG1 Single Clamping Mechanism (Stainless Steel Housing - Spark Resistant - 3" Belt Cradle)	
19	9004SS	EG1 Single Clamping Mechanism (FULL Stainless Steel - Spark Resistant - 5" Belt Cradle)	
19	9004SS-S	EG1 Single Clamping Mechanism (FULL Stainless Steel - Spark Resistant - 3" Belt Cradle)	
 <u>PREVENTATIVE MAINTENANCE KITS</u>			
	EG1PMKIT	EG1 Preventative Maintenance Kit	
	EG1BCPMKIT	EG1 Preventative Maintenance Kit w/ Belt Cradle	

**EG1 SINGLE CLAMPING MECHANISM
PREVENTATIVE MAINTENANCE KIT BREAKDOWN**

EG1PMKIT - EG1 PREVENTATIVE MAINTENANCE KIT

<u>ITEM</u>	<u>PART NO.</u>	<u>DESCRIPTION</u>	<u>QTY</u>
11	8206	Clevis Spring (zinc)	2
14	1206	Spring, Jaw to Housing (stainless steel)	1
16	HANG-1	3/16 x 1-1/4 Shank Lynch Pin "Hang 1" (9016)	1
17	3006-CP	Cotter Pin, 1/8" x 3/4" (zinc)	6
18	5/32 x 1/2 Roll Pin	Stainless Steel 5/32 x 1/2 Roll Pin	2
	B-800	White Lithium Grease Can	1

EG1BCPMKIT - EG1 PREVENTATIVE MAINTENANCE WITH BELT CRADLE KIT

<u>PART NO.</u>	<u>DESCRIPTION</u>	<u>QTY</u>
11	8206	Clevis Spring (zinc)
13	5516E	Optional: Belt Cradle Kit (3" wide x 23" long, includes all hardware)
14	1206	Spring, Jaw to Housing (stainless steel)
16	HANG-1	3/16 x 1-1/4 Shank Lynch Pin "Hang 1" (9016)
17	3006-CP	Cotter Pin, 1/8" x 3/4" (zinc)
18	5/32 x 1/2 Roll Pin	Stainless Steel 5/32 x 1/2 Roll Pin
	B-800	White Lithium Grease Can

EG1SRCPMKIT - EG1 PREVENTATIVE MAINTENANCE KIT

<u>ITEM</u>	<u>PART NO.</u>	<u>DESCRIPTION</u>	<u>QTY</u>
11	8206	Clevis Spring (zinc)	2
13	5516E	Optional: Belt Cradle Kit (3" wide x 23" long, includes all hardware)	1
14	1206	Spring, Jaw to Housing (stainless steel)	1
16	HANG-1SS	3/16 x 1-1/4 Shank Lynch Pin "Hang 1" Stainless Steel	1
17	1/8 x 3/4 CP-SS	1/8 x 3/4 Cotter Pins (stainless steel)	6
18	5/32 x 1/2 Roll Pin	Stainless Steel 5/32 x 1/2 Roll Pin	2
	B-800	White Lithium Grease Can	1

THIS PAGE INTENTIONALLY LEFT BLANK

EAGLE-GRIP 1 MAUSER CLAMPING MECHANISM ASSEMBLY

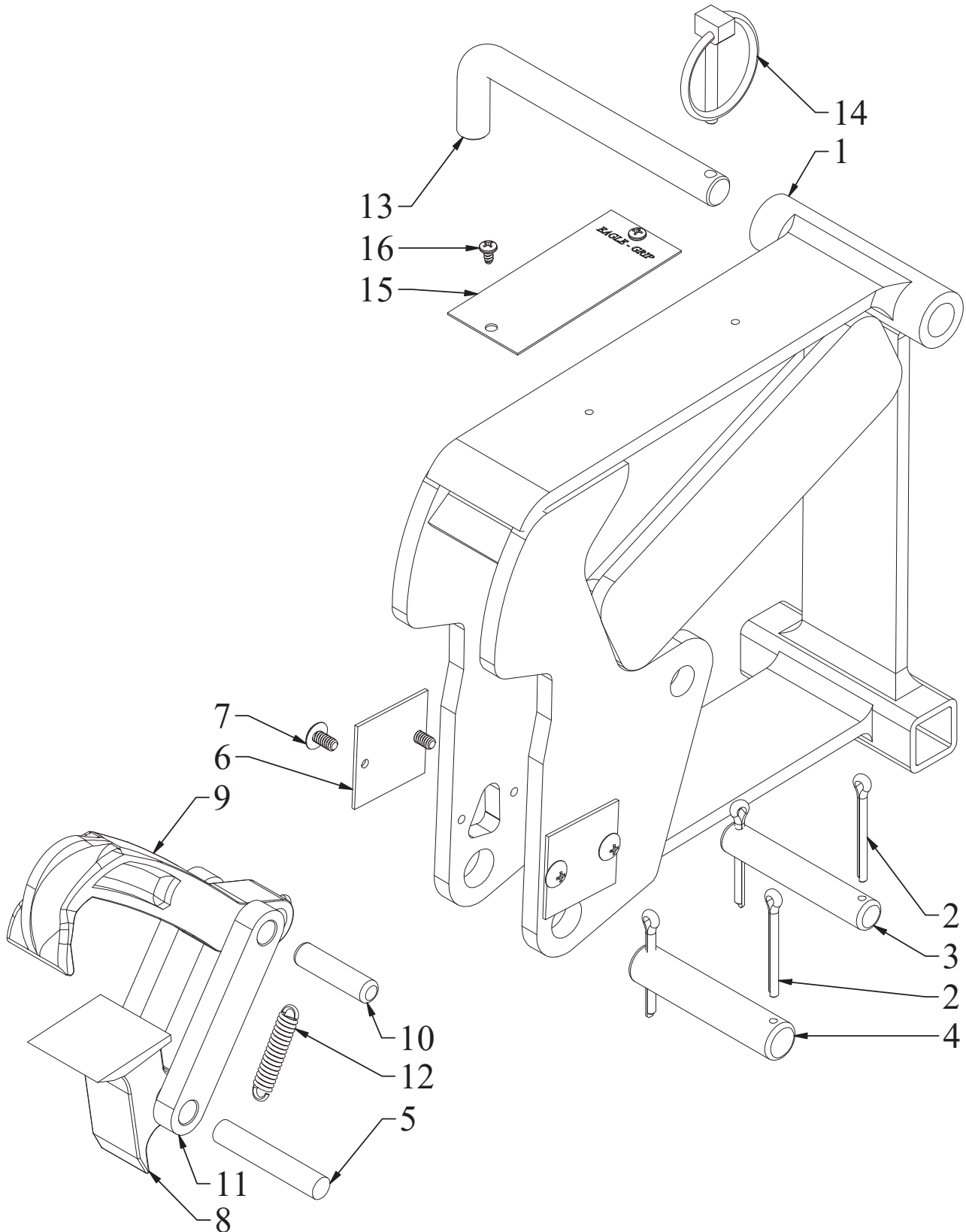

EAGLE-GRIP 1 MAUSER CLAMPING MECHANISM PARTS LIST

<u>ITEM</u>	<u>PART NO.</u>	<u>DESCRIPTION</u>	<u>QTY</u>
1	7902M3	Mauser Housing for 3" Cradle (Black Powder Coating)	1
1	7902M5	Mauser Housing for 5" Cradle (Black Powder Coating)	1
2	6006-CP	Cotter Pin, 5/32" x 1" (zinc)	4
3	16033-1	1/2" x 2.625" Pin, Clevis (zinc)	1
4	3530067	5/8" x 2-7/8" 316 Stainless Steel Pin	1
5	62041	3/8" x 2.13" Pin, Link to Lower Jaw (zinc)	1
6	TSRBS .0625	1 1/2 x 1 1/2 Shim .0625 (1/16")	2
7	10-24 X 3/8 BSC-SS	10-24 x 3/8 Button Socket Cap 18/8 (stainless steel)	4
8	5107M	Mauser Lower Clamp Jaw (Black Powder Coating)	1
9	1007M	Mauser Upper Clamp Jaw (Black Powder Coating)	1
10	72041	3/8" x 1-1/2" Pin, Link to Upper Jaw (zinc)	1
11	70091	Link, Jaw to Jaw	2
12	4306	Jaw Spring (zinc)	1
13	10204-1SS	1/2" x 4-1/2" Adjusting Pin (stainless steel)	1
14	HANG-1	3/16 x 1-1/4 Shank Lynch Pin "Hang 1" (9016)	1
15	MCL044991	PM Tag	1
16	6 x 1/4 RUDS-SS	6 x 1/4 Round Head U Drive Screw (stainless steel)	2
 <u>FULL ASSEMBLIES</u>			
17	9004M3	EG1 Mauser Clamping Mechanism for 3" Cradle (Black Powder Coating)	
17	9004M5	EG1 Mauser Clamping Mechanism for 5" Cradle (Black Powder Coating)	

EG2 LIGHT DUTY DOUBLE CLAMPING MECHANISM ASSEMBLY

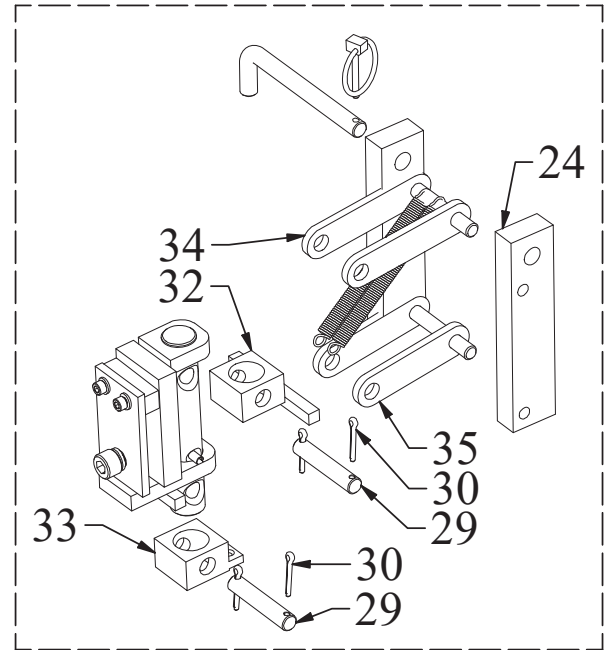
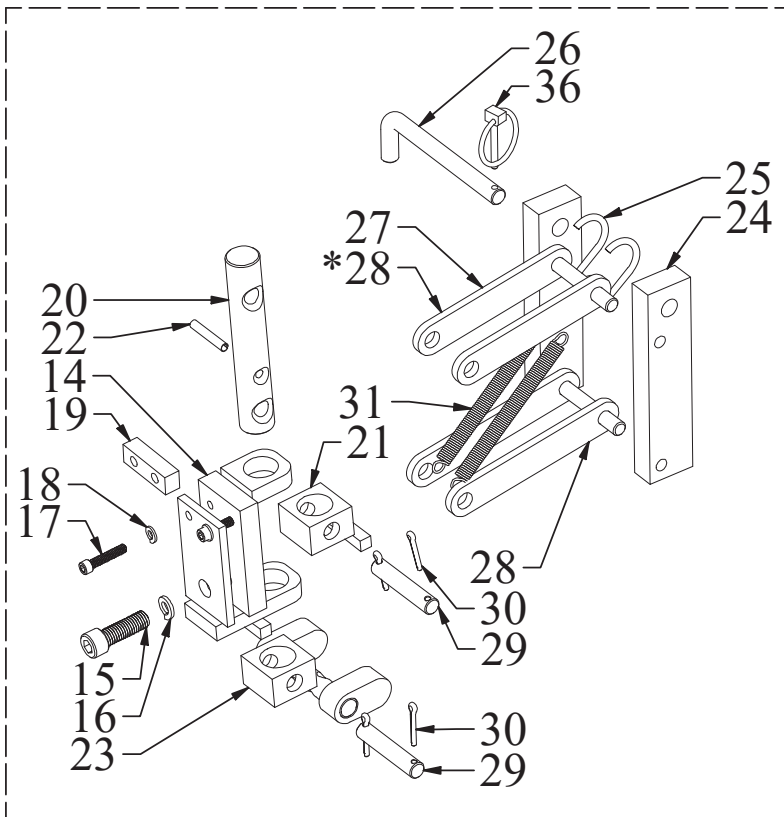

SEEN ON LEFT: **ERGO UNITS WITH A 5" BELT CRADLE** WILL PRIMARILY USE A 6" UPPER CLEVIS (#27) AND A 5-1/2" LOWER CLEVIS (#28). ALONG WITH A LOWER PIVOT BLOCK WITH OVAL STOP BARS (#23) AND AN UPPER PIVOT BLOCK WITH A 2-1/4" STOP BAR (#21).

***EAGLE-GRIP ATTACHMENTS** WILL PRIMARILY USE 5-1/2" LOWER CLEVISES (#28) FOR BOTH THE TOP AND BOTTOM CLEVISES.

SEEN ON THE RIGHT: **ERGO UNITS WITH A 3" BELT CRADLE** WILL PRIMARILY USE A 4-1/2" UPPER CLEVIS (#34) AND A 4" LOWER CLEVIS (#35). ALONG WITH A LOWER PIVOT BLOCK (#33) AND AN UPPER PIVOT BLOCK WITH A 3-3/4" STOP BAR (#32).

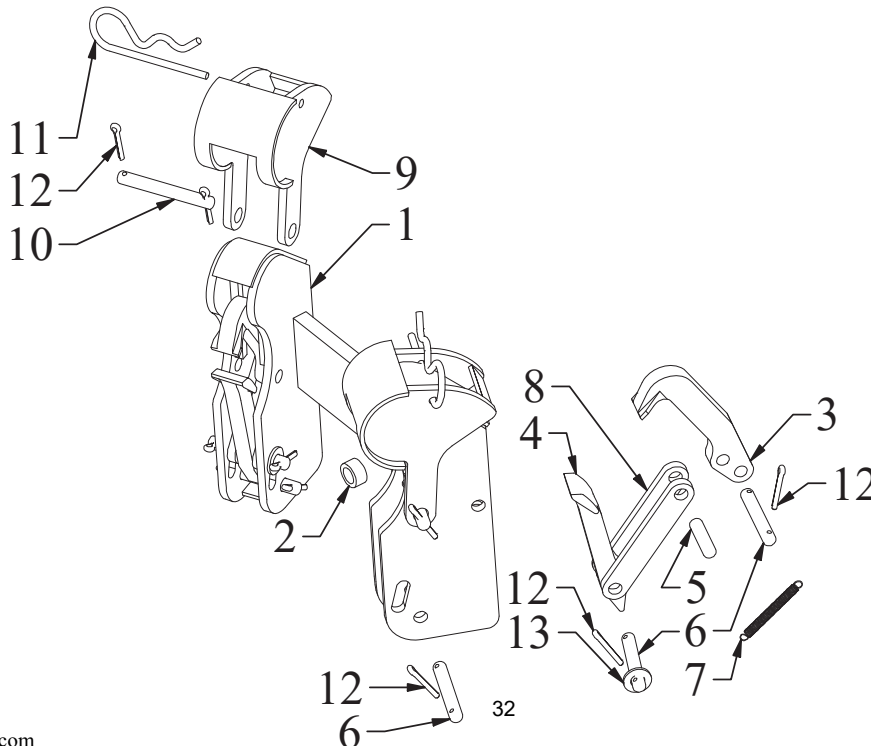

**EG2 LIGHT DUTY DOUBLE CLAMPING MECHANISM
PARTS LIST**

<u>ITEM</u>	<u>PART NO.</u>	<u>DESCRIPTION</u>	<u>QTY</u>
1	7302R	Housing, Double Clamping Mechanism (Black Powder Coating)	1
1	7302RSS	Housing, Double Clamping Mechanism (Stainless Steel)	1
2	10001	Bushing, Housing Yolk Trunion (zinc)	1
3	9107SS	Stainless Steel Upper Jaw (Spark Resistant)	2
4	7107SS	Stainless Steel Lower Jaw (Spark Resistant)	2
5	41041SS	3/8" x 1" Pin, Upper Jaw to Link, short (stainless steel)	2
6	16104-1SS	3/8" x 1.770" Pin, Upper Jaw Link (stainless steel)	6
7	1206	Spring, Jaw to Housing (stainless steel)	2
8	13009-1	Link, Jaw to Jaw (zinc)	4
8	13009-1SS	Link, Jaw to Jaw (stainless steel)	4
9	621	Fiber Drum Guard (Black Powder Coating)	2
9	621SS	Fiber Drum Guard (Stainless Steel)	2
10	15104-1SS	3/8" x 2.242" Pin, Fibre Guard, Housing to Clevis (stainless steel)	2
11	7019	3-7/8" Hair Pin Clip (zinc)	2
11	92391A210	18-8 Stainless Steel Cotter Pin, 18-8, Fits 7/8"-1", 3-3/4"	2
12	3006-CP	Cotter Pin, 1/8" x 3/4" (zinc)	16
12	1/8 x 3/4 CP-SS	1/8 x 3/4 Cotter Pins (stainless steel)	16
13	C616 FW-SS	C616 Flat Washer (stainless steel)	4
14	6012R	Universal Body (Black Powder Coating)	1
15	1/2-13 x 1 1/2 SHCS	1/2-13 x 1 1/2 Socket Head Cap Screw (zinc)	1
15	1/2-13 x 1 1/2 SHCS-SS	1/2-13 x 1 1/2 Socket Head Cap Screw (Stainless Steel)	1
16	1/2 LW	1/2 Lock Washer (zinc)	1
16	1/2 LW-SS	1/2 Lock Washer (stainless steel)	1
17	1/4-20 x 1 1/4 SHCS	1/4-20 x 1 1/4 Socket Head Cap Screw Alloy Plated	2
17	1/4-20 x 1 1/4 SHCS-SS	1/4-20 x 1 1/4 Socket Head Cap Screw (stainless steel)	2
18	1/4 LW	1/4 Lock Washer (zinc)	2
18	1/4 LW-SS	1/4 Lock Washer (stainless steel)	2
19	50064	Spacer (Black Powder Coating)	1
20	64061	Universal Pin (zinc)	1
20	64061-SS	Universal Pin (Stainless Steel)	1
21	50021R	Upper Pivot Block (Black Powder Coating - 5" Belt Cradle)	1
22	70062	Spring Roll Pins 1/4 X1-1/2 (zinc) (xref 70641)	1
22	1/4 x 1-1/2 SP-SS	1/4" x 1-1/2" Stainless Steel Spring Roll Pin	1
23	5012R	Lower Pivot Block with Oval Stop Bars (Black Powder Coating - 5" Belt Cradle)	1
24	8002	Adjustment Slide (FDA Black Powder Coating)	2
25	8996-2	Clevis Spring Hook (Stainless Steel)	1
26	10204-1SS	1/2" x 4-1/2" Adjusting Pin (stainless steel)	1
27	5912R	Upper Clevis 6" (Black Powder Coating - 5" Belt Cradle)	1
27	5912RZ	Upper Clevis 6" (FDA Powder Coating - 5" Belt Cradle)	1
28	6912R	Lower Clevis 5 1/2" (Black Powder Coating - 5" Belt Cradle)	1
28	6912RZ	Lower Clevis 5 1/2" (FDA Powder Coating - 5" Belt Cradle)	1
29	16033-1	1/2" x 2.625" Pin, Clevis (zinc)	2
29	EL.5-3SSH	1/2" x 3" Stainless Steel Pin - with cotter pin holes	2
30	6006-CP	Cotter Pin, 5/32" x 1" (zinc)	4
30	5/32 x 1 CP-SS	5/32 x 1 Cotter Pins (Stainless Steel)	4
31	8206	Clevis Spring (zinc)	2
32	50021RS	Upper Pivot Block (Black Powder Coating - 3" Belt Cradle)	1
33	5012RS	Lower Pivot Block (Black Powder Coat- 3" Belt Cradle)	1
34	5912RS	Upper Clevis 4 7/16" (Black Powder Coating - 3" Belt Cradle)	1
34	5912RZS	Upper Clevis 4 7/16" (FDA Powder Coating - 3" Belt Cradle)	1
35	6912RS	Lower Clevis 4" (Black Powder Coating - 3" Belt Cradle)	1
35	6912RZS	Lower Clevis 4" (FDA Powder Coating - 3" Belt Cradle)	1
36	HANG-1	3/16 x 1-1/4 Shank Lynch Pin "Hang 1" (9016)	1
36	HANG-1SS	3/16 x 1-1/4 Shank Lynch Pin "Hang 1" Stainless Steel	1

FULL ASSEMBLIES

4004R	EG2L Double Clamping Mechanism (Black Powder Coating - 5" Belt Cradle)
4004RS	EG2L Double Clamping Mechanism (Black Powder Coating - 3" Belt Cradle)
4004RSRC	EG2L Double Clamping Mechanism (Stainless Steel Housing - Spark Resistant - 5" Belt Cradle)
4004RSRC-S	EG2L Double Clamping Mechanism (Stainless Steel Housing - Spark Resistant - 3" Belt Cradle)
4004SS	EG2L Double Clamping Mechanism (FULL Stainless Steel - Spark Resistant - 5" Belt Cradle)
4004SS-S	EG2L Double Clamping Mechanism (FULL Stainless Steel - Spark Resistant - 3" Belt Cradle)

PREVENTATIVE MAINTENANCE KITS

EG2LPMKIT	EG2LDCM Preventative Maintenance Kit
EG2LSRCPMKIT	EG2LDCMSRC Preventative Maintenance Kit

**EG2 LIGHT DUTY DOUBLE CLAMPING MECHANISM
PREVENTIVE MAINTENANCE KIT PARTS LIST**

EG2LPMKIT - EG2L PREVENTATIVE MAINTENANCE KIT

<u>ITEM</u>	<u>PART NO.</u>	<u>DESCRIPTION</u>	<u>QTY</u>
7	1206	Spring, Jaw to Housing (stainless steel)	2
11	7019	3-7/8" Hair Pin Clip (zinc)	2
12	3006-CP	Cotter Pin, 1/8" x 3/4" (zinc)	16
31	8206	Clevis Spring (zinc)	2
36	HANG-1	3/16 x 1-1/4 Shank Lynch Pin "Hang 1" (9016)	1
-	5516E	Optional: Belt Cradle Kit (3" wide x 23" long, includes all hardware)	1
-	B-800	White Lithium Grease Can	1

EG2LSRCPMKIT - EG2LSRC PREVENTATIVE MAINTENANCE KIT

	<u>PART NO.</u>	<u>DESCRIPTION</u>	<u>QTY</u>
7	1206	Spring, Jaw to Housing (stainless steel)	2
11	92391A210	18-8 Stainless Steel Cotter Pin, 18-8, Fits 7/8"-1", 3-3/4"	2
12	1/8 x 3/4 CP-SS	1/8 x 3/4 Cotter Pins (stainless steel)	16
31	8206	Clevis Spring (zinc)	2
36	HANG-1SS	3/16 x 1-1/4 Shank Lynch Pin "Hang 1" Stainless Steel	1
-	5516E	Optional: Belt Cradle Kit (3" wide x 23" long, includes all hardware)	1
-	B-800	White Lithium Grease Can	1

THIS PAGE INTENTIONALLY LEFT BLANK

SCALE HARDWARE & WIRING FOR ERGO & EAGLE-GRIP STYLE MASTS ASSEMBLY

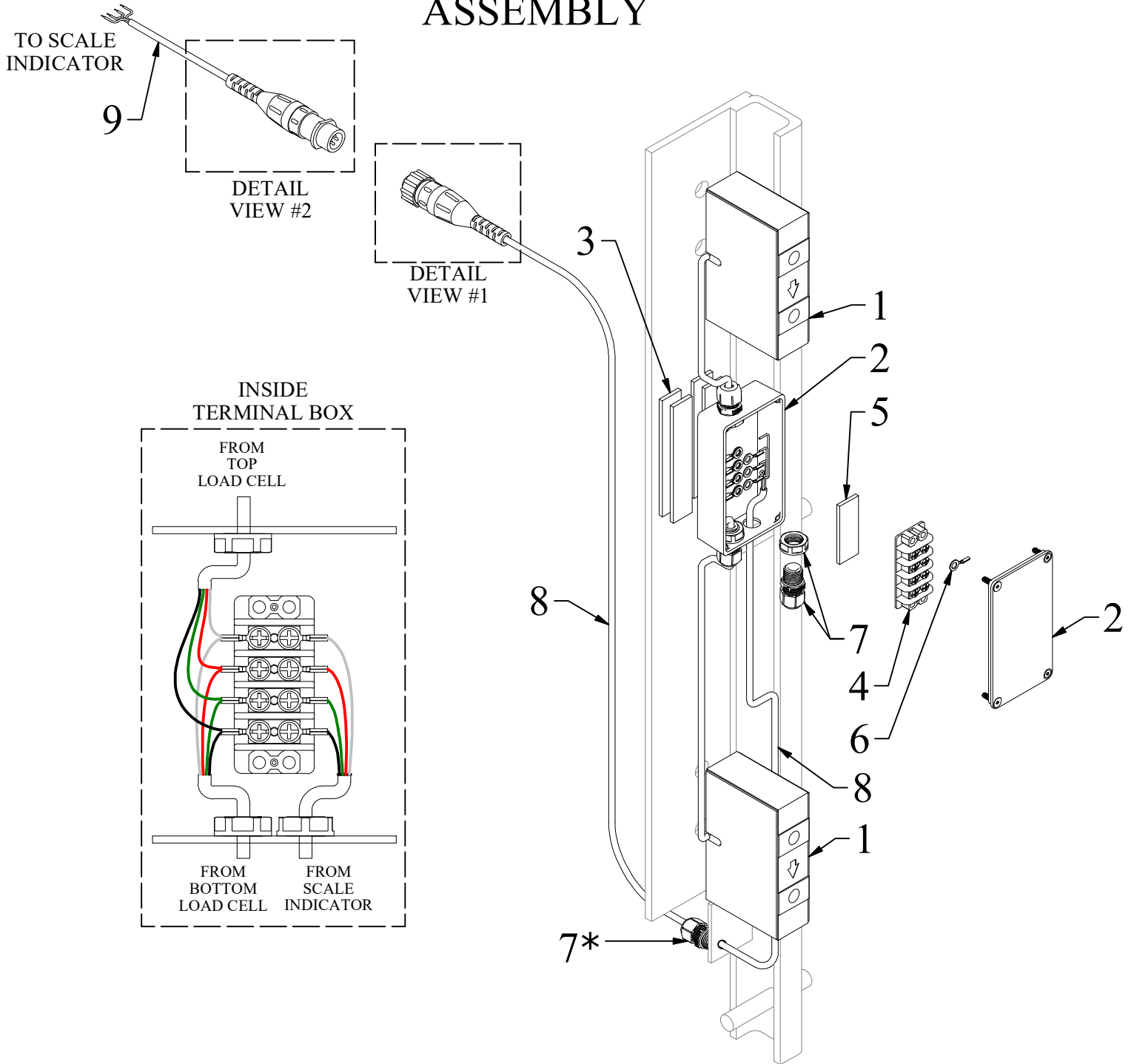

DETAIL VIEW #1 (MACHINE SIDE)

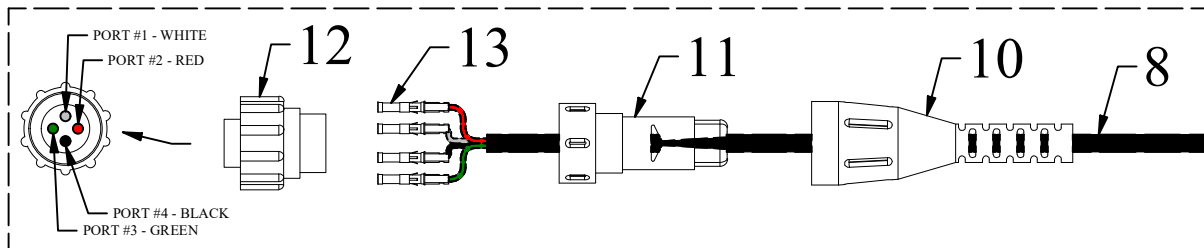

DETAIL VIEW #2 (SCALE SIDE)

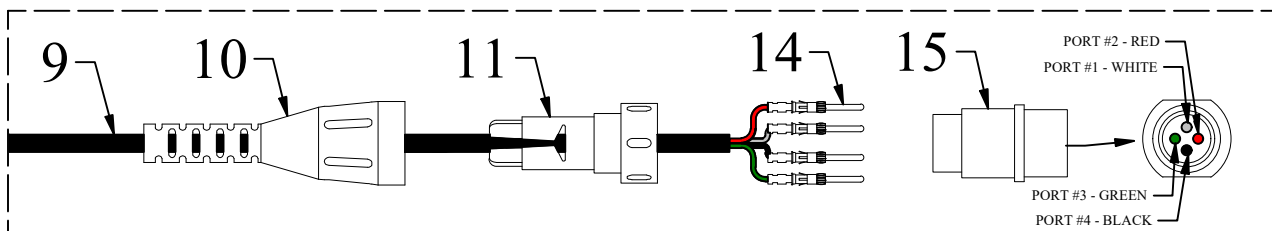

**SCALE HARDWARE & WIRING
FOR ERGO AND EAGLE-GRIP MASTS
PARTS LIST**

ITEM	PART NO.	DESCRIPTION	QTY
1	HM1000	Load Cell with 4' cable	2
2	CU-124	Terminal Box Enclosure	1
3	75315A34-4	Foam Tape, 2 sided adhesive, 3/4" X .125" x 4" length	4
4	7527K64	Terminal Block (Strip) 7/16", 4 circuits	1
5	75315A34-2	Foam Tape, 2 sided adhesive, 3/4" X .125" x 2" length	1
6	3A214	Terminal Eyelet	12
7	ZZHEY3208	Cable Fitting	4
8	3530359	Ergo Scale Cable Assembly (Female End) - 60" Length	1
8	3530360	Eagle-Grip Scale Cable Assembly (Female End) - 30" Length	1
9	3530361	Eagle-Grip/Ergo Scale Cable Assembly (Male End) - 24" Length	1
10	AP2074891	Strain Relief	2
11	AP2074901	Cable Grip	2
12	AP2060601	Connector Plug Size 11-4 (Female)	1
13	AP661054	Terminal Socket	4
14	AP661034	Terminal Pin	4
15	AP2061531	Connector Recp CPC 11-4 (Male)	1

* Modified Strain Relief

Non-Intrinsically Safe Indicators

7000XLM	Doran® 7000XL Non-intrinsically Safe Scale Indicator
SUB0853	Rechargeable Battery, with wire and terminals (2200, 7000, 8000)
2200	Doran® 2200 Non-intrinsically Safe Scale Indicator (Numeric Keypad)
EXOPT319	Battery Option for Non-Intrinsically Safe 2200 Indicator
164582	Rice Lake®482 Indicator w Internal Battery & Charger
164585	Rice Lake®482 Plus Indicator w Internal Battery & Charger
107708	Rice Lake®720i Indicator

Intrinsically Safe Indicators

185288	Rice Lake®882IS Indicator w Battery Pack & Safe Area Charger
185291	Rice Lake®882IS PLUS Indicator w Battery Pack & Safe Area Charger
180831	Rice Lake®882IS Battery
194191	Rice Lake®882IS Battery Charger (IS6V2, 100-240 VAC)
72210052	Mettler Toledo IND226x Indicator ONLY
72258718	Mettler Toledo IND560x Indicator ONLY
64060627	Mettler Toledo EX Indicator Battery (Includes Cable)
64060217	Mettler Toledo Battery Charger (Safe Area, US Plug)

EAGLE-GRIP, EL & MFCR SCALE BRACKET ASSEMBLY

EL & MFCR SWIVEL BRACKET

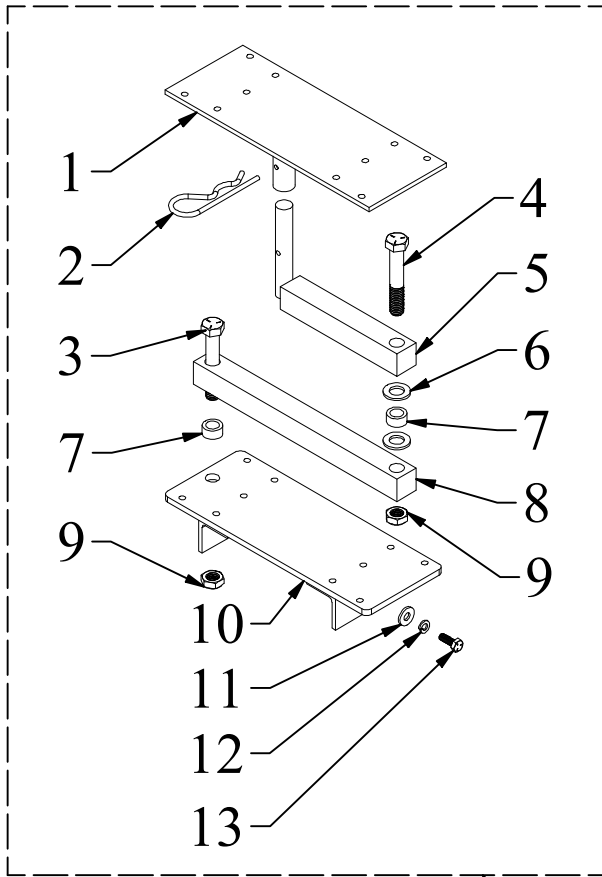

EL ELEVATED RISER

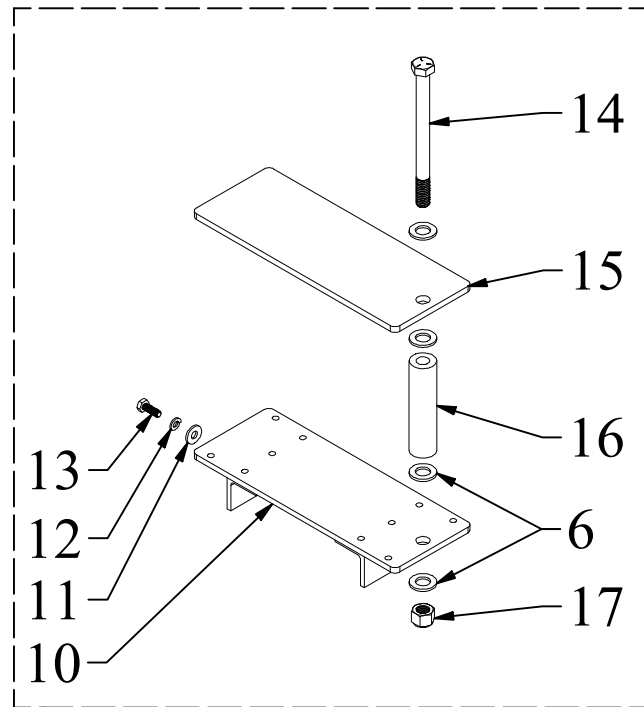

EAGLE-GRIP SWIVEL BRACKET

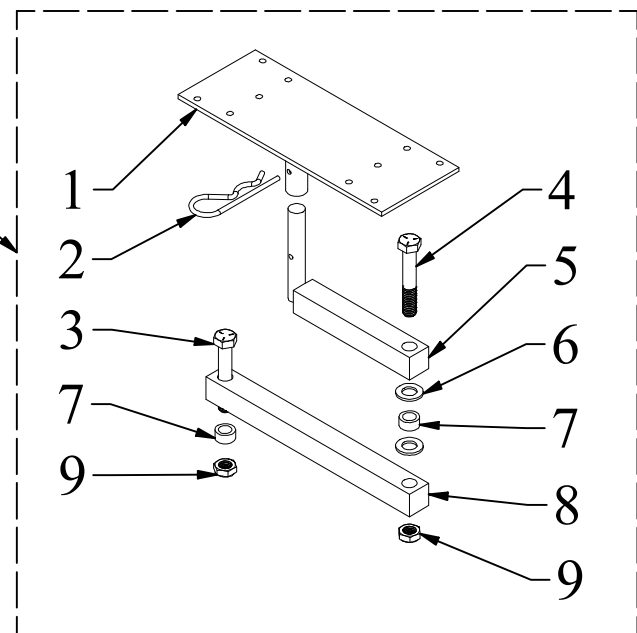

18

19

20

**EAGLE-GRIP, EL & MFCR
SCALE BRACKET
PARTS LIST**

<u>ITEM</u>	<u>PART NO.</u>	<u>DESCRIPTION</u>	<u>QTY</u>
1	3530348	Indicator Mount Bracket With Tube	1
2	98335A094	Zinc-plated steel cotter pin, 7/8"-1 D, 3-3/4 L	2
3	1/2-13 x 2 1/2 HHCS	1/2-13 x 2 1/2 Hex Head Cap Screw Grade 5 (zinc)	2
4	1/2-13 x 3 HHCS	1/2-13 x 3 Hex Head Cap Screw Grade 5 (zinc)	2
5	2580309	Scale Swing Bracket Post Bracket	2
6	1/2 FW	1/2 Flat Washer (zinc)	8
7	10001	Bushing, Housing Yolk Trunion (zinc)	4
8	2580308	Scale Swing Bracket Mid Bracket	2
9	1/2-13 THIN NLN	1/2-13 Nylon Locking Nut (THIN ZINC)	4
10	2580306	Ergo Scale Mount - 1.5" High	2
10	3530396	Ergo Scale Mount - 6.5" High	2
11	1/4 FW SAE	1/4 Flat Washer SAE (zinc)	4
12	1/4 LW	1/4 Lock Washer (zinc)	4
13	1/4-20 x 3/4 HHCS	1/4-20 x 3/4 Hex Head Cap Screw Grade 5 (zinc)	4
14	1/2-13 x 6 HHCS	1/2-13 x 6 Hex Head Cap Screw Grade 5 (zinc)	1
15	3530445	Elevated Scale Plate	1
16	3530446	Elevated Scale Plate Spacer	1
17	1/2-13 NLN	1/2-13 Nylon Locking Nut (zinc)	1
<u>FULL ASSEMBLY</u>			
18	3530447	Ergo Elevated Scale Plate Assembly	1
19	3530404	Ergo Scale Swing Out Bracket 1.5" Assembly	1
19	3530405	Ergo Scale Swing Out Bracket 6.5" Assembly	1
20	3530469	Eagle-Grip Scale Swing Out Bracket Assembly	1

DCM0035L

Technical Specifications

Nominal Voltage	12V
Nominal Capacity	35Ah (20 Hr Rate to 1.75V/cell)
Chemistry	Lead Acid -AGM

Physical Specifications

Length	195mm	7.68in
Width	130mm	5.12in
Height	164mm	6.46in
Height w/Terminal	180mm	7.09in
Weight (+/- 5%)	10.4Kg	22.9lbs
Terminal Type	INSERT TERMINALS	
Case Material	ABS	

Charging Specifications

Charge Voltage	Battery	Per Cell
Float	13.5V~13.8V	2.25V~2.30V
Cycle	14.4V~15.0V	2.40V~2.50V
Max. Charge Current	9.9A	

Capacity Specifications

5 Second Discharge Current	495A	
Self Discharge (to 80% capacity)	3 Months	91%
	6 Months	82%
	12 Months	64%
Internal Resistance	11mΩ(25°C)	

Temperature Specifications

Operating Temperature Capability **-40° F (-40° C) to 140° F (60° C)**

Recommended parameters for optimal battery life and performance:

Charging: 32° F to 104° F (0° C to 50° C), Discharging: 5° F to 122° F (-15° to 50° C),

Storage: 50° to 77° F (10° C to 25° C)



FEATURES:

- Long life for deep discharge uses
- Ideal for applications using major capacity prior to recharging
- Depth of discharge should be between 50% & 80% and recharged as soon as possible
- Flexibility of mounting orientation
- VRLA technology to eliminate spills and over-pressurization
- Maintenance-free

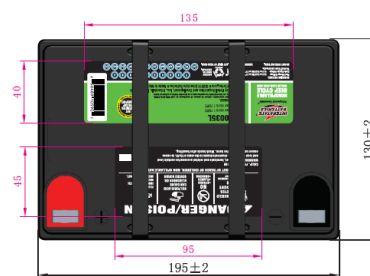

FOR REFERENCE ONLY
HANDLE TRUE TO PHOTO ABOVE

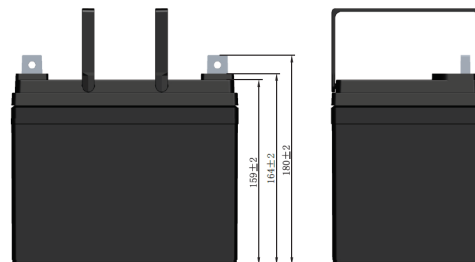

Storage Characteristics

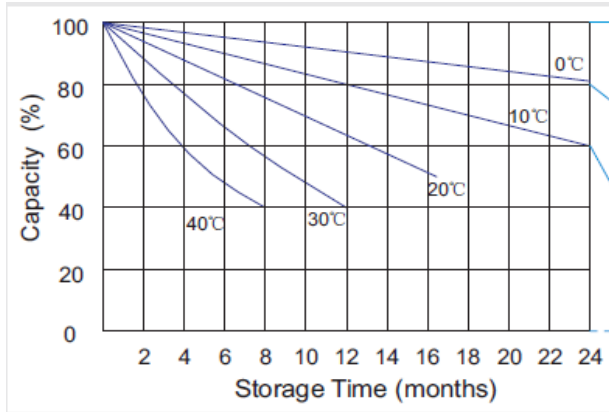

Cycle Life of Deep Cycle

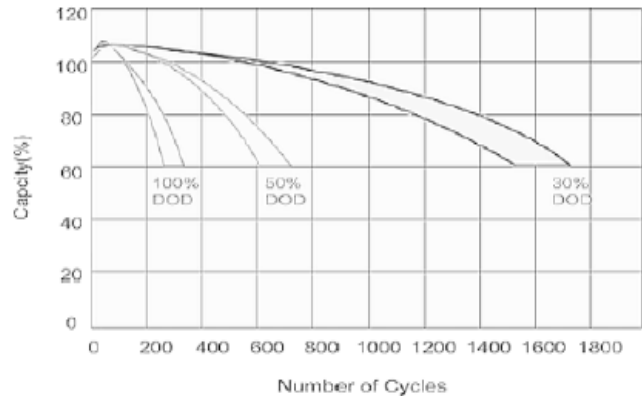

Constant Current Discharge Characteristics: A (25°C)

F.V/Time	5 min	30 min	1 hr	3 hr	5 hr	10 hr	20 hr
1.85V/cell	42.00	26.00	16.50	7.63	5.26	3.12	1.75
1.80V/cell	51.70	28.90	18.50	8.28	5.64	3.30	1.77
1.75V/cell	60.00	31.20	19.30	8.60	5.83	3.33	1.79
1.70V/cell	64.70	32.70	19.09.00	8.83	5.93	3.37	1.82
1.67V/cell	69.90	34.00	20.60	9.08	6.10	3.44	1.84
1.60V/cell	75.60	35.60	21.30	9.27	6.24	3.47	1.85

Constant Power Discharge Characteristics: W (25°C)

F.V/Time	5 min	30 min	1 hr	3 hr	5 hr	10 hr	20 hr
1.85V/cell	78.30	50.00	32.00	14.90	10.30	6.17	3.51
1.80V/cell	95.10	54.90	35.60	16.10	11.00	6.53	3.53
1.75V/cell	109.10	59.00	37.10	16.70	11.40	6.59	3.56
1.70V/cell	116.10	61.60	38.20	17.10	11.60	6.65	3.63
1.67V/cell	124.40	63.70	39.30	17.50	11.90	6.78	3.67
1.60V/cell	132.40	66.10	40.40	17.80	12.10	6.85	3.68



PRO Charging Systems

Installation and Operating Instructions (for chargers shown below)

Industrial SERIES



IS1- One 6 amp output



IS2- Two 6 amp outputs



IS3- Three 6 amp outputs

*For additional information please call our
Technical Support Group 800.742.2740*



081512

PRO CHARGING SYSTEMS, LLC
1551 Heil Quaker Boulevard, LaVergne, TN 37086-3539

**INSTALLATION AND OPERATING INSTRUCTIONS
FOR THE FOLLOWING BATTERY CHARGING SYSTEMS:**

Model #	Description	Total Output	Independently charge 12V batteries in the following systems:
Recreation Series			
IS1	One 6 Amp Bank	6 Amps	12V
IS2	Two 6 Amp Banks	12 Amps	12V, 24V
IS3	Three 6 Amp Banks	18 Amps	12V, 24V or 36V

IMPORTANT NOTICE

Please save and read all safety, operating and installation instructions before installing or applying AC power to your PCS on-board battery charging system. Please contact PCS with any product, installation, or service questions at technical support (800.742.2740).

INTRODUCTION

Pro Charging Systems (PCS) has been manufacturing waterproof, on-board battery charging systems since 1989. Our charging systems are designed and built tough to withstand intense vibration, extreme temperature variations and submersion without damaging the unit. Our systems use temperature compensation in order to fully charge a battery in hot or cold environments and are controlled by microprocessors in order to assure precise control over each totally independent charging bank. All of our chargers have true reverse polarity protection and incorporated a float maintenance mode upon completion of each charge cycle.

TABLE OF CONTENTS	
Important Safety Instructions.....	Pages 2-3
Product Summary.....	Pages 4-5
Installation Instructions.....	Pages 5-6
Trouble Shooting.....	Page 7
Warranty Information.....	Page 8

IMPORTANT SAFETY INSTRUCTIONS

Use of attachments not recommended or sold by PCS may result in a risk of fire, electrical shock, or injury to persons.

To reduce risk of damage to the electrical plug and power cord, always pull by the plug rather than by the power cord when disconnecting charger.

When using an extension cord, make sure:

1. That pins on the extension cord plug are the same number, size and shape as those of the charger's plug;
2. That extension cord meets UL (Underwriters Laboratories, Inc.) acceptance and is in proper operating condition;
3. That wire size is large enough for the ac ampere rating of charger.

Do not operate charger with a damaged cord or plug—replace the cord or plug immediately.

Do not operate charger if it has received a sharp blow, been dropped or otherwise damaged in any way; contact our technical support group for assistance (800.742.2740).

Do not disassemble charger; contact technical support when service or repair is required. Incorrect reassembly may result in risk of electrical shock or fire.

To reduce risk of electrical shock, unplug charger from outlet before attempting any maintenance or cleaning.

WARNING: RISK OF EXPLOSIVE GASES

1. **WORKING IN THE VICINITY OF A LEAD-ACID BATTERY IS DANGEROUS.** Batteries generate explosive gases during normal battery operation. For this reason, it is of utmost importance that each time before using your charger, you read this manual and follow the instructions exactly.
2. To reduce risk of battery explosion, follow these instructions and those published by the battery manufacturer and by the manufacturer of any equipment you intend to use in the vicinity of battery. Review all cautionary markings on any product being utilized in or around the charging device.

PERSONAL PRECAUTIONS

Someone should be within range of your voice or close enough to come to your aid when you work near a lead-acid battery.

Have plenty of fresh water and soap nearby in case battery acid contacts skin, clothing, eyes, or other surfaces.

Wear complete eye protection and clothing protection. Avoid touching eyes while working near battery.

If battery acid contacts skin or clothing, wash immediately with soap and water. If acid enters eye, immediately flood eye with running cold water for at least 10 minutes and seek medical attention.

NEVER smoke or allow a spark or flame in the vicinity of a battery or engine.

Be extra cautious to reduce risk of dropping a metal tool onto battery. This might cause a spark or short-circuit a battery, possibly resulting in an explosion.

Remove personal metal items such as rings, bracelets, necklaces, and watches when working with a lead-acid battery. A lead-acid battery can produce a short-circuit current high enough to weld a ring, or the like, to metal, causing a severe burn.

Use charger for charging a LEAD-ACID (lead acid, sealed lead acid, gel cell, and AGM) battery only. It is not intended to supply power to a low voltage electrical system other than in a starter-motor application. Do not use battery charger for charging dry-cell batteries that are commonly used with home appliances. These dry cell batteries may explode, causing personal injury and damage to property.

NEVER charge a frozen battery.

PREPARING TO CHARGE

If it is necessary to remove the battery or batteries to charge, always remove grounded terminal from battery first. Make sure all accessories are off, so as not to cause battery arcing.

Be sure the area around any battery is well ventilated while batteries are being charged. On occasion, “gas fumes” may be present during charging and can be forcefully blown away by using a piece of cardboard or other nonmetallic material as a fan. Proper ventilation is always recommended in the charging area.

Clean all of the battery terminals. Be careful to keep corrosion from coming into contact with eyes.

Add distilled water in each cell (wet cell batteries) until battery acid reaches level specified by battery manufacturer. This helps purge excessive gas from cells. Do not overfill. For a battery without cell caps, carefully follow manufacturer’s recharging instructions.

Study all battery manufacturers’ specific precautions such as removing or not removing cell caps while charging and recommended rates of charge.

Extension cords should be industrial grade/heavy duty UL approved and grounded. Check extension cord before use for damage, bent prongs and cuts. Replace if damaged.

Always make your extension cord connection on the charger side first. After connecting the extension cord to the charger, proceed to plug the extension cord into a 120VAC GFCI protected (Ground Fault Circuit Interrupt) A/C outlet. The unit will operate with a VAC input range of 90VAC-264VAC.

Always remove the extension cord from the A/C outlet first when charging is completed followed by unplugging the charger.

PRODUCT SUMMARY

General Operation:

Use the following guidelines in this manual to install your fully automatic PCS battery charging system.

Assure that the area around your charger and batteries is properly ventilated. Connect your extension cord with no A/C power present to the battery charger and proceed to plug your extension cord in at a nearby A/C outlet.

Once you plug in your PCS battery charging system, your batteries will be simultaneously and independently charged to 100%. Unlike systems that utilize one large charger to attempt to charge multiple batteries, your system utilizes a totally independent battery charger for each battery. Each charging bank will remain in a “float” stage once the battery is charged and then monitor and/or maintain the battery indefinitely.

We recommend that you leave your system plugged in. This will reduce sulfation on the lead plates of the batteries and allow your PCS charging system to keep your batteries fully maintained and ready to perform at their best.

Independent Charging Bank Indications

When your battery charging system is activated, each bank provides charging information utilizing 1 red Light Emitting Diode (LED) indicator and one green Light Emitting Diode (LED) indicator. The Red (CHARGING) LED indicates d/c current is flowing to the battery and the Green (READY) LED indicates that the charger has finished it’s bulk and absorption stage and has entered the float maintenance mode. There is also a Green (POWER) LED that illuminates to indicate that power is supplied to the charger when it is plugged in properly to a functioning A/C outlet.

Below is an example of the display on a Three output Industrial Series Charger (IS3):

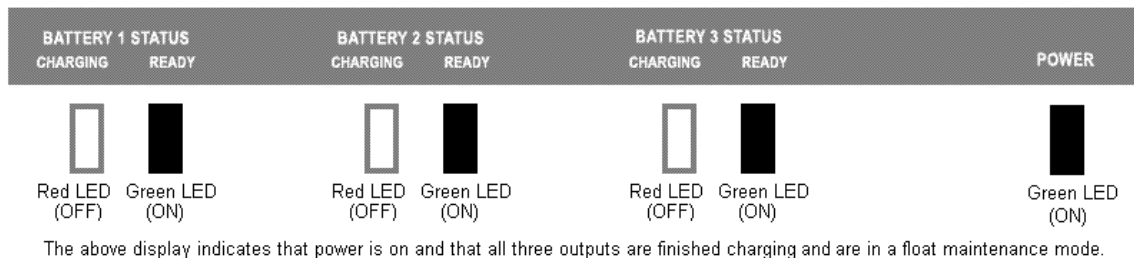
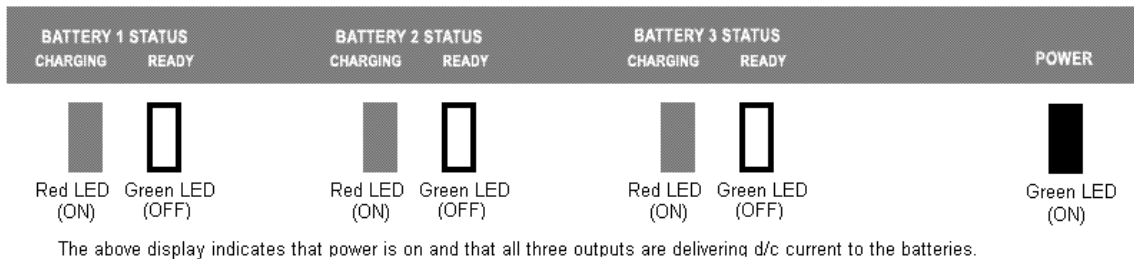
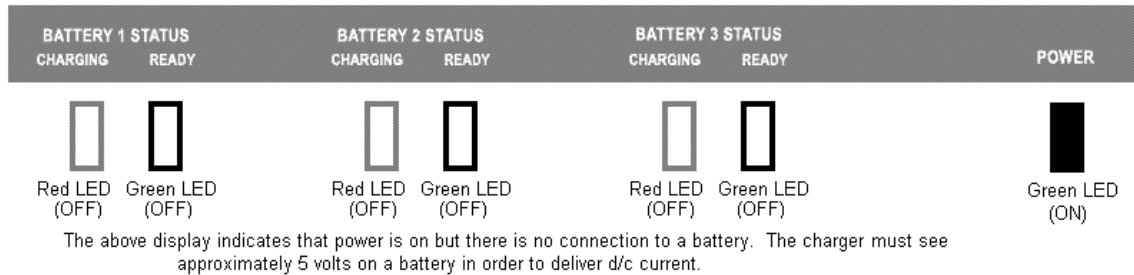

INSTALLATION INSTRUCTIONS

All PCS battery charging systems are designed to be permanently installed in a well-ventilated area and have no mounting restrictions.

Do not make any electrical connections to the power supply (AC) or to a battery (DC) until the installation process has been completed.

If mounting the charger in a boat, please choose a flat surface as high above the water level as possible. If a compartment wall is chosen, make certain its strength is adequate to support the weight of the charger.

Use the mounting flanges of the charger to mark locations for starter holes. Drill a 1/16 inch hole at each marked location. Then, utilize all stainless steel screws that have been provided and install the charger securely, being cautious not to over tighten the screws. Silicon sealer should be used to secure and waterproof the screw holes.

IMPORTANT NOTICE

The mounting brackets of the system may contain keyholes that are designed so that screws can be started before putting the charger into place. If applicable, the keyhole locations vary depending on which model you own.

Before making any connections, prepare batteries as follows:

- (a) With caps securely in place, thoroughly clean the case and posts with a solution of baking soda and water. Be careful not to allow any baking soda to get inside the case.

- (b) All posts, terminals, and connectors should be cleaned to a shiny bright finish, using a wire brush or sand paper. This should be done periodically to assure maximum conductivity between the battery and the charger.

Each charge cable assembly is equipped with a temperature sensor located at the junction of each set of ring terminals. Attempts to shorten the cables could partially disable the charger. Therefore, we recommend that you do not make any adjustments without first consulting our technical support group (800.742.2740). Proper cable extensions may be purchased in 5', 10', and 15' lengths. See picture below.

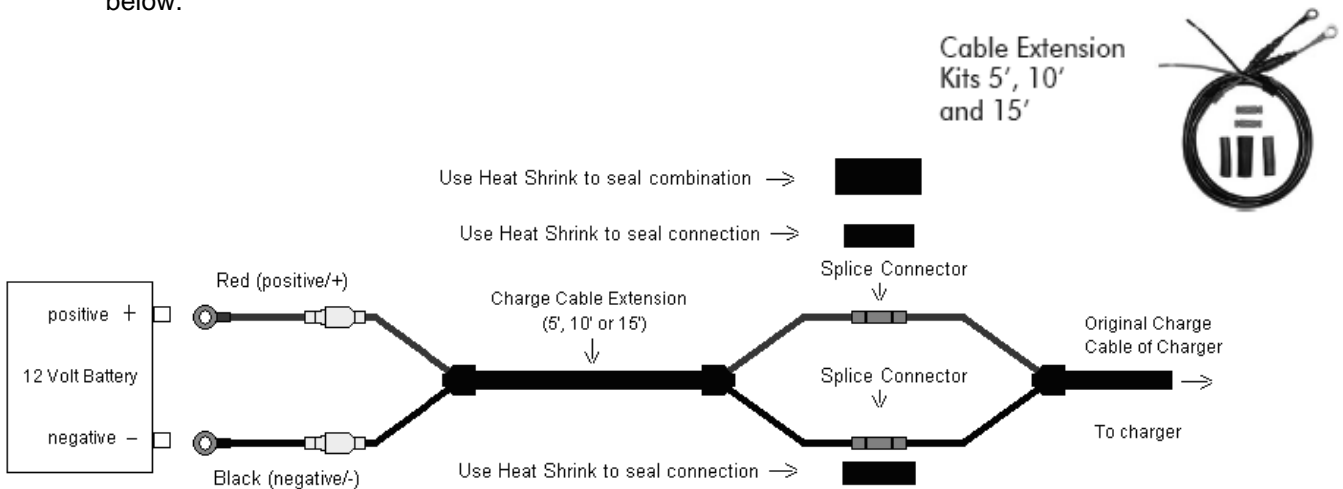

To connect the charger to the battery (batteries), route your charge cables from the charger to the batteries, being cautious to avoid sharp objects, and use the supplied wire ties to hold them securely and neatly in place.

Securely attach each charge cable independently to one 12V battery by connecting the red (positive/+) lead ring terminal to the positive (+) battery post and the black (negative/-) lead ring terminal to the negative (-) battery post. See picture below:

*The charger pictured is a **Professional Series Dual Pro**, which has two independent 15 amp outputs.*

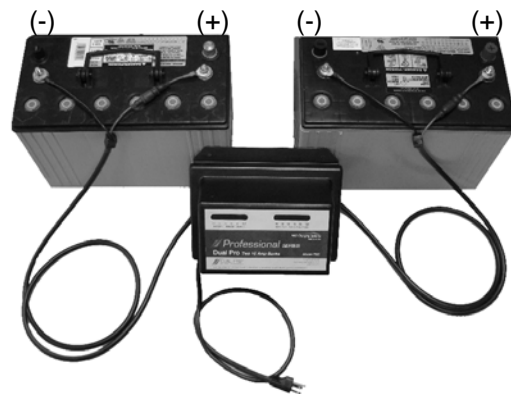

Connect a heavy duty UL approved extension cord to the power cord of your charger and then plug the extension cord into a nearby 120VAC GFI protected (Ground Fault Circuit Interrupt) outlet. You should now observe a red LED indication on each bank of the charger representing each individual battery being charged. The voltage of each battery will reflect the number of LED indicators illuminated.

When charging is complete, remove the extension cord from the 120VAC outlet first and then unplug the charger.

TROUBLE SHOOTING

PROBLEM: No LED indicators illuminate on the charger.

Solution Sequence: Check the AC power supply from its source through all connecting points up to the charger by using a meter or test light to confirm that current is being delivered to the charger.

PROBLEM: The Green (POWER) LED is illuminated, but the Red (CHARGING) LED and the Green (READY) LED are off.

Solution Sequence: This indicates that the charger does not recognize that it is connected properly to a battery that has at least 2Volts. With the AC power supply cord unplugged, check the ring terminals for correct polarity (Red to positive or +) and (Black to negative or -). Also check for corrosion free secure connections to the batteries. Check in-line fuses in charge cable for any signs of opening or corroded connections. Call the technical support group for further assistance (800.742.2420).

PROBLEM: The RED (CHARGING) LED remains illuminated for more than 16 hours and the Green (READY) LED does not come on.

Solution Sequence: This indicates that the battery is not reaching a sufficient voltage to indicate that the battery is fully charged. Disconnect AC power to the charging system. On multi bank chargers, remove the charge cable assembly of the affected bank from the battery and attach it to another battery in the boat. Take the original charge cable assembly from this battery and attach it to the battery from which you removed the first cable. Plug the charger in and observe the LED indications. If the rapid LED sequence (red to green repeatedly) occurs on a different bank of the charger, this confirms the existence of a battery problem.

On single bank systems, simply try the charger on another battery. If the charger now operates normally (steady red LEDs or changes to green and holds), this indicates a possible problem with the original battery.

If the same bank continues to malfunction, please call our technical support group (800.742.2740).

PROBLEM: The green (READY) LED was illuminated before disconnecting the power from the charger, but upon reconnection, the red (CHARGING) LED appears and remains on.

Solution Sequence: This is normal operating procedure for the system and simply indicates that a re-analysis of the battery status has been initiated and after a series of steps, the green LED will illuminate.

LIMITED WARRANTY

Pro Charging Systems, LLC (PCS) makes this Limited Warranty only to the original retail purchaser.

PCS warrants this battery charger for 18 months from the date of retail purchase against defective materials and/or workmanship. If such defects should occur, this unit will either be repaired or replaced at the discretion of the manufacturer. It is the responsibility of the original purchaser to return the charger along with proof of purchase, transportation, and/or any mailing or handling charges prepaid to the manufacturer or its authorized representative.

This limited warranty is void if the product is misused, improperly maintained, handled carelessly or incorrectly operated. Additionally, this warranty is void if the charger is disassembled, the charger's charge cables are cut, the power cord is cut off, the charger is altered without authorization from PCS, the serial number is removed, or repair is attempted by anyone other than an authorized representative.

PCS makes no other warranty other than this limited warranty and expressly excludes any implied warranty, including warranty for any incidental or consequential damages.

This is the only expressed limited 18 month warranty authorized by PCS and does not authorize anyone to assume or make any other obligation towards the product other than this three year Limited Warranty. Some states do not allow limitation of incidental or consequential damages.

This warranty gives you specific legal rights and you may also have other rights which vary from state to state.

Please call Pro Charging Systems, LLC (800.742.2740) for full warranty information and/or service.

Below are some of our other options in chargers and battery accessories. Call our technical support group for more detailed information or visit our web site www.dualpro.com.

Professional SERIES

Uni Pro
One 15 Amp
Bank



Dual Pro
Two 15 Amp
Banks



Tri Pro
Three 15 Amp
Banks



Quad Pro
Four 15 Amp
Banks



Sportsman SERIES

Uni Pro
One 10 Amp
Bank



Dual Pro
Two 10 Amp
Banks



Tri Pro
Three 10 Amp
Banks



Quad Pro
Four 10 Amp
Banks



Eagle Performance SERIES

Available in 12 to 48 Volts
and 9 to 25 Amps



Charge On The Run SERIES

12 Volt, Available in 1, 2 or 3
Banks



Go Charge

Maintainer/Charger
Available in 1.25 Amp and
2 Amp Units



For more information and products:

www.dualpro.com

Technical Support: 800.742.2740

Accessories

Cable Extension
Kits 5', 10'
and 15'



Remote Battery Status
Indicators 2 and 3 Banks

