

Easy Lift Equipment Co., Inc.

2 Mill Park Court, Newark, Delaware 19713 - Phone: 800-233-1800 / 302-737-7000

EAGLE-GRIP® 1 SERIES ATTACHMENTS OPERATION & MAINTENANCE INSTRUCTIONS

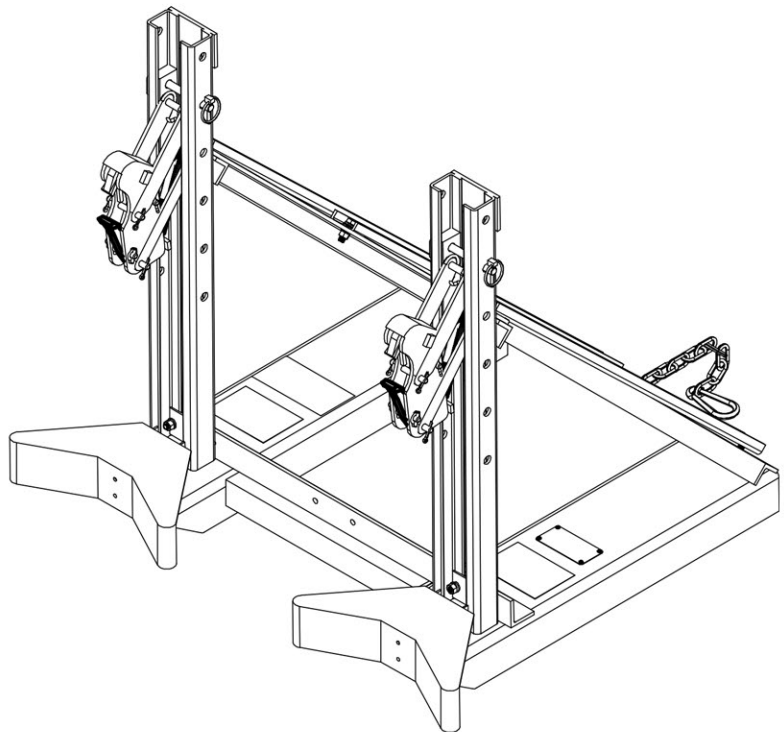
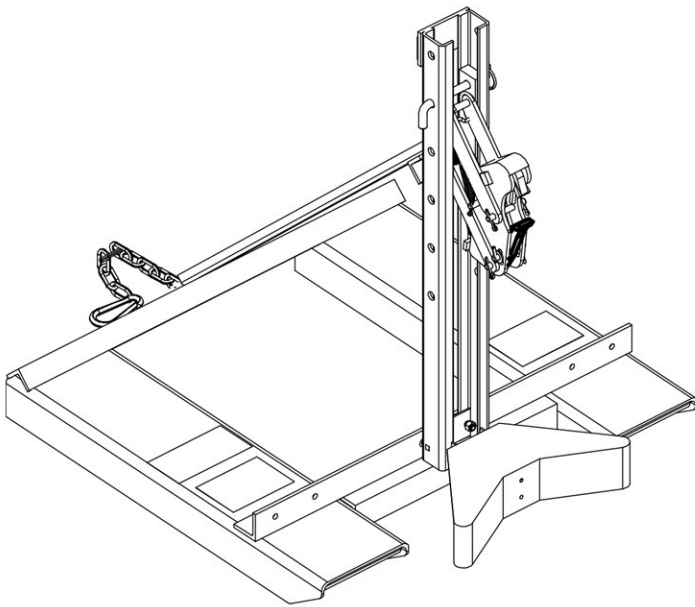

Easy Lift Equipment Co., Inc.

2 Mill Park Court, Newark, Delaware 19713 - Phone: 800-233-1800 / 302-737-7000

EASY LIFT EQUIPMENT EAGLE-GRIP® 1 SERIES ATTACHMENTS

INTRODUCTION

The Eagle-Grip® 1 series of lift truck attachments utilize a light duty single automatic clamping mechanism for handling any size steel, plastic, or fiber chimed drum. All models are knockdown units which bolt together. The fork pockets and safety chain provide a quick and easy connection to any lift truck. All Eagle-Grip® 1 models are recommended for light duty applications. The specification plate affixed to each attachment provides the following information: model number, serial number, attachment weight, and lifting capacity. **Please verify with your local forklift dealer that your lift truck, counter-balanced walkie stacker, or walkie straddle stacker is certified and tagged properly for this attachment.**

This manual contains information to help instruct operators on the proper use and maintenance of your Eagle-Grip® 1 series lift truck attachment. This manual should be made available to all operators who will use this equipment. Properly following the maintenance procedures will help ensure a safe and reliable service life. Do not operate this equipment until you have read and understand these instructions.

COMMISSIONING YOUR EAGLE-GRIP® 1 SERIES ATTACHMENT

1. Perform a visual inspection of the entire unit for damage.
2. Remove all packing materials, protective strapping, and wood shipping blocks. It is recommended to use protective eye gear when cutting any metal strapping. Then, using a company forklift, carefully drive the lift truck and position the forks inside the attachment fork pockets. Then lift and remove the attachment from the shipping pallet.
3. Secure the attachment to the lift truck by connecting the safety chain (unless your equipment has the Quick-Claw™ Safety Restraint System) to the forklift carriage. The end of the chain is equipped with a snap hook, so generally the chain is looped around the carriage and the snap hook is connected to the chain to form a loop.
4. The carriage mount version of this attachment will attach directly to any lift truck with an ITA Class II carriage. Lower the lift truck carriage close to the ground. Pull up the locking pin on the top rail of the attachment. Hook the top rail of the attachment over the top rail of the carriage. Slide the attachment so the cleat on the lower rail can pass through the cutout on the lower carriage rail and seat. Slide the attachment to the desired location along the rail. Push the locking pin back down to ensure the attachment is mounted securely to the lift truck carriage.

Easy Lift Equipment Co., Inc.

2 Mill Park Court, Newark, Delaware 19713 - Phone: 800-233-1800 / 302-737-7000

DAILY SAFETY INSPECTION

Do not operate your Eagle-Grip[®] 1 series attachment if you notice any unsafe condition(s) that may have been caused by an accident or malfunction. Immediately report this condition to your supervisor.

1. Perform a visual inspection, checking for loose or damaged springs and jaws.
2. Ensure that safety chain is properly attached to the lift truck carriage.
3. Ensure locking pins are pushed down and attachment is mounted securely to fork mount carriage.
4. Ensure the operator has read the manual and is properly trained to use the attachment.
5. Observe the condition of the equipment for any other malfunction or defect.

If any of these tests are failed, tag the unit properly to keep it out of service until the problem has been resolved.

SAFETY PRACTICES

1. Do not lift loads that exceed the rated capacity of the unit.
2. During transportation, only lift the drum(s) to the minimum height required for proper floor clearance while transporting the drum(s) to the required destination.
3. Keep hands and feet clear of the clamping head(s), lifting area in front of the unit, and the area underneath an elevated drum.
4. Be certain the clamping head(s) have made a secure connection with the chime of the drum before attempting to move or transport a load.
5. **Do not lift or suspend loads over people. Stay clear of suspended loads.**

Easy Lift Equipment Co., Inc.

2 Mill Park Court, Newark, Delaware 19713 - Phone: 800-233-1800 / 302-737-7000

WARNINGS

WARNING: Do not lift or suspend loads over people. Stay clear of suspended loads.

WARNING: Do not attempt to overload the attachment beyond its rated capacity, or raise the drum(s) beyond your lift truck's maximum lifting height.

WARNING: Never transport the attachment at its maximum lifting height.

WARNING: Keep hands and feet away from the pinch points, mast channels, clamp components and springs.

WARNING: Do not leave the attachment outside in inclement weather for extended periods. Allowing the attachment to get wet may result in damage to the equipment.

WARNING: Never leave the unit unattended with a suspended load.

WARNING: Never wash the unit down. The unit is designed to be wiped down by hand.

WARNING: Do not make alterations or modifications to the unit without Easy Lift Equipment authorization.

Easy Lift Equipment Co., Inc.

2 Mill Park Court, Newark, Delaware 19713 - Phone: 800-233-1800 / 302-737-7000

EAGLE-GRIP[®] 1 SERIES ATTACHMENTS OPERATING INSTRUCTIONS

TO ENGAGE AND TRANSPORT DRUMS:

1. Center the attachment clamping mechanism(s) with the horizontal center of drum(s) to be gripped and lifted. Lower the clamping mechanism(s) so they are below the chime of the drum(s). Drive the lift truck forward until the clamping mechanism(s) contact the drum(s).
2. While maintaining contact against the drum, raise the carriage of your lift truck so that the clamping mechanisms engage with the chimes of the drum(s). The weight of the drum on the lower clamping jaw(s) will activate the mechanism causing the upper jaw to clamp down on the chime, securing the drum.
3. The lift truck can now be driven to transport the drum(s). Remember, only lift the drum(s) to the minimum height required for proper floor clearance while transporting the drum(s) to their required destination.
4. To lower and release the drum(s), tilt the mast forward, then lower the carriage until the upper clamping jaw in the clamping mechanism has retracted completely. The lift truck operator can now back away.

TO ADJUST CLAMPING HEAD FOR VARIOUS DRUM HEIGHTS:

1. Lower the carriage as far as possible.
2. Remove the adjustment pin, and lower or raise the clamping mechanism up or down the mast so that the lower jaw is slightly below the rim or chime of the drum. It is advisable to have the cradle touching the lowest possible point of the drum that still permits engaging the drum. The second hole down on the mast is suited for 55-gallon drums.

Easy Lift Equipment Co., Inc.

2 Mill Park Court, Newark, Delaware 19713 - Phone: 800-233-1800 / 302-737-7000

ATTACHMENTS WITH QUICK-CLAW™ SAFETY RESTRAINT SYSTEM (IN LIEU OF A SAFETY CHAIN)

The patented Quick-Claw™ cam locks secure the attachment firmly to the forks of the lift truck. This option prevents the attachment from sliding off the forks during sudden stops, even when transporting a full load. This also eliminates the need for the operator to dismount and reboard the lift truck to secure or detach a standard safety chain. Unique rotating cams bind to the heel of each fork when the attachment is lifted off the ground. When the cam locks contact the floor, they conveniently release the attachment, allowing the operator to back-out and remove the forks from the attachment. The fork pockets on all Eagle-Grip 3 series attachments equipped with Quick-Claw cams are 43” in length. This 43” length is designed for use on lift trucks equipped with 42” length forks. The cam locks need to be in a position where the heel of the forks is between 1.25” and 1.75” thick. The lift truck forks should be inspected prior to using the Quick-Claw attachment to verify the fork thickness. In the event the lift truck is equipped with 48” forks, 49” fork pockets will be necessary for proper operation. If the attachment is not built to accommodate 48” length forks, the cam-locks on the Quick-Claw option may not function properly.

SCALE EQUIPPED MODELS (GRIP & WEIGH ATTACHMENTS)

If your equipment has a scale system, the indicator has already been factory calibrated and tested. The indicator has been disconnected and packaged separately for safe travel. Unpack the indicator(s) from the box and attach it/them to the mounting bracket. Once securely mounted, connect the indicator cable(s) to the unit cable by screwing the male and female ends together. Turn on the indicator(s) and ensure it/they reads zero before engaging a drum. Follow the instructions listed above for engaging a drum.

If handling drums containing liquids operators should allow the contents of the drum to settle prior to documenting drum weights. This will help ensure the most accurate possible measurements. Most scale indicators are set to display the weight in increments of 0.1 lb. (0.05 kg). To speed up the process it is recommended to set the indicator to a lower sensitivity. This can be achieved by programming the indicator to read in 0.5 lb. (0.25 kg) or 1.0 lb. (0.5 kg) increments. Doing so will require less time for the indicator to settle on a specific weight. All scale indicators are provided with a separate set of instructions that are packaged along with the indicator. Please read the scale indicator operations manual for more specific instructions of use.

Easy Lift Equipment Co., Inc.

2 Mill Park Court, Newark, Delaware 19713 - Phone: 800-233-1800 / 302-737-7000

Model	Capacity	Weight	H x L x W		Drums	Description
	(lbs/kg)	(lbs/Kg)	(inches)	(mm)	Handled	
EG1SCM-CM	750/340	49/23	32x14x14	813x356x356	1	Carriage Mount
EG1SCMSRC-CM	750/340	49/23	32x14x14	813x356x356	1	Carriage Mount
EG1SCM-F	750/340	120/55	36x34x31	889x864x787	1	Fork Mount
EG1SCMSRC-F	750/340	123/56	36x34x31	889x864x787	1	Fork Mount
EG1SCM-FQC	750/340	244/111	41x47x31	1016x1194x787	1	Fork Mount/Quick Claw
EG1SCMSRC-FQC	750/340	244/111	41x47x31	1016x1194x787	1	Fork Mount/Quick Claw
EG1SCM2-F	1500/680	175/80	35x34x38	889x864x965	1 or 2	Fork Mount
EG1SCMSRC2-F	1500/680	175/80	35x34x38	889x864x965	1 or 2	Fork Mount
EG1SCM2-FQC	1500/680	296/134	41x47x38	1016x1194x965	1 or 2	Fork Mount/Quick Claw
EG1SCMSRC2-FQC	1500/680	296/134	41x47x38	1016x1194x965	1 or 2	Fork Mount/Quick Claw
EG2LDCM-CM	1000/454	66/30	32x14x14	813x356x356	1	Carriage Mount
EG2LDCMSRC-CM	1000/454	66/30	32x14x14	813x356x356	1	Carriage Mount
EG2LDCM-F	1000/454	140/64	36x35x31	940x889x787	1	Fork Mount
EG2LDCMSRC-F	1000/454	140/64	36x35x31	940x889x787	1	Fork Mount
EG2LDCM-FQC	1000/454	261/119	41x47x31	1016x1194x787	1	Fork Mount/Quick Claw
EG2LDCMSRC-FQC	1000/454	261/119	41x47x31	1016x1194x787	1	Fork Mount/Quick Claw
EG2LDCM2-F	1500/680	200/91	36x35x38	940x889x965	1 or 2	Fork Mount
EG2LDCMSRC2-F	1500/680	200/91	36x35x38	940x889x965	1 or 2	Fork Mount
EG2LDCM2-FQC	1500/680	296/134	41x47x38	1016x1194x965	1 or 2	Fork Mount/Quick Claw
EG2LDCMSRC2-FQC	1500/680	296/134	41x47x38	1016x1194x965	1 or 2	Fork Mount/Quick Claw

* All Carriage Mount models are made to fit a Class II carriage unless otherwise specified

LOST LOAD CENTER: The distance from the tip of the forks to the center of the drum.

MODEL NUMBER

EG1SCM-CM & EG1SCMSRC-CM	22.00" from carriage to center of drum
	11.00" from carriage to beginning of drum
EG1SCM-F & EG1SCMSRC-F	14.50" to center of drum measurement
EG1SCM-FQC & EG1SCMSRC-FQC	14.50" to center of drum measurement
EG1SCM2-F & EG1SCMSRC2-F	14.50" to center of drum measurement
EG1SCM2-FQC & EG1SCMSRC2-FQC	14.50" to center of drum measurement

VERTICAL CENTER OF GRAVITY: The distance measured from the bottom of the attachment to the center point of the mast at which it balances.

MODEL NUMBER

EG1SCM-CM & EG1SCMSRC-CM	4.75" from carriage to center of CM
EG1SCM-F & EG1SCMSRC-F	8.00" with 29.5" Fork Pockets
EG1SCM-FQC & EG1SCMSRC-FQC	9.00" with 43" Fork Pockets
EG1SCM2-F & EG1SCMSRC2-F	11.00" with 29.5" Fork Pockets
EG1SCM2-FQC & EG1SCMSRC2-FQC	11.00" with 43" Fork Pockets

HORIZONTAL CENTER OF GRAVITY:

The distance or point that is measured between the beginning of the fork pockets to the end of the attachment which the attachment balances.

MODEL NUMBER

EG1SCM-CM & EG1SCMSRC-CM	14.50" from bottom of CM
EG1SCM-F & EG1SCMSRC-F	18.75" with 29.5" Fork Pockets
EG1SCM-FQC & EG1SCMSRC-FQC	22.75" with 43" Fork Pockets
EG1SCM2-F & EG1SCMSRC2-F	31.50" with 29.5" Fork Pockets
EG1SCM2-FQC & EG1SCMSRC2-FQC ⁷	29.50" with 43" Fork Pockets

Easy Lift Equipment Co., Inc.

2 Mill Park Court, Newark, Delaware 19713 - Phone: 800-233-1800 / 302-737-7000

LOST LOAD CENTER: The distance from the tip of the forks to the center of the drum.

MODEL NUMBER

EG2LDCM-CM & EG1SCMSRC-CM	22.00" from carriage to center of drum
	11.00" from carriage to beginning of drum
EG2LD CM-F & EG2LD CMSRC-F	14.50" to center of drum measurement
EG2LD CM-FQC & EG2LD CMSRC-FQC	14.50" to center of drum measurement
EG2LD CM2-F & EG2LD CMSRC2-F	14.50" to center of drum measurement
EG2LD CM2-FQC & EG2LD CMSRC2-FQC	14.50" to center of drum measurement

VERTICAL CENTER OF GRAVITY: The distance measured from the bottom of the attachment to the center point of the mast at which it balances.

MODEL NUMBER

EG2LD CM-CM & EG2LD CMSRC-CM	4.75" from carriage to center of CM
EG2LD CM-F & EG2LD CMSRC-F	8.00" with 29.5" Fork Pockets
EG2LD CM-FQC & EG2LD CMSRC-FQC	9.00" with 43" Fork Pockets
EG2LD CM2-F & EG2LDCMSRC2-F	11.00" with 29.5" Fork Pockets
EG2LD CM2-FQC & EG2LD CMSRC2-FQC	11.00" with 43" Fork Pockets

HORIZONTAL CENTER OF GRAVITY:

The distance or point that is measured between the beginning of the fork pockets to the end of the attachment which the attachment balances.

MODEL NUMBER

EG2LD CM-CM & EG2LD CMSRC-CM	14.50" from bottom of CM
EG2LD CM-F & EG2LD CMSRC-F	18.75" with 29.5" Fork Pockets
EG2LD CM-FQC & EG2LD CMSRC-FQC	22.75" with 43" Fork Pockets
EG2LD CM2-F & EG2LD CMSRC2-F	31.50" with 29.5" Fork Pockets
EG2LD CM2-FQC & EG2LDCMSRC2-FQC	29.50" with 43" Fork Pockets

ALL EG1 & EG2L MODELS WITHOUT QUICK-CLAW™ CAM LOCK SYSTEM

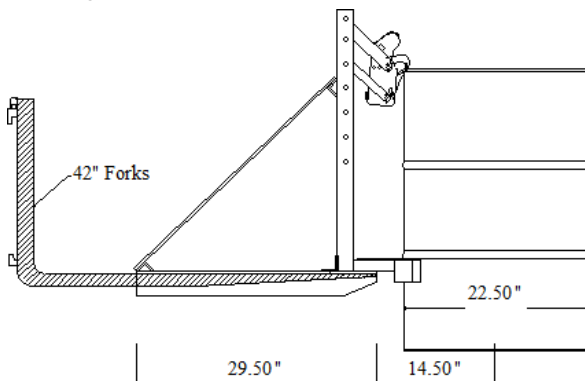

ALL EG1 & EG2L WITH QUICK-CLAW™ CAM LOCK SYSTEM

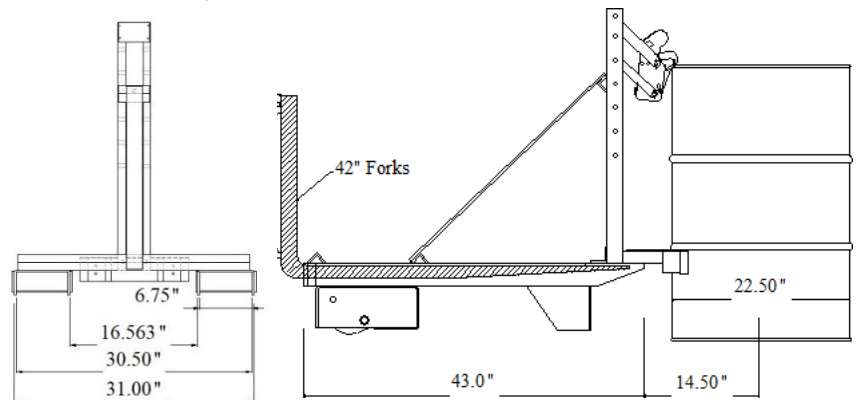

FOR PARTS & SERVICE CALL:

Easy Lift Equipment Co., Inc.
2 Mill Park Ct.
Newark, DE 19713

Phone: 800-233-1800: 302-737-7000
Website: www.easylifteqpt.com
Email: sales@easylifteqpt.com

Easy Lift Equipment Co., Inc.

2 Mill Park Court, Newark, Delaware 19713 - Phone: 800-233-1800 / 302-737-7000

CLAMPING HEAD OR ATTACHMENT PREVENTATIVE MAINTENANCE EXCHANGE & REFURBISHMENT PROGRAM

This service is designed to provide customers with an easy-to-use preventative maintenance & refurbishment program to achieve the best performance and maximum service life. The clamping mechanism(s) should have regular preventative maintenance service in addition to required visual inspections, belt replacement, and monthly lubrication. The intervals between services are dependent upon usage but should generally be done at least once every year.

Loaner clamping head(s), or full attachment are provided free of charge; however, the customer is responsible for all shipping costs incurred. Loaner attachments and clamping mechanisms are finished in a different color to ensure identification as loaner units.

HOW IT WORKS:

- Contact Easy Lift Equipment or your local dealer to obtain a return authorization number for your clamping head(s) or full attachment. If needed, a loaner clamping head(s), or attachment will be shipped to your site to minimize down time while your equipment is being serviced.
- Clamping head(s) only: remove the clamping head assembly from mast by removing the circle cotter clip from the adjustment pin and pulling the adjustment pin out. Slide the entire clamping head assembly up and out of the mast and reinsert the adjustment pin and circle cotter pin into the clamping head(s).
- Ship the original clamping head(s) or full attachment to Easy Lift Equipment in the same box, container, or pallet that the loaner was received in/on. Be sure to display the return authorization number and company name on the outside of the box, container, or pallet.
- The clamping head(s) or full attachment will be disassembled and assessed so a maintenance quote can be provided for approval. Costs are determined by the required parts, labor, and requested services or additional features.

SCOPE OF WORK TO BE PERFORMED: Clean and lubricate all necessary pins. (Sandblasting, welding, and re-powder coating is available upon request). Replace springs, jaws, cotter pins, or any worn parts. Reassemble clamping head(s) or full attachment.

- Upon completion, approval, and payment, the clamping head(s) or full attachment will be returned to the customer. The loaner clamping mechanism or attachment should be promptly returned to Easy Lift Equipment. If the equipment is not in transit within 5 days from receipt date of the refurbishment equipment, the loaner company authorizes Easy Lift Equipment Co., Inc. to process the transaction as a sale and bill applicable charges.

Payment Terms: Net 30 (with approved credit)

Payment Options: Check, EFT, American Express, Visa, MasterCard, or Discover

The customer is responsible for all charges including but not limited to:

1. Parts & labor required for refurbishment or preventative maintenance.
2. Shipping to and from the loaner location.
3. Loss, damage, or repair(s) to the equipment. The loaner company shall notify Easy Lift Equipment Co., Inc. of any damage(s) to the equipment. The loaner company will be responsible for loss or damage to equipment.

Ownership: Easy Lift Equipment Co., Inc. retains 100% ownership of the loaner equipment

Easy Lift Equipment Co., Inc.

2 Mill Park Court, Newark, Delaware 19713 - Phone: 800-233-1800 / 302-737-7000

Operator's Daily Checklist

Eagle-Grip® Fork Attachment with Eagle-Grip® Clamping Head(s)

Inspections Performed by: _____

Note: This inspection must be made by the equipment operator **daily** at the start of the shift. Check (✓) the appropriate "OK" or "Needs Repair" field.

This Daily Checklist is intended to help verify that the equipment is in proper working order each day.

More thorough Weekly, Monthly and Yearly Maintenance schedules should still be followed.

VISUAL CHECK		DATE: / / / / / / / / / / / / / / / /													
		OK	Needs Repair	OK	Needs Repair	OK	Needs Repair	OK	Needs Repair	OK	Needs Repair	OK	Needs Repair	OK	Needs Repair
VISUAL CHECK: FRAME & MAST(S)	DATA PLATES & WARNING DECALS - Data Plates & Warning Decals are affixed to the unit and in good condition														
	DAMAGE - Look for bent, dented or broken parts. This includes frame welds, bolted connections, belts, fork pockets or Quick-Claw (if applicable)														
	SAFETY CHAIN OR QUICK-CLAW - Verify that all the components of the Safety Chain or Quick-Claw (if applicable) are free of damage or missing components														
	CARRIAGE MOUNT(S) - Verify that the Carriage Mount(s) are free of damage and properly secured onto the Attachment Frame														
	BELT(S) - Verify proper belt tension (contact Easy Lift Equipment for details)														
VISUAL CHECK: EG CLAMP(S)	CLAMP DAMAGE - Look for bent, dented or broken clamp components. This includes the clamp outer and inner housings, clamping jaws, retaining pins, cotter pins, and springs														
	CLAMP PINS - Confirm that all retaining pins, roll pins and cotter pins are accounted for and secure														
VISUAL: SCALE	SCALE SYSTEM & PRINTER - If applicable, confirm that the scale and printer as well as all wires, lines and cables are in good condition and properly connected														

Checklist Continued on Next Page

Easy Lift Equipment Co., Inc.

2 Mill Park Court, Newark, Delaware 19713 - Phone: 800-233-1800 / 302-737-7000

Operator's Daily Checklist (cont.)

Eagle-Grip® Fork Attachment with Eagle-Grip® Clamping Head(s)

OPERATIONAL CHECK		DATE: / /		/ /		/ /		/ /		/ /		/ /	
		OK	Needs Repair	OK	Needs Repair	OK	Needs Repair	OK	Needs Repair	OK	Needs Repair	OK	Needs Repair
OPERATIONAL CHECK: FRAME & MAST(S)	FORK POCKETS - Verify that the forks of your lift truck fit accordingly into the fork pockets of your Eagle-Grip Attachment												
	SAFETY CHAIN - Confirm that the Safety Chain is properly connected to the carriage of your lift truck using either the Cam Lock or Snap Hook systems												
	QUICK-CLAW - When raising the Attachment off the ground, ensure that the Cam Locks of the Quick-Claw Safety Restraint System (if applicable) properly secures to your lift truck forks												
EAGLE-GRIP	EAGLE-GRIP CLAMPING HEAD - Verify that the Eagle-Grip Clamping Head(s) engage and disengage a drum/drums properly. Only lift the "test" drum(s) to the minimum height required while completing this test												
SCALE & PRINTER	SCALE SYSTEMS & PRINTERS - If applicable, power up the scale and printer. Ensure the scale and printer are in proper working order												

List the details of all required repairs in the comments section below. Then, **tag and decommission the equipment for safety.**

Comments (items needing repair or adjustment): _____

Caution – If the equipment is found to be in need of repair or in any way unsafe, or contributes to an unsafe condition, the matter shall be reported immediately to the designated supervisor, and the attachment shall not be operated until it has been restored to a safe operating condition. If during operation, the attachment becomes unsafe in any way, the matter shall be reported immediately to the designated supervisor, and the attachment shall not be operated until it has been restored to safe operating condition. Do not make repairs or adjustments unless specifically authorized to do so.

Easy Lift Equipment Co., Inc.

2 Mill Park Court, Newark, Delaware 19713 - Phone: 800-233-1800 / 302-737-7000

EAGLE-GRIP® ATTACHMENT MAINTENANCE SCHEDULES

Easy Lift Equipment recommends the following maintenance intervals.
Failure to do so could cause the equipment not to work as intended.

MONTHLY INTERVALS

Eagle-Grip Frame	Thoroughly check the frame and masts for any cracked welds or structural damage.
Eagle-Grip Fork Pockets	Flip the attachment forward & thoroughly inspect the fork pocket ends for cracked welds or structural damage.
Safety Chain (Snap Hook or Cam Lock)	Thoroughly check the safety chain, as well as the snap hook or cam lock systems for wear, damage and/or missing components.
Belts	Thoroughly check belts (if applicable) for wear or damage. Also ensure proper tension. (contact Easy Lift Equipment for details)
Eagle-Grip Clamping Head(s)	Thoroughly inspect the clamping head(s) for bent, dented or broken clamp components. This includes the clamp outer and inner housings, clamping jaws, retaining pins, cotter pins, and springs.
Eagle-Grip Clamping Head(s)	Lubricate clamping mechanisms For both Non-FDA & FDA Equipment: WD-40, Berkebile White Lithium Grease or comparable

YEARLY INTERVALS

Eagle-Grip Clamping Head(s) Springs	Replace all clamping mechanism springs. See cooresponding PM Kit for details.
--	---

EVERY THREE YEARS*

Eagle-Grip Clamping Head(s) Pins & Links	Replace all clamping mechanism pins and links. See cooresponding PM Kit for details.
---	--

* If regularly handling over 1,000 drums weekly, it is recommended to conduct this maintenance inspection/replacement every 18 months.

Easy Lift Equipment Co., Inc.

2 Mill Park Court, Newark, Delaware 19713 - Phone: 800-233-1800 / 302-737-7000

EASY LIFT EQUIPMENT WARRANTY POLICY FOR MODELS WITH PREFIXES: ED/ER/EL/ELDR/EG & RCR

Easy Lift Equipment (“ELE”) warrants each new product to be free from factory material and workmanship defects, under normal use with proper maintenance, for a period of 12 months. Warranty coverage for this warranty period is provided by authorized dealers and includes parts. Labor is covered for the same periods of 12 months as outlined above. Please call ELE for the authorized repair dealer in your area.

ELE shall be the sole judge of the validity of any claim or defect and may elect to make any replacement or repair of any part thereof that it has agreed to be defective. Wearable Items such as: hoses, bearings, belts, brushes, seals, lift motors, clamp motors, relays, fuses, springs and wheels are wear items not covered under the warranty policy. ELE assumes no responsibility whatsoever to work done, parts replaced, or expenses incurred not specifically authorized by ELE. Normal maintenance or replacement of service items is not covered by this warranty. No warranty claims will be considered for customers with any delinquent outstanding balance. When batteries, battery chargers, scale printers or scale indicators are purchased from ELE with the equipment, the original manufacturer’s warranty applies.

WARRANTY LIMITATION/DISCLAIMERS:

Easy Lift Equipment reserves the right to void warranty coverage if the unit has been overloaded beyond rated capacity; damaged due to: abuse, misuse, neglect, accidents, freight damage, improper usage, improper repair, and/or improper storage; or any modification or repair conducted in a manner not approved by Easy Lift Equipment. Equipment used in freezers, abrasive, corrosive, and/or excessively moist conditions must be properly equipped for the environment to ensure the warranty is not voided. Warranty questions and claims should be directed to our customer service department. ELE customer service representatives will help you assess and resolve the claim or assist you in contacting the local authorized dealer or representative. The warranty described here shall constitute the sole remedy of the authorized dealer and/or the initial purchaser. ELE neither assumes nor authorizes any person to assume for it any other obligation or responsibility in connection with this product warranty. In no event shall ELE be responsible for direct, indirect, special or consequential damages or any other delay or any economic or commercial loss resulting from Easy Lift Equipment’s performance or non-performance under this warranty. This warranty is expressly in lieu of all warranties, obligations or responsibilities of ELE dealers or other authorized source, expressed, implied or statutory.

SUBMITTING CLAIMS:

To make a claim under this policy, please contact Easy Lift Equipment for assistance. We can be reached by calling 800-233-1800 ext. 4 for customer service or by writing to sales@easylifteqpt.com. Do not return defective parts unless a return authorization (RA) has been provided requesting the return. If requested, we will provide shipping information on how the part should be returned and bear the expense for the return shipping, if the part is proven to be defective. A copy of the work order made at the time of the repair and parts claimed under warranty may be requested for ELE’s inspection.

ORDERING PARTS:

Easy Lift Equipment’s parts are distributed through our customer service department and ship the same day as ordered whenever possible. You will be well taken care of whenever parts, adjustments or repairs are needed. **When contacting ELE, please be sure to state the model and serial number for the equipment.** There is no cost for electronic copies of replacement manuals, parts lists and other general information containing part numbers and nomenclature. Most manuals contain parts pricing, but it is not guaranteed to be valid as parts pricing can change at any time without notice. Any customer service representative can provide timely parts quotations upon request. Adherence to above procedure will save time and provide prompt assistance when it counts. You are of course always welcome to bring to us any questions, comments or recommendations pertaining to your Easy Lift Equipment products.

MANUFACTURER CONTACT INFORMATION:

Easy Lift Equipment Co., Inc.
2 Mill Park Ct.
Newark, DE 19713
Email: sales@easylifteqpt.com

Phone: 800-233-1800: 302-737-7000
Fax: 302-737-7333
Website: www.easylifteqpt.com

EASY LIFT EQUIPMENT FIBER DRUM EG1 CLAMPING PROCEDURE

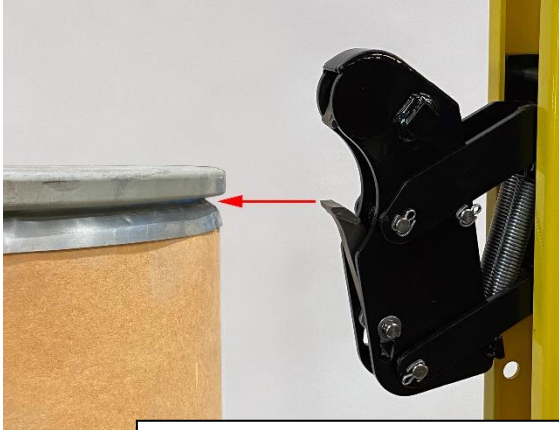

1. Raise the clamping mechanism until the lower jaw is just high enough to contact the metal skirt just below the locking band.

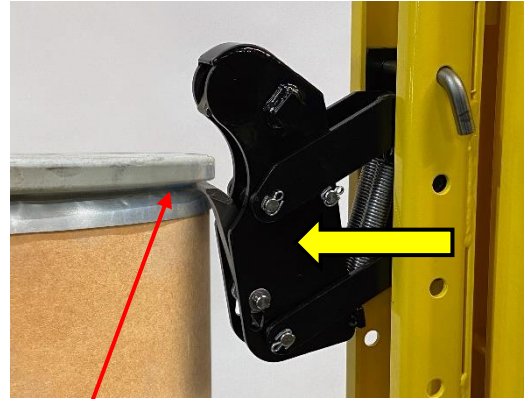

2. Then move the clamping mechanism forward so the lower jaw contacts the metal skirt under the drum's locking band and proceed to elevate the drum upward.



3. Maintain slight forward momentum while raising the drum so the lower clamping jaw maintains contact with the metal skirt. Do not allow the lower jaw to contact the paper portion of the fiber drum when elevating the drum.

IMPORTANT:

It is important that the lower jaw does not contact the paper portion of the drum when raising the clamping mechanism. Keep the lower jaw away from the paper portion of the drum until the lower jaw of the clamping mechanism is high enough to contact the metal skirt below the locking band.

Then push the clamping mechanism forward to contact the skirt. Once contact has been made, proceed to elevate the clamping mechanism. If the lower jaw contacts the paper portion of the drum when elevating the drum, the clamping mechanism will attempt to clamp the drum in this position and miss or tear the skirt. If this is done incorrectly, lower the clamp and try again. The clamping mechanism can also grip the drum without the lid and locking band.

EASY LIFT EQUIPMENT FIBER DRUM EG2L CLAMPING PROCEDURE

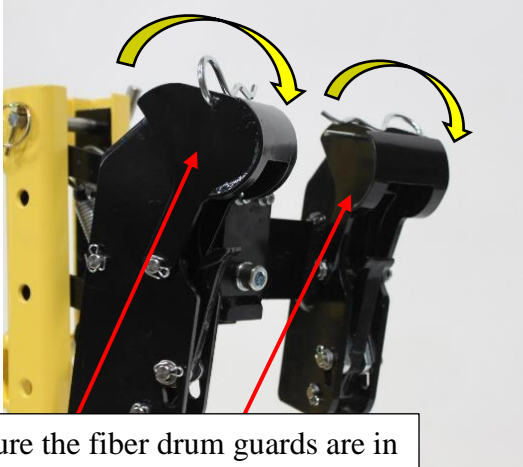

1. Ensure the fiber drum guards are in the forward position (closer to the clamp) and the cotter pins are locking the guards in place. The guards should always be in this position when handling fiber drums. The guards can be in the rearward position (closer to the mast) when handling steel or plastic drums.

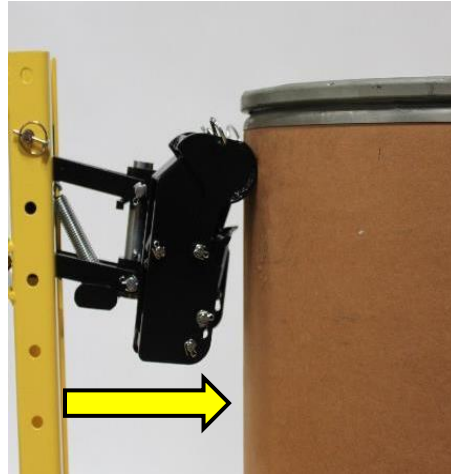

2. Push the unit forward so the fiber drum guards are contacting the paper portion of the drum.

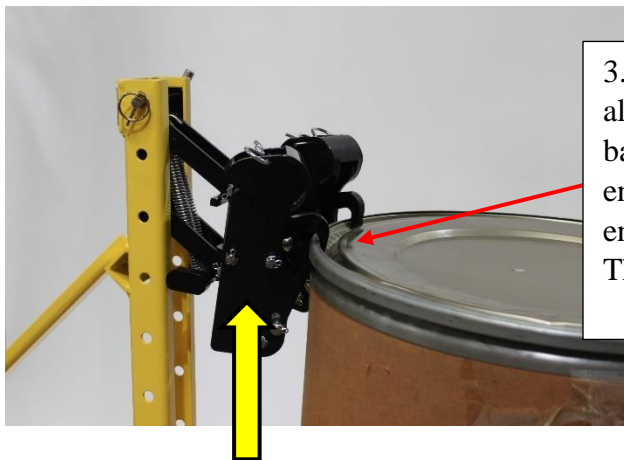

3. Elevate the clamping mechanism(s), allowing them to engage the locking band. After the clamp has fully engaged continue elevating the drum enough to ensure safe floor clearance. The drum can now be transported.

IMPORTANT:

The fiber drum guards, when in the forward position, are designed to prevent the clamp from damaging the fragile paper portion of fiber drums. Great care should still be taken to ensure the clamping mechanism only contacts the metal skirt and locking band.

LIGHT DUTY SINGLE DRUM FRAME ASSEMBLY

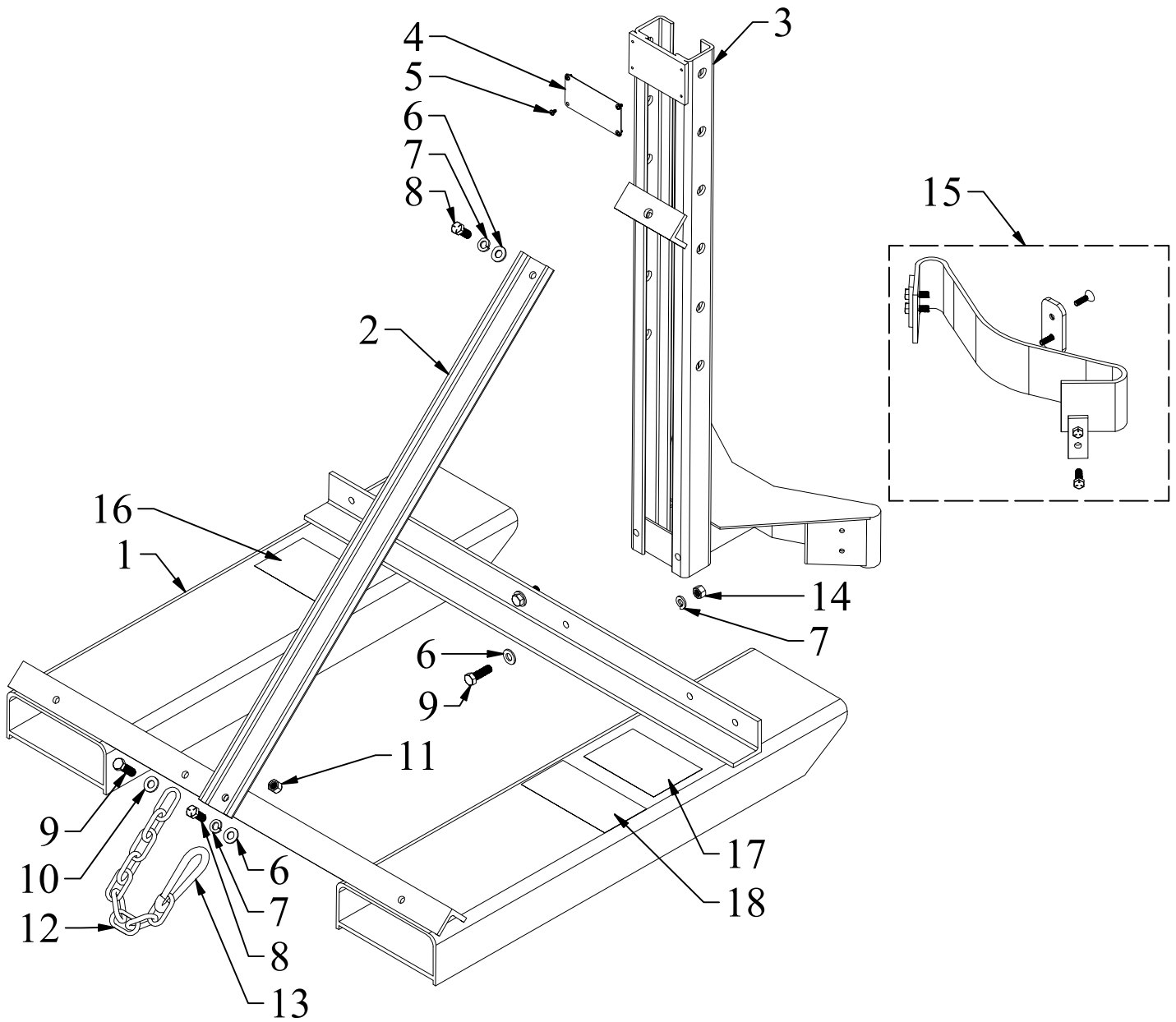

LIGHT DUTY SINGLE DRUM FRAME PARTS LIST

<u>ITEM</u>	<u>PART NO.</u>	<u>DESCRIPTION</u>	<u>QTY</u>
1	96026	Fork Pockets for Slide on Mounting	1
2	60021	Vertical Brace, Frame to Slide-on Mounting	1
3	7002	Mast	1
4	MCL007031	Specification Plate	1
5	6 x 1/4 RUDS-SS	6 x 1/4 Round Head U Drive Screw (stainless steel)	4
6	3/8 FW SAE	3/8 Flat Washer SAE (zinc)	4
7	3/8 LW	3/8 Lock Washer (zinc)	4
8	3/8-16 x 1 HHCS-8	3/8-16 x 1 Hex Head Cap Screw Grade 8 (yellow zinc)	2
9	3/8-16 x 1 1/4 HHCS-8	3/8-16 x 1 1/4 Hex Head Cap Screw Grade 8 (yellow zinc)	3
10	3/8 FW	3/8 Flat Washer (zinc)	1
11	3/8-16 NLN	3/8-16 Nylon Locking Nut (zinc)	1
12	12E312-0003	36" 5/16" Chain Zinc Plated Proof Coil Chain	1
13	SNAP2450-375NE	3/8" Snap Hook	1
14	3/8-16 HN	3/8-16 Finished Hex Nut (zinc)	2
15	5516E	Optional: Belt Cradle Kit (includes all hardware)	1
<u>DECALS</u>			
16	ADART002	Attention Read Operations Manual Decal	1
17	ADART750	750lbs Capacity Sticker	1
18	ADART015	ELE Address Decal (Horizontal)	1

LIGHT DUTY DOUBLE DRUM FRAME ASSEMBLY

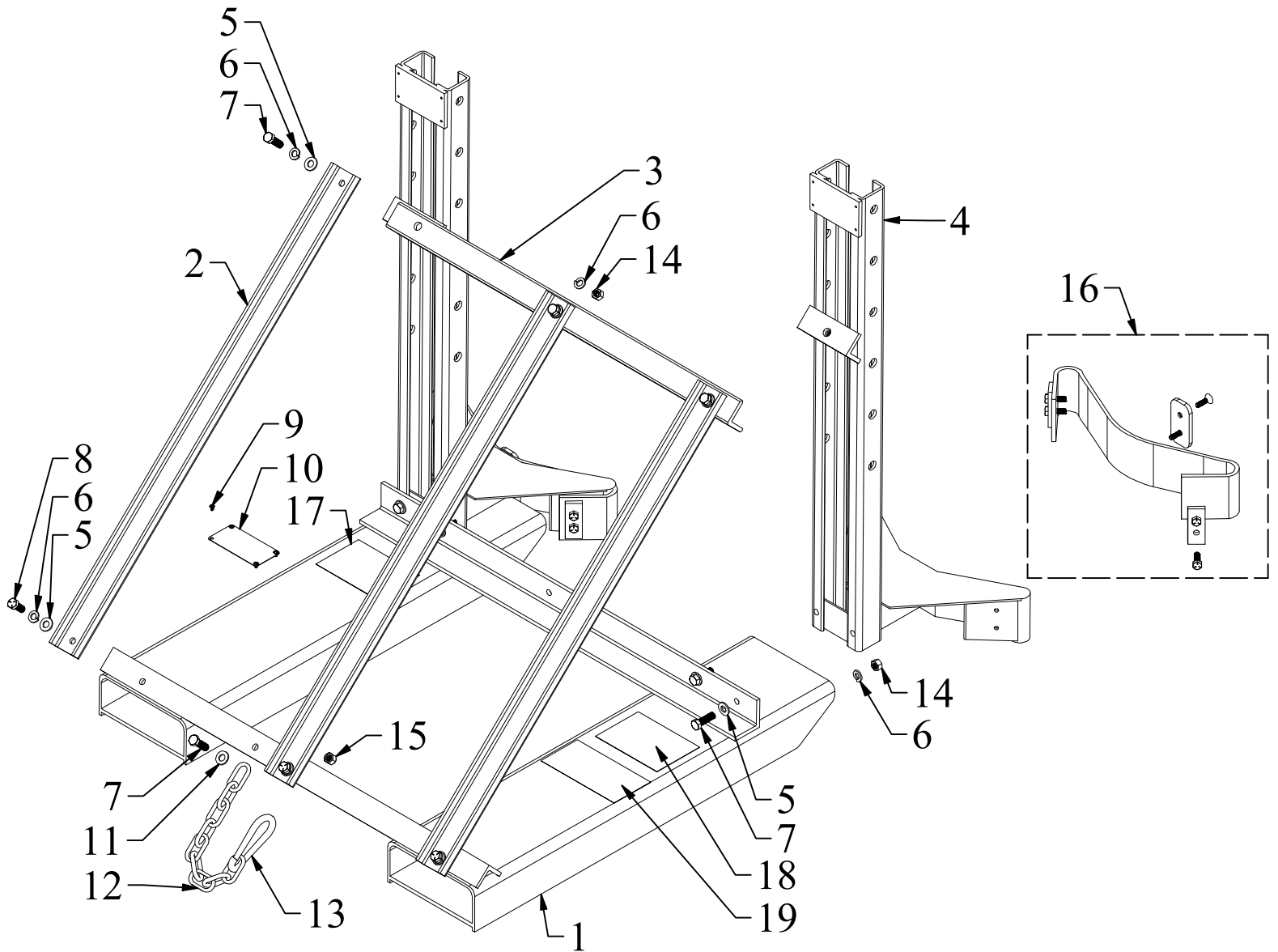

LIGHT DUTY DOUBLE DRUM FRAME PARTS LIST

<u>ITEM</u>	<u>PART NO.</u>	<u>DESCRIPTION</u>	<u>QTY</u>
1	96026	Fork Pockets for Slide on Mounting	1
2	60021	Vertical Brace, Frame to Slide-on Mounting	3
3	7002-1	Horizontal Brace Mount	1
4	7002	Mast	2
5	3/8 FW SAE	3/8 Flat Washer SAE (zinc)	10
6	3/8 LW	3/8 Lock Washer (zinc)	11
7	3/8-16 x 1 1/4 HHCS-8	3/8-16 x 1 1/4 Hex Head Cap Screw Grade 8 (yellow zinc)	8
8	3/8-16 x 1 HHCS-8	3/8-16 x 1 Hex Head Cap Screw Grade 8 (yellow zinc)	3
9	6 x 1/4 RUDS-SS	6 x 1/4 Round Head U Drive Screw (stainless steel)	4
10	MCL007031	Specification Plate	1
11	3/8 FW	3/8 Flat Washer (zinc)	1
12	12E312-0003	36" 5/16" Chain Zinc Plated Proof Coil Chain	1
13	SNAP2450-375NE	3/8" Snap Hook	1
14	3/8-16 HN	3/8-16 Finished Hex Nut (zinc)	5
15	3/8-16 NLN	3/8-16 Nylon Locking Nut (zinc)	1
16	5516E	Optional: Belt Cradle Kit (includes all hardware)	2
<u>DECALS</u>			
17	ADART002	Attention Read Operations Manual Decal	1
18	ADART1500	1500lbs/680kg Capacity Sticker	1
19	ADART015	ELE Address Decal (Horizontal)	1

EG1 LIGHT DUTY SINGLE CLAMPING MECHANISM ASSEMBLY

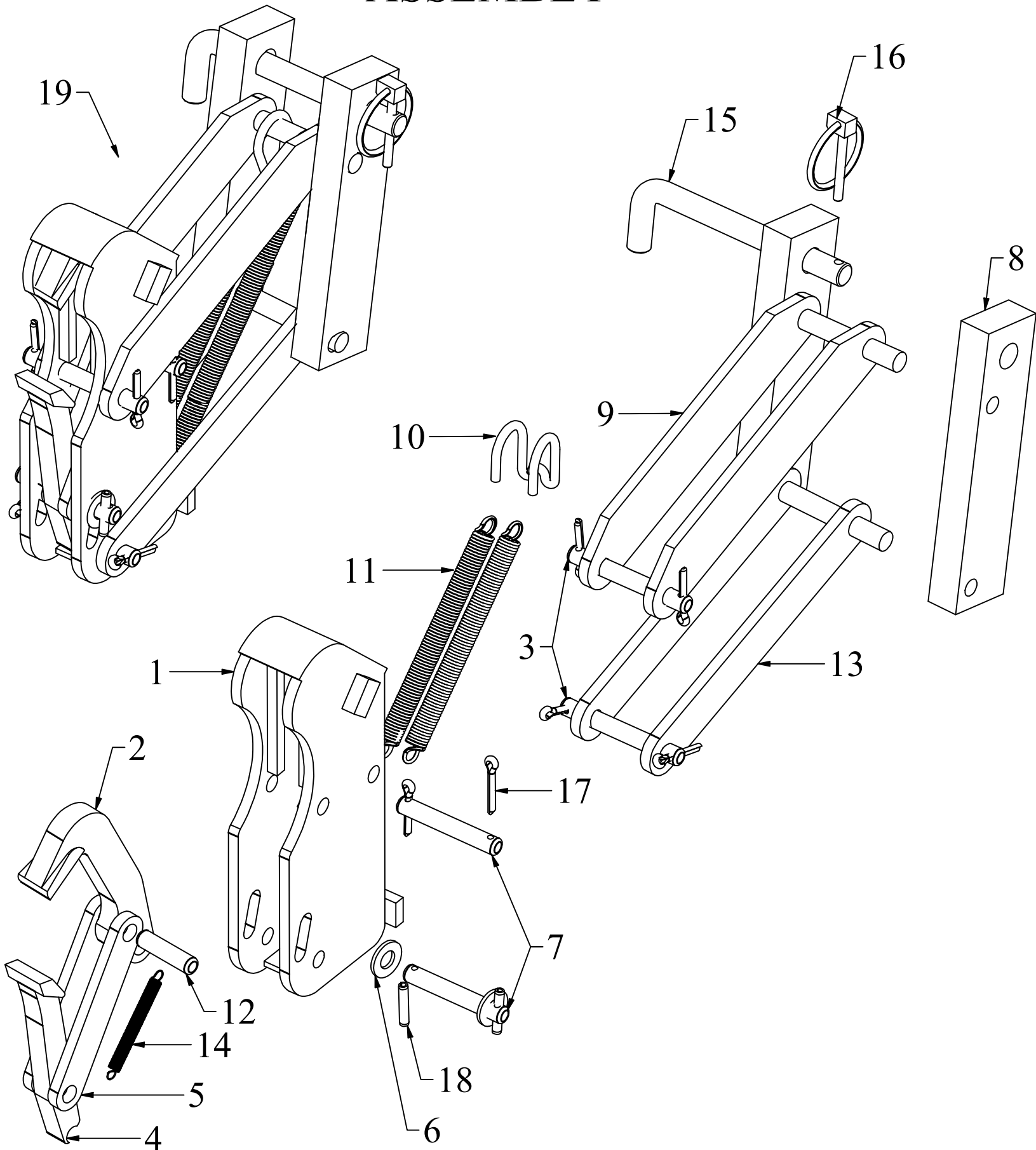

EG1 LIGHT DUTY SINGLE CLAMPING MECHANISM PARTS LIST

<u>ITEM</u>	<u>PART NO.</u>	<u>DESCRIPTION</u>	<u>QTY</u>
1	6302	Housing (Black Powder Coating)	1
1	6302SS	Housing (Stainless Steel)	1
2	9107SS	Stainless Steel Upper Jaw (Spark Resistant)	1
3	15104-1SS	3/8" x 2.242" Pin, Fibre Guard, Housing to Clevis (stainless steel)	2
4	7107SS	Stainless Steel Lower Jaw (Spark Resistant)	1
5	13009-1	Link, Jaw to Jaw (zinc)	2
5	13009-1SS	Link, Jaw to Jaw (stainless steel)	2
6	C616 FW-SS	C616 Flat Washer (stainless steel)	2
7	16104-1SS	3/8" x 1.770" Pin, Upper Jaw Link (stainless steel)	2
8	8002	Adjustment Slide (FDA Black Powder Coating)	2
8	8002SS	Adjustment Slide (Stainless Steel)	2
9	5912	Upper Clevis 8" (FDA Black Powder Coating - 5" Belt Cradle)	1
9	5912SS	Upper Clevis 8" (Stainless Steel - 5" Belt Cradle)	1
9	5912S	Upper Clevis 6" (FDA Black Powder Coating - 3" Belt Cradle)	1
9	5912SS-S	Upper Clevis 6" (Stainless Steel - 3" Belt Cradle)	1
10	8996-2	Clevis Spring Hook (Stainless Steel)	1
11	8206	Clevis Spring (zinc)	2
12	41041SS	3/8" x 1" Pin, Upper Jaw to Link, short (stainless steel)	1
13	6912	Lower Clevis 7 1/2" (FDA Black Powder Coating - 5" Belt Cradle)	1
13	6912SS	Lower Clevis 7 1/2" (Stainless Steel - 5" Belt Cradle)	1
13	6912S	Lower Clevis 5 1/2" (FDA Black Powder Coating - 3" Belt Cradle)	1
13	6912SS-S	Lower Clevis 5 1/2" (Stainless Steel - 3" Belt Cradle)	1
14	1206	Spring, Jaw to Housing (stainless steel)	1
15	10204-1SS	1/2" x 4-1/2" Adjusting Pin (stainless steel)	1
16	HANG-1	3/16 x 1-1/4 Shank Lynch Pin "Hang 1" (9016)	1
17	3006-CP	Cotter Pin, 1/8" x 3/4" (zinc)	6
17	1/8 x 3/4 CP-SS	1/8 x 3/4 Cotter Pins (stainless steel)	6
18	5/32 x 1/2 Roll Pin	Stainless Steel 5/32 x 1/2 Roll Pin	2
	CRC 05037	White Lithium Grease Can	1
<u>FULL ASSEMBLIES</u>			
19	9004	EG1 Single Clamping Mechanism (FDA Black Powder Coating - 5" Belt Cradle)	
19	9004S	EG1 Single Clamping Mechanism (FDA Black Powder Coating - 3" Belt Cradle)	
19	9004SRC	EG1 Single Clamping Mechanism (Stainless Steel Housing - Spark Resistant - 5" Belt Cradle)	
19	9004SRC-S	EG1 Single Clamping Mechanism (Stainless Steel Housing - Spark Resistant - 3" Belt Cradle)	
19	9004SS	EG1 Single Clamping Mechanism (Stainless Steel - Spark Resistant - 5" Belt Cradle)	
19	9004SS-S	EG1 Single Clamping Mechanism (Stainless Steel - Spark Resistant - 3" Belt Cradle)	
<u>PREVENTATIVE MAINTENANCE KITS</u>			
	EG1PMKIT	EG1 Preventative Maintenance Kit	
	EG1BCPMKIT	EG1 Preventative Maintenance Kit w/ Belt Cradle	

**EG1 SINGLE CLAMPING MECHANISM
PREVENTATIVE MAINTENANCE KIT BREAKDOWN**

EG1 PREVENTATIVE MAINTENANCE KIT			
<u>ITEM</u>	<u>PART NO.</u>	<u>DESCRIPTION</u>	<u>QTY</u>
11	8206	Clevis Spring (zinc)	2
14	1206	Spring, Jaw to Housing (stainless steel)	1
16	HANG-1	3/16 x 1-1/4 Shank Lynch Pin "Hang 1" (9016)	1
17	3006-CP	Cotter Pin, 1/8" x 3/4" (zinc)	6
18	5/32 x 1/2 Roll Pin	Stainless Steel 5/32 x 1/2 Roll Pin	2
	WLG	12oz White Lithium Grease	1
ALL ABOVE ITEMS PART NUMBER: EG1PMKIT			

EG1 PREVENTATIVE MAINTENANCE WITH BELT CRADLE KIT			
	<u>PART NO.</u>	<u>DESCRIPTION</u>	<u>QTY</u>
11	8206	Clevis Spring (zinc)	2
13	5516E	Optional: Belt Cradle Kit (includes all hardware)	1
14	1206	Spring, Jaw to Housing (stainless steel)	1
16	HANG-1	3/16 x 1-1/4 Shank Lynch Pin "Hang 1" (9016)	1
17	3006-CP	Cotter Pin, 1/8" x 3/4" (zinc)	6
18	5/32 x 1/2 Roll Pin	Stainless Steel 5/32 x 1/2 Roll Pin	2
	WLG	12oz White Lithium Grease	1
ALL ABOVE ITEMS PART NUMBER: EG1BCPMKIT			

THIS PAGE INTENTIONALLY LEFT BLANK

QUICK-CLAW SAFETY RESTRAINT SYSTEM ASSEMBLY

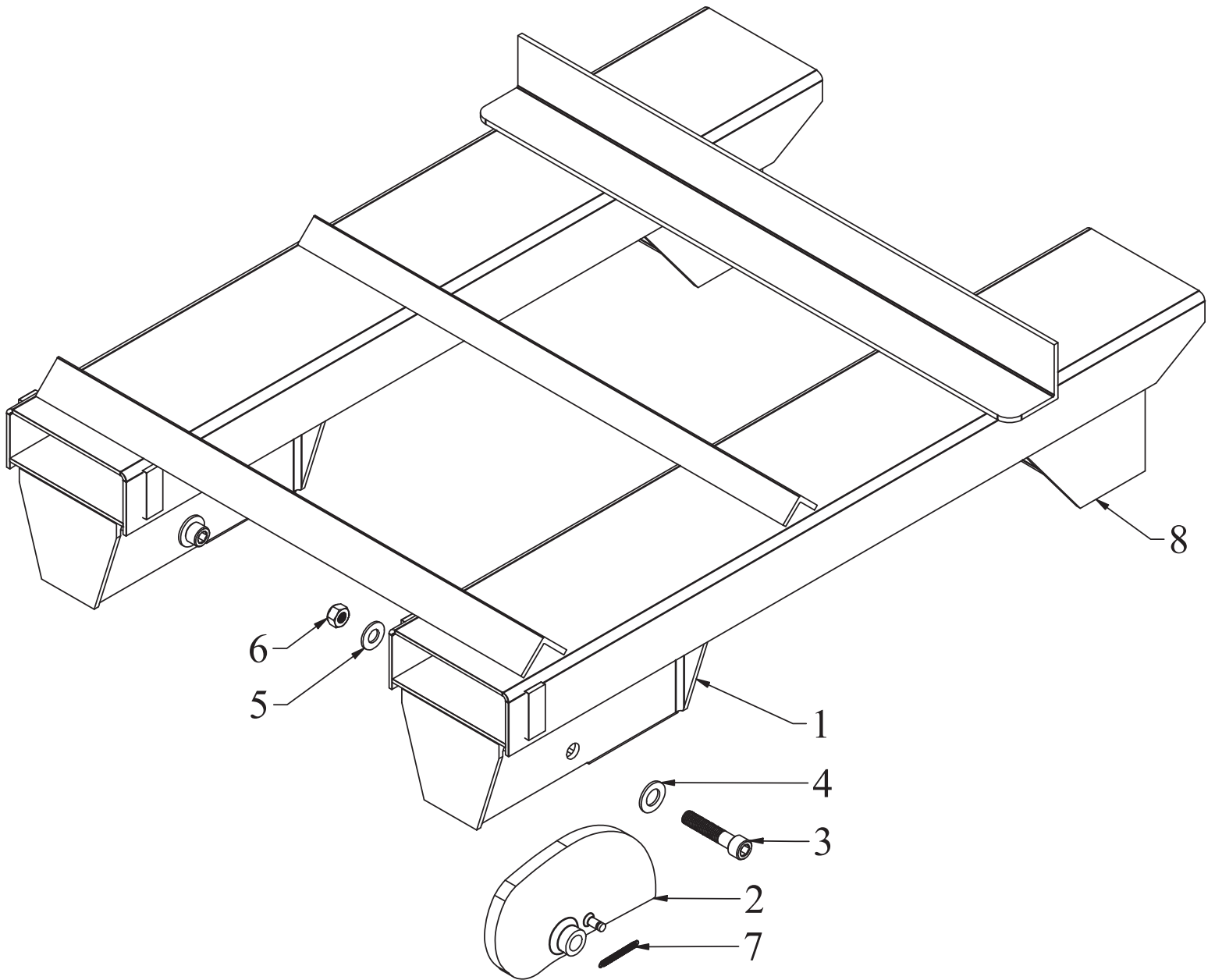

QUICK-CLAW SAFETY RESTRAINT SYSTEM PARTS LIST

<u>ITEM</u>	<u>PART NO.</u>	<u>DESCRIPTION</u>	<u>QTY</u>
1	QCH2.5	Cam Housing	2
2	QCC2.5	Single Cams	2
3	3/4 x 3 SSS	3/4 x 3 Socket Shoulder Screw 5/8-11 Thread (alloy)	2
4	3/4 FW SAE	3/4 Flat Washer SAE (zinc)	2
5	5/8 FW SAE	5/8 Flat Washer SAE (zinc)	2
6	5/8-11 SLN	5/8-11 Stover Lock Nut (zinc)	2
7	KH100799	Spring (zinc)	4
8	QCFPS	Front Fork Pocket Support	2

ASSEMBLY

QCKIT-EG3/4 All parts required for customer installed QUICK-CLAW option for EG3 & EG4 models

NOTE: Installation of these parts require 43" fork pocket length along with welding of front fork pocket supports and cam housings.

SCALE HARDWARE & WIRING FOR ERGO & EAGLE-GRIP STYLE MASTS ASSEMBLY

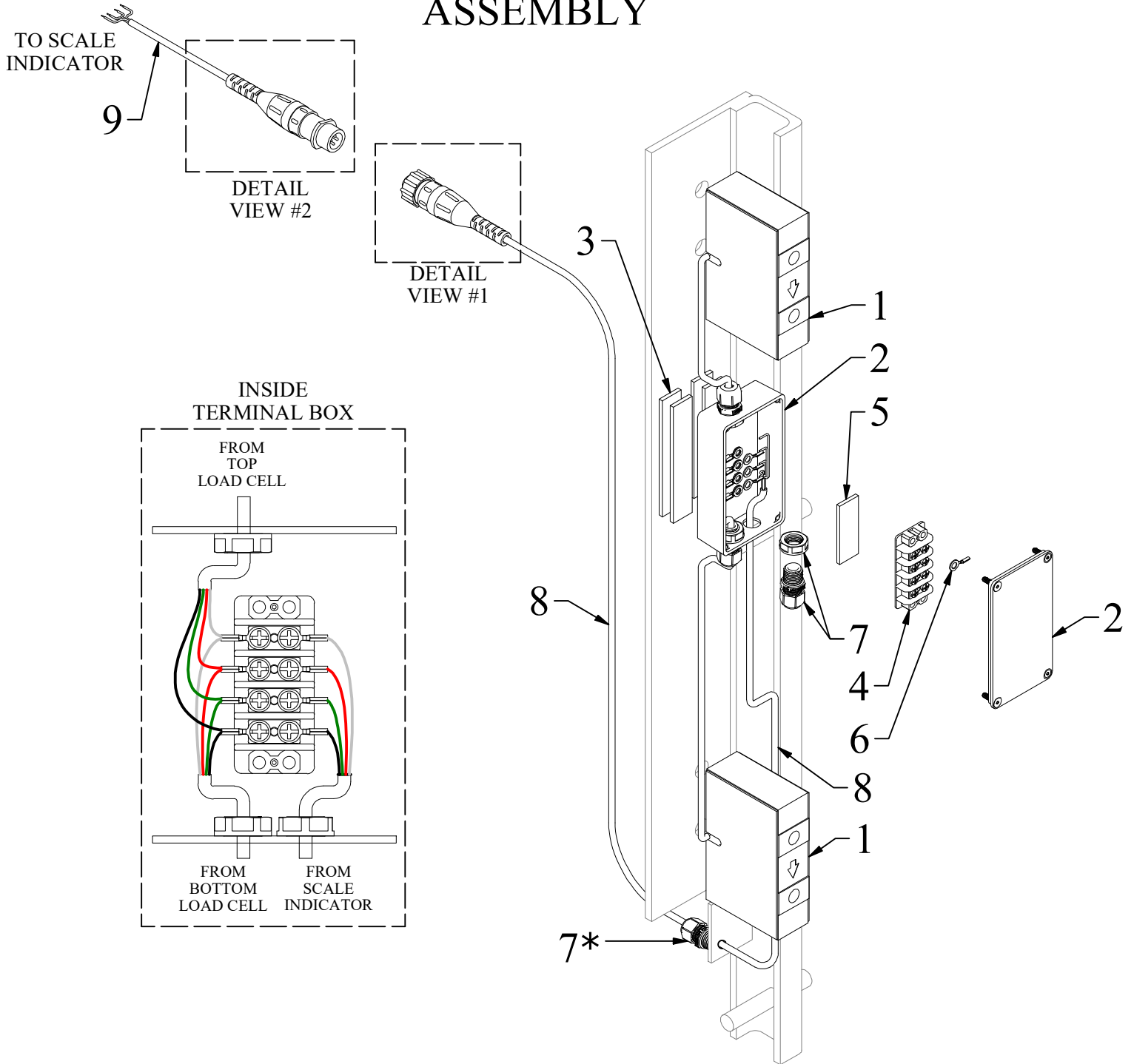

DETAIL VIEW #1 (MACHINE SIDE)

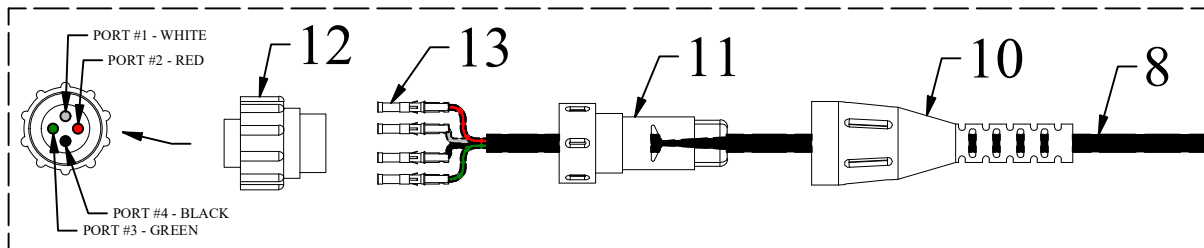

DETAIL VIEW #2 (SCALE SIDE)

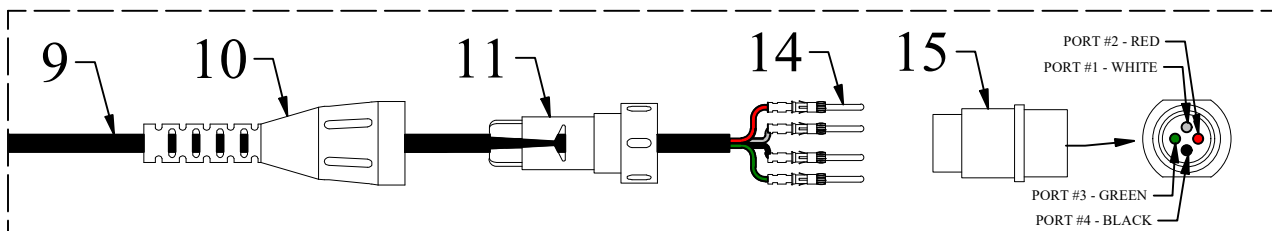

**SCALE HARDWARE & WIRING
FOR ERGO AND EAGLE-GRIP MASTS
PARTS LIST**

<u>ITEM</u>	<u>PART NO.</u>	<u>DESCRIPTION</u>	<u>QTY</u>
1	HM1000	Load Cell with 4' cable	2
2	CU-124	Terminal Box Enclosure	1
3	75315A34-4	Foam Tape, 2 sided adhesive, 3/4" X .125" x 4" length	4
4	7527K64	Terminal Block (Strip) 7/16", 4 circuits	1
5	75315A34-2	Foam Tape, 2 sided adhesive, 3/4" X .125" x 2" length	1
6	3A214	Terminal Eyelet	12
7	ZZHEY3208	Cable Fitting	4
8	3530359	Ergo Scale Cable Assembly (Female End) - 60" Length	1
8	3530360	Eagle-Grip Scale Cable Assembly (Female End) - 30" Length	1
9	3530361	Eagle-Grip/Ergo Scale Cable Assembly (Male End) - 24" Length	1
10	AP2074891	Strain Relief	2
11	AP2074901	Cable Grip	2
12	AP2060601	Connector Plug Size 11-4 (Female)	1
13	AP661054	Terminal Socket	4
14	AP661034	Terminal Pin	4
15	AP2061531	Connector Recp CPC 11-4 (Male)	1

* Modified Strain Relief

Non-Intrinsically Safe Indicators

7000XLM	Doran® 7000XL Non-intrinsically Safe Scale Indicator
SUB0853	Rechargeable Battery, with wire and terminals (2200, 7000, 8000)
2200	Doran® 2200 Non-intrinsically Safe Scale Indicator (Numeric Keypad)
EXOPT319	Battery Option for Non-Intrinsically Safe 2200 Indicator
164582	Rice Lake®482 Indicator w Internal Battery & Charger
164585	Rice Lake®482 Plus Indicator w Internal Battery & Charger
107708	Rice Lake®720i Indicator

Intrinsically Safe Indicators

185288	Rice Lake®882IS Indicator w Battery Pack & Safe Area Charger
185291	Rice Lake®882IS PLUS Indicator w Battery Pack & Safe Area Charger
180831	Rice Lake®882IS Battery
194191	Rice Lake®882IS Battery Charger (IS6V2, 100-240 VAC)
72210052	Mettler Toledo IND226x Indicator ONLY
72258718	Mettler Toledo IND560x Indicator ONLY
64060627	Mettler Toledo EX Indicator Battery (Includes Cable)
64060217	Mettler Toledo Battery Charger (Safe Area, US Plug)

EAGLE-GRIP, EL & MFCR SCALE BRACKET ASSEMBLY

EL & MFCR SWIVEL BRACKET

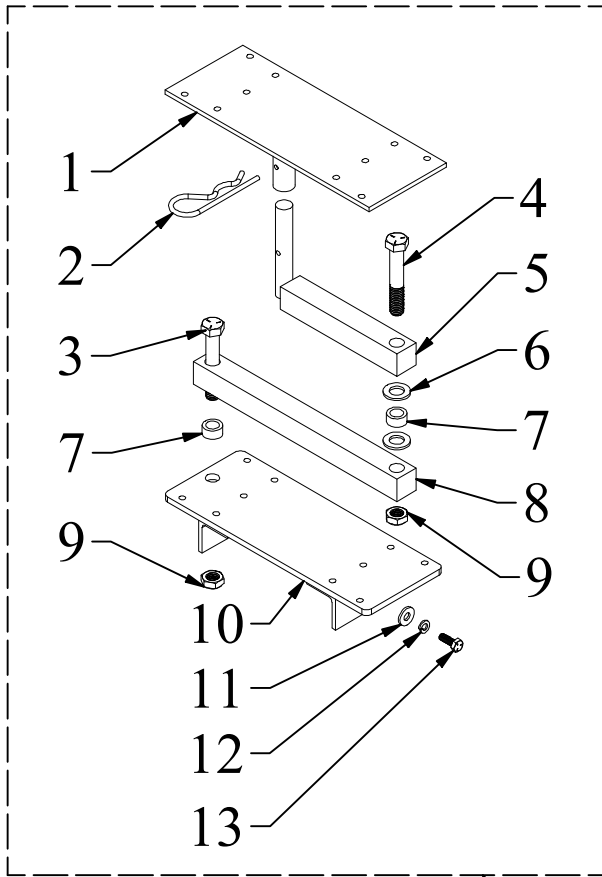

EL ELEVATED RISER

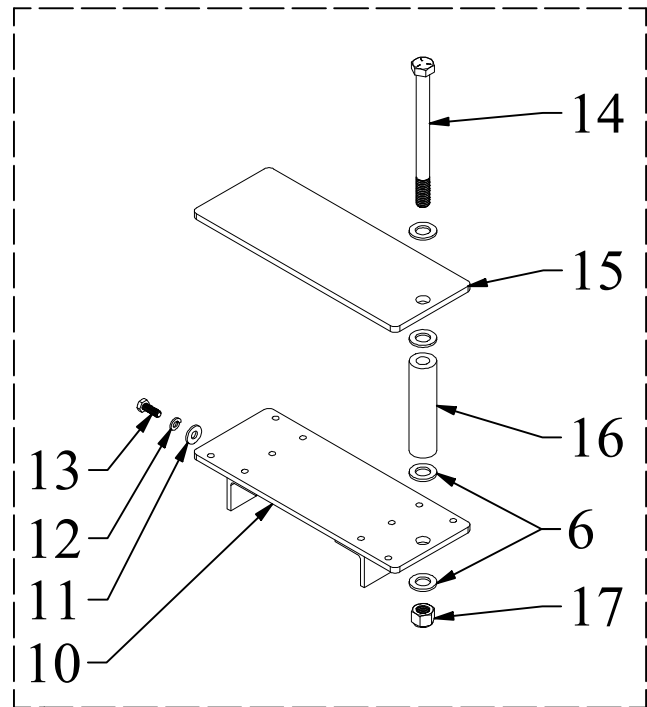

EAGLE-GRIP SWIVEL BRACKET

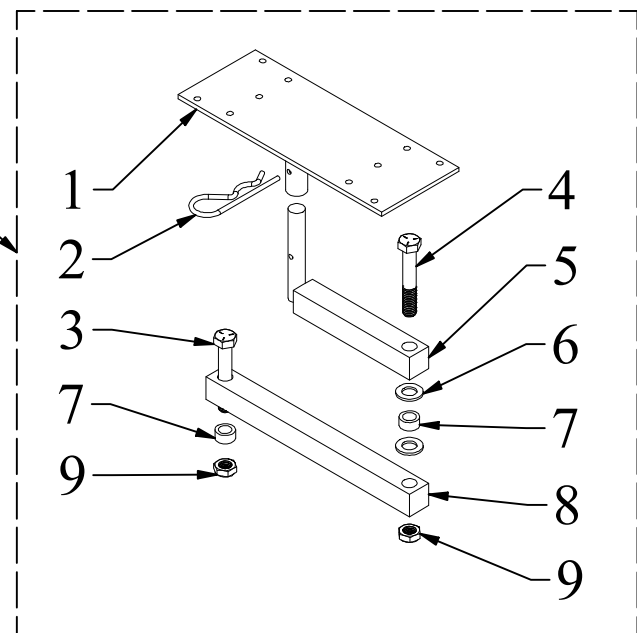

18

19

20

**EAGLE-GRIP, EL & MFCR
SCALE BRACKET
PARTS LIST**

<u>ITEM</u>	<u>PART NO.</u>	<u>DESCRIPTION</u>	<u>QTY</u>
1	3530348	Indicator Mount Bracket With Tube	1
2	98335A094	Zinc-plated steel cotter pin, 7/8"-1 D, 3-3/4 L	2
3	1/2-13 x 2 1/2 HHCS	1/2-13 x 2 1/2 Hex Head Cap Screw Grade 5 (zinc)	2
4	1/2-13 x 3 HHCS	1/2-13 x 3 Hex Head Cap Screw Grade 5 (zinc)	2
5	2580309	Scale Swing Bracket Post Bracket	2
6	1/2 FW	1/2 Flat Washer (zinc)	8
7	10001	Bushing, Housing Yolk Trunion (zinc)	4
8	2580308	Scale Swing Bracket Mid Bracket	2
9	1/2-13 THIN NLN	1/2-13 Nylon Locking Nut (THIN ZINC)	4
10	2580306	Ergo Scale Mount - 1.5" High	2
10	3530396	Ergo Scale Mount - 6.5" High	2
11	1/4 FW SAE	1/4 Flat Washer SAE (zinc)	4
12	1/4 LW	1/4 Lock Washer (zinc)	4
13	1/4-20 x 3/4 HHCS	1/4-20 x 3/4 Hex Head Cap Screw Grade 5 (zinc)	4
14	1/2-13 x 6 HHCS	1/2-13 x 6 Hex Head Cap Screw Grade 5 (zinc)	1
15	3530445	Elevated Scale Plate	1
16	3530446	Elevated Scale Plate Spacer	1
17	1/2-13 NLN	1/2-13 Nylon Locking Nut (zinc)	1
<u>FULL ASSEMBLY</u>			
18	3530447	Ergo Elevated Scale Plate Assembly	1
19	3530404	Ergo Scale Swing Out Bracket 1.5" Assembly	1
19	3530405	Ergo Scale Swing Out Bracket 6.5" Assembly	1
20	3530469	Eagle-Grip Scale Swing Out Bracket Assembly	1